

Roberts RIC. 1

1884

Solid state portable radio receiver

Introduction

An outstanding feature of the Roberts RIC. 1 battery operated radio receiver is the incorporation of an integrated circuit device, a small capsule containing a micro-circuit of eleven transistors, eleven resistors and a diode. The familiar i.f. amplifier has disappeared, and the required degree of selectivity is achieved by means of a crystal filter.

Wavebands covered are m.w. 182-555m (1,648-540kc/s) and l.w. 1,160-2,000m (259-150kc/s), reception is via either the internal ferrite rod aerial assembly or a car-type aerial for which a single point co-axial socket is fitted at the top of the case adjacent to the volume control knob.

Complementary symmetry is employed in the three transistor a.f. amplifier which drives a 7in by 3½in 5Ω elliptical loudspeaker which provides an audio output power in excess of 1W. A normally closed miniature jack located at the top of the case adjacent to the tuning control knob enables an earphone to be connected for personal listening, at the same time muting the internal loudspeaker.

Operating power is supplied by a 9V battery Ever Ready type PP9 or its equivalent.

Voltage analysis

Voltages quoted in the table, col. 3, were obtained from data supplied by the manufacturers and are all positive with respect to battery negative. There was no signal input, the volume control was at minimum and they were measured on a 20,000Ω/V meter.

(Continued overleaf - col. 1)

Resistors

R1	8.2kΩ	B2
R2	150Ω	B1
R3	820Ω	B2
R4	8.2kΩ	B2
R5	390Ω	B2
R6	4.7kΩ	B2
R7	3.3kΩ	B2
R8	27kΩ	B2
R9	390Ω	B2
R10	10kΩ	B2
R11	180Ω	B2
R12	470Ω	B2
R13	12Ω	B2
R14	82kΩ	B2
R15	470Ω	B2
R16	8.2kΩ	B2
R17	390Ω	B2
R18	15kΩ	B2
RV1	22kΩ	A1
RV2	220Ω	B1
RV3	22kΩ	B2

Capacitors

C1	10μF	B2
C2	0.1μF	B1
C3	0.047μF	B2
C4	0.047μF	B2
C5	0.47μF	B2
C6	0.1μF	B2
C7	220pF	B1
C8	0.047μF	B2
C9	0.47μF	B2
C10	0.1μF	B2
C11	2.5μF	B2
C12	0.01μF	A1
C13	0.01μF	B2
C14	400μF	B2

C15	400μF	B2
C16	0.047μF	B2
C17	32μF	B2
C18	0.01μF	B2
C19	640μF	B2
CV1	207pF	B1
CV2	30pF	B1
CV3	80pF	B1
CV4	80pF	B1
CV5	30pF	A1
CV6	110pF	A1

Coils

L1	—	A1
L2	—	B1

L3	—	A1	Miscellaneous
L4	—	B1	
L5	—	A1	
L6	—	B2	
L7	—	B2	
L8	—	B2	
L9	5Ω	†	
D1	BA114	B1	
S1-S7	—	A2	
TAD 100	—	B2	
LP1175	—	B2	

† Loudspeaker.

TAD 100 voltage table

Tag	Volts	Tag	Volts
1	—	8	1.5
2	7.2	9	7.5
3	0.7	10	—
4	1.9	11	2.0
5	1.9	12	—
6	5.2	13	1.3
7	0	14	—

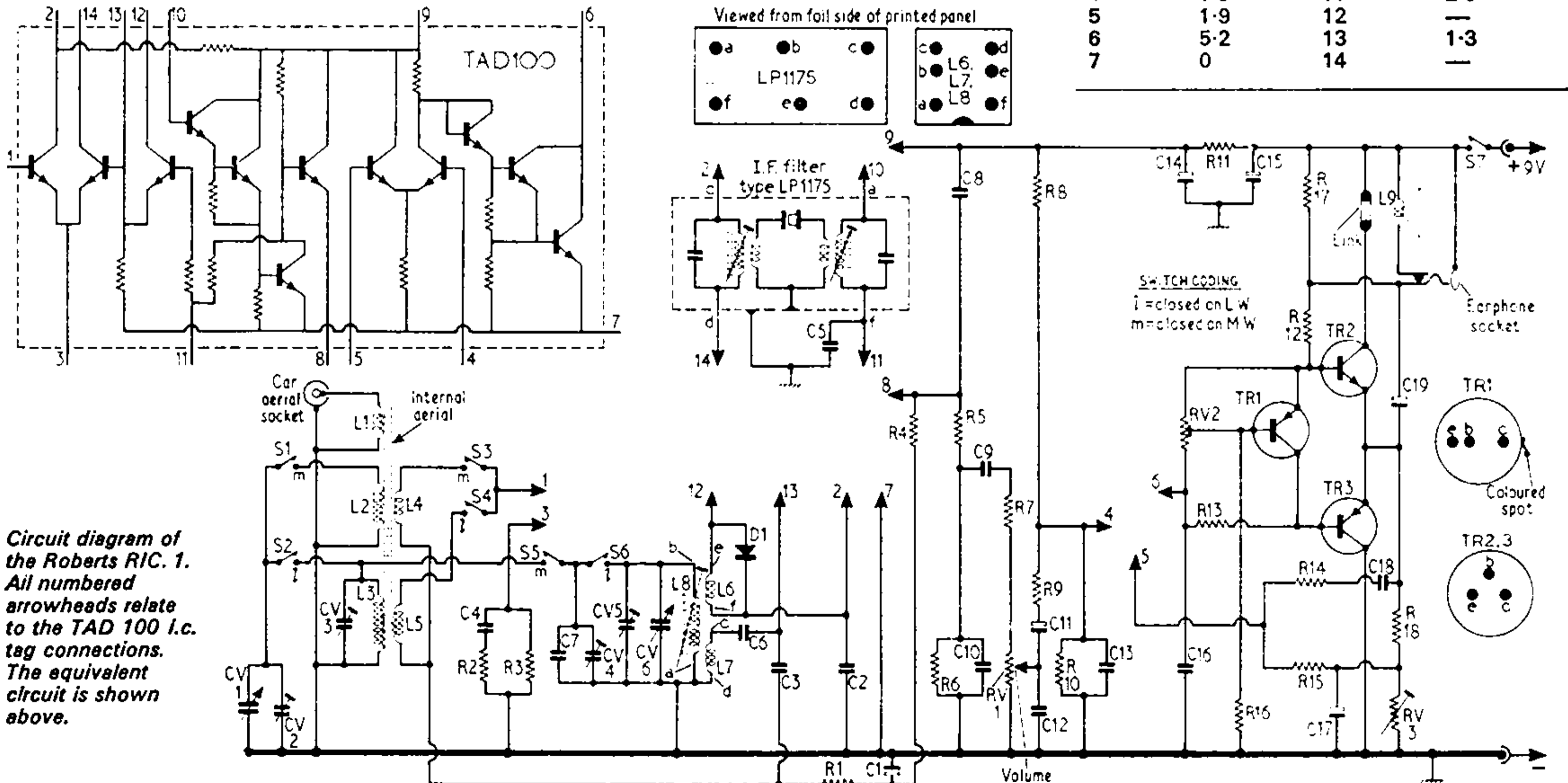

Circuit diagram of the Roberts RIC. 1. All numbered arrowheads relate to the TAD 100 i.c. tag connections. The equivalent circuit is shown above.

1884 Roberts RIC. 1

Continued from overleaf -

For these voltages to apply it is important that battery voltage of 9V measured across **C15** is obtained, the quiescent current being 20mA. The TAD 100 integrated circuit can be checked completely from these d.c. parameters and it should not be suspect unless one or more of these voltages differs considerably from those in the table.

Circuit notes

Mullard TAD 100 silicon integrated circuit used in this receiver incorporates the mixer, oscillator, i.f. amplifier, a.g.c. and audio pre-amplifier stages. Reference to the equivalent circuit diagram shows that where coupled circuits occur within the i.c. they are d.c. couplings. It is because of the absence of a.c. couplings that the d.c. operating voltages are able to be used to determine whether the i.c. is functional or not.

If at any time it should become necessary to replace the i.c. the following precautions should be observed when handling the new i.c. capsule.

The device may be soldered directly into circuits with soldering irons. At bit temperatures below 245deg C the maximum soldering time should be less than ten seconds. Melting point of cored solder (60/40) is 190deg C, and as the temperature of the bit must be about 35-40deg C above this it means that a low power iron, say about 10W, should be used. If the bit temperature is between 245deg C and 400deg C, and this applies to most irons used, then the soldering time should be less than five seconds. Application of the soldering iron should always be below the seating plane (see illustration), and at no time should the device body temperature be allowed to exceed the maximum storage temperature which is 85deg C.

It is also necessary to take care not to bend the lead-out tags above the seating plane.

If filter module Mullard type LP1175 is a bandpass unit containing a ceramic resonator. The nominal frequency of the resonator is 470kc/s. This module establishes the bandwidth

of the i.f. amplifier and its centre frequency. It is important that the transformer cores are not disturbed unless suitable display equipment is available to ensure a symmetrical response curve.

Circuit alignment

Equipment required. - An r.f. signal generator amplitude modulated 30 per cent at 400c/s; an r.f. coupling coil and an audio output meter, impedance 5Ω or, alternatively, an a.c. voltmeter.

Connect the output meter in place of loudspeaker or the voltmeter in parallel with the loudspeaker. Check that with tuning gang at maximum capacitance, the pointer coincides with the low frequency end of the tuning scale. Rotate volume control to maximum, feed all signals in via the r.f. coupling coil, which should be loosely coupled to the ferrite rod aerial assembly, and maintain input signal at a level, such, that the a.g.c. remains inoperative. Alignment calibration marks are indicated on the scale at 1,224m and 1,936m.

1. - Switch receiver to m.w., set tuning to 1,224m and feed in a 1,360kc/s a.m. signal. Adjust **CV5** and **CV2** for maximum output.
2. - Set tuning to 1,936m and feed in a 580kc/s a.m. signal. Adjust **L8** and **L2** for maximum output.
3. - Repeat operations 1 and 2 for optimum results finishing with 1.
4. - Switch receiver to l.w., tune to 1,224m and feed in a 245kc/s a.m. signal. Adjust **CV4** and **CV3** for maximum output.
5. - Tune receiver to 1,936m and feed in a 155kc/s a.m. signal. Adjust **L3** for maximum output.
6. - Repeat operations 4 and 5 for optimum results finishing with 4.

General notes

Dismantling. - Disconnect and remove battery then loosen the three 4BA nuts securing the battery bracket and remove bracket. Unscrew and remove the two 4BA nuts securing the loudspeaker and carefully remove loudspeaker to the extent of its leads. Unscrew and remove two woodscrews at either side of chassis and withdraw the two wooden members. The chassis may now be gently slid out of the case.

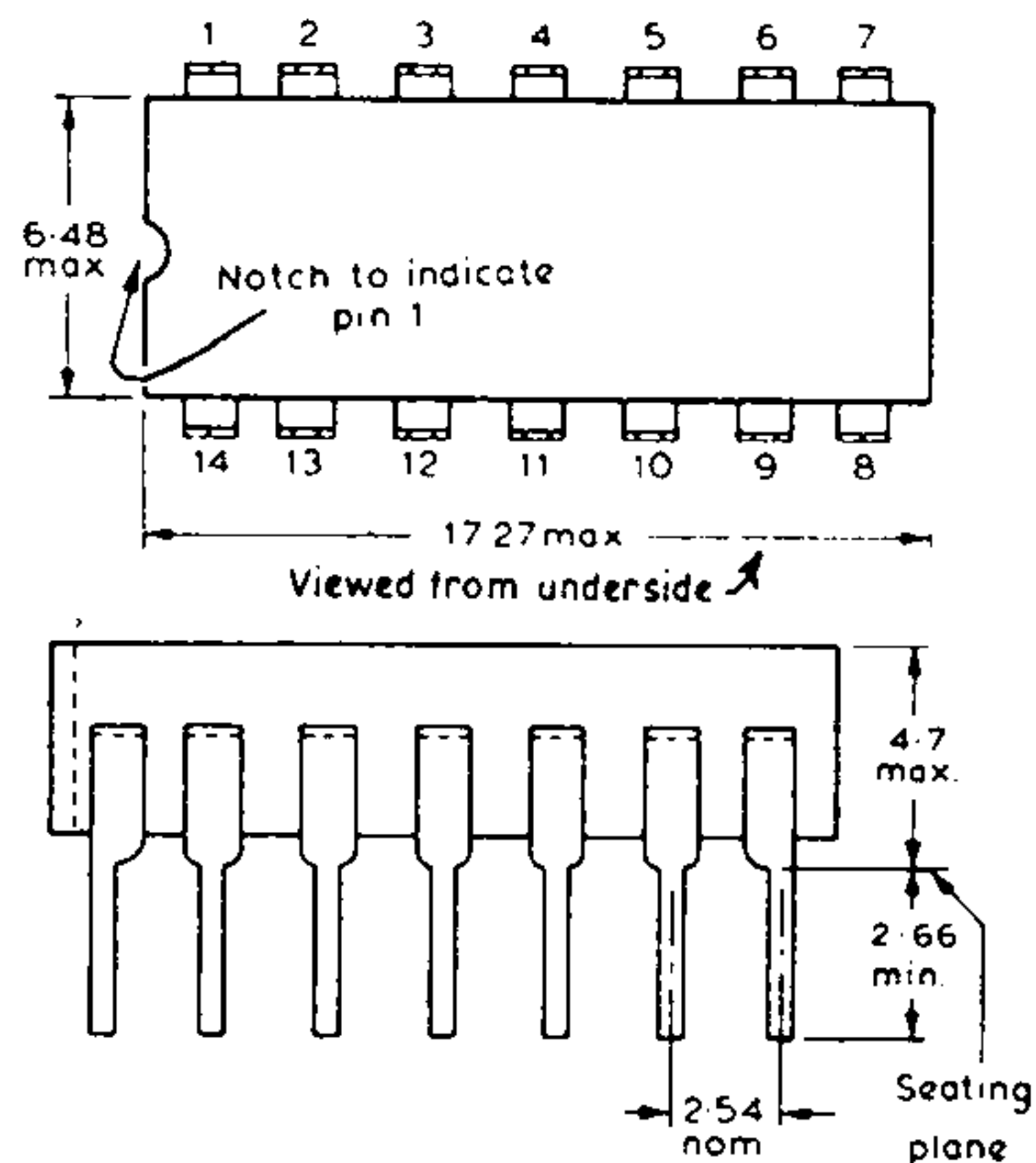

Top and side views of the TAD 100 integrated circuit.

A.f. amplifier adjustments. - The following adjustments are to be carried out with a battery terminal p.d. of 9V measured across **C15**.

Connect a voltmeter between junction **C19/R18** and chassis and, with volume control at minimum, adjust **RV3** to produce 5.2V. Connect a milliammeter in the red flex link on the foil side of printed panel and adjust **RV2** for an output stage quiescent current of 3.5mA at 20deg C. Allow one minute to elapse and recheck this figure. With an oscilloscope observe a sine-wave output and adjust **RV3** for symmetry at onset of clipping.

Manufacturer's service department

Roberts Radio Company Limited,
Molesey Avenue,
West Molesey,
Surrey.

(Telephone: MOlesey 7474.)

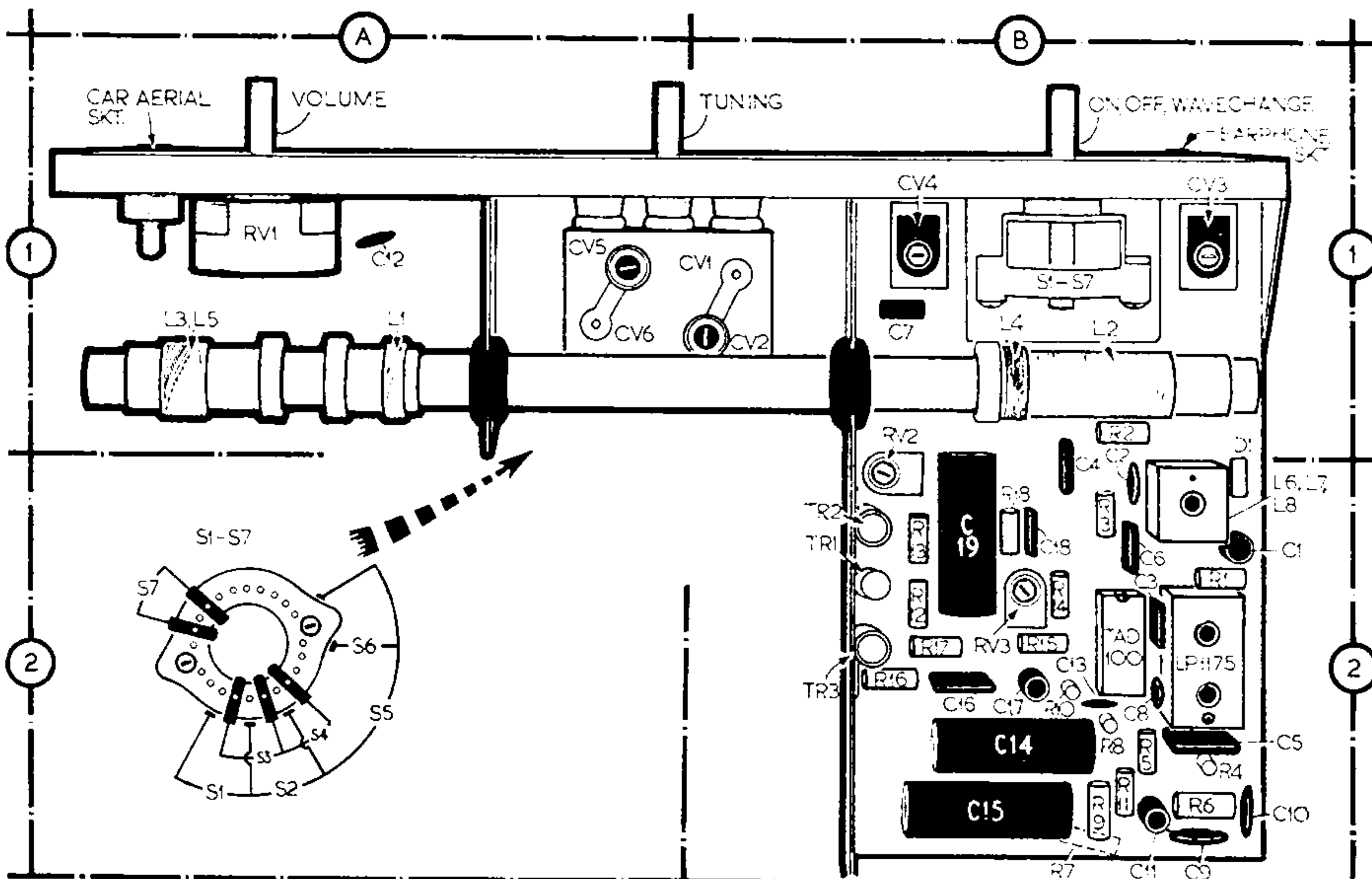

Rear view illustration of the component side of chassis when removed from case. Details of the waveband switch assembly are shown in location A2.