

# PHILIPS

# Type 2811.

ONE always rather envies the designers of radio-gramophones, who are generally less hampered by considerations of cost than those who deal with the ordinary type of receiver. A combined set is almost certain to be fairly expensive in any case, and in consequence non-essential but nevertheless desirable refinements are more likely to escape the axe of economy.

Although the Philips Model 2811 radio-gramophone is not particularly costly, especially when one takes into account the fact that nothing has been skimped in its circuit arrangement or construction, it embodies details which are not usually to be found in similar instruments.

With regard to the circuit, the receiver unit fitted is practically the well-known Philips set, type 2511, but with a greater power output. Two H.F. amplifying stages are used, and the valves are coupled by the tuned anode method, matters being so arranged that the frames and rotors of the three-member ganged tuning condenser assembly are earthed. Wave-changing is effected by the usual expedient of inserting series-loading coils, which are shunted by short-circuiting switches.

Grid detection is employed, and a transformer is used to couple the rectifier to a special type of directly-heated super-power pentode (PM24C), which gives an exceptionally large undistorted power output, actually in the neighbourhood of  $3\frac{1}{2}$  watts. In conjunction with the moving-coil loud speaker which is included, volume is not only sufficient for domestic purposes, but is even enough to fill a small hall, should it be necessary to do so.

Bias is obtained by picking up suitable negative voltages from a potentiometer in the H.T. negative lead, and, on the "radio" side, volume is controlled by changing the negative grid voltage of the first H.F. valve. Another potentiometer (not shown in the accompanying circuit diagram) is provided for regulating the intensity of gramophone reproduction.

It will be observed that decoupling is unusually complete, as a double filter arrangement is included in the first grid circuit and in series with the detector anode. Valve rectification is provided for the H.T. supply, and there is a separate rectifier for the loud-speaker field.



A High-grade Radio-Gramophone with Large Output and Many Refinements.

A Philips type 506K valve is used for this purpose.

Another feature which will be widely appreciated is a variable tone control, by means of which high frequencies may be attenuated or suppressed. The primary purpose of this filter is to reduce needle scratch, but it will mitigate interference due to heterodyning carrier waves, and, on occasion, to neighbouring power circuits.

A two-unit system of construction for the receiver has been adopted, and the H.F.-detector and L.F. chassis are both mounted on the floor of the cabinet. As all control knobs are concentrated around the turntable, it becomes necessary to operate the variable condensers from a distance; the difficulty has been overcome in an ingenious manner by fitting a spring-tensioned metal belt drive, which acts without back

lash and in a positive manner. Similarly, a metal link is connected between the control panel and the master switch of the receiver.

In order that internal adjustments may be carried out without risk of shock, a safety switch is fitted in the back lid in such a way that the mains supply lead is automatically broken when this lid is removed.

The turntable is driven by an electric motor, for which, by the way, a special oiler is provided. There is an automatic stop, so that the armature comes to rest as soon as a record has been played.

It will be observed that the output transformer is tapped, in order that external loud speakers of different impedances may be matched to the output valve. Sockets are provided for these connections.

What strikes one as a particularly useful fitting is a pneumatic buffer for the lid, which, in consequence, need not be closed with any particular care after it has been opened to obtain access to the controls or to change a record.

Both internally and externally, the instrument is extremely well made, and, in particular, the construction and finish of the polished

walnut cabinet are beyond criticism. There is an internal space for records, and albums are supplied. The makers are Philips Lamps, Ltd., Philips House, 145, Charing Cross Road, London, W.C.2, and the price is 80 guineas complete.

### SPECIFICATION.

**CIRCUIT:** Two H.F. stages with tuned anode couplings; grid detector, coupled by transformer to super-power output pentode.

**CONTROLS:** Combined wave-range, radio-gramophone, and on-off switch, single-knob tuning, gramophone volume control, radio volume control, scratch filter (or tone control).

**GENERAL:** For operation on A.C. mains with inside, outside, or frame aerial.

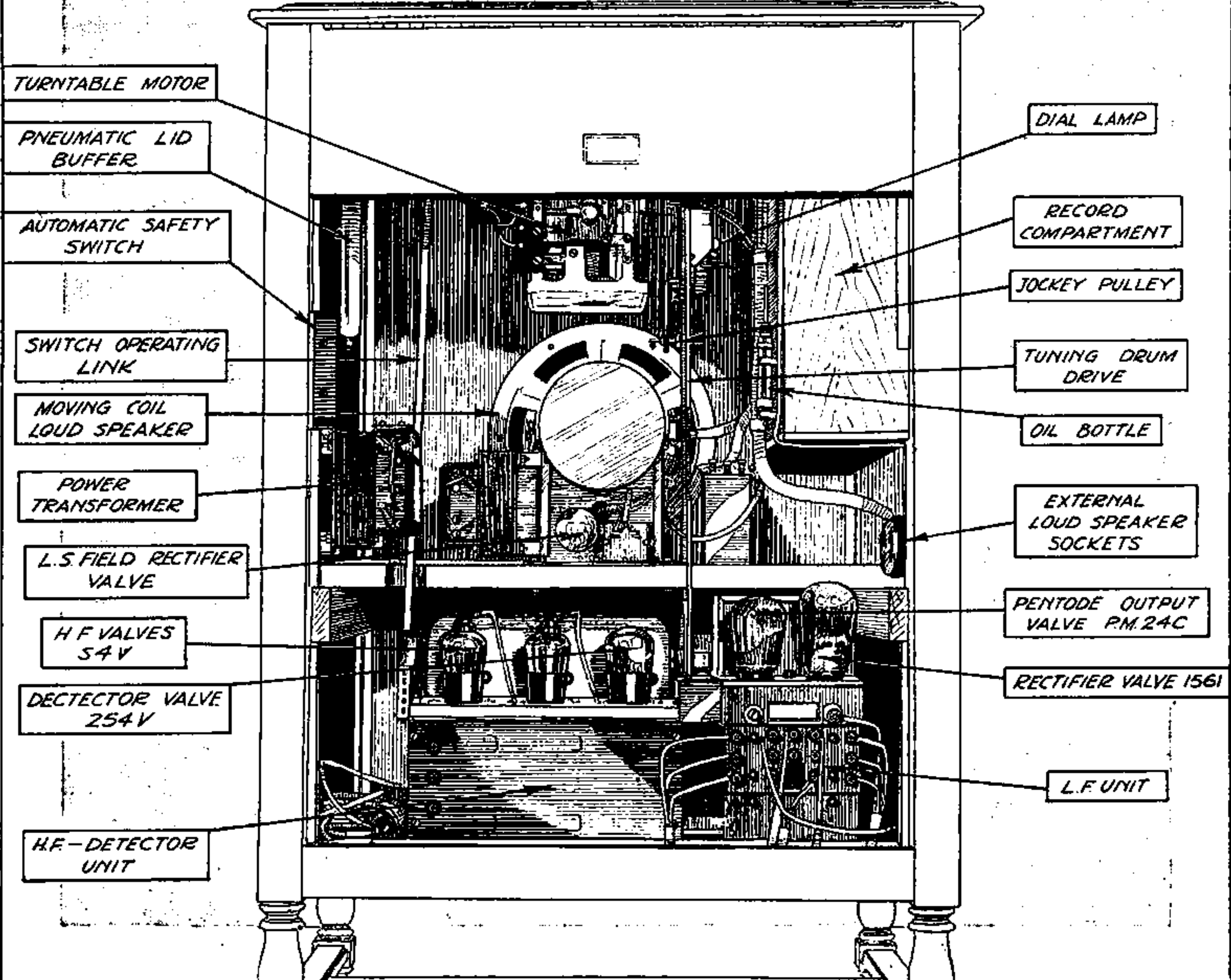
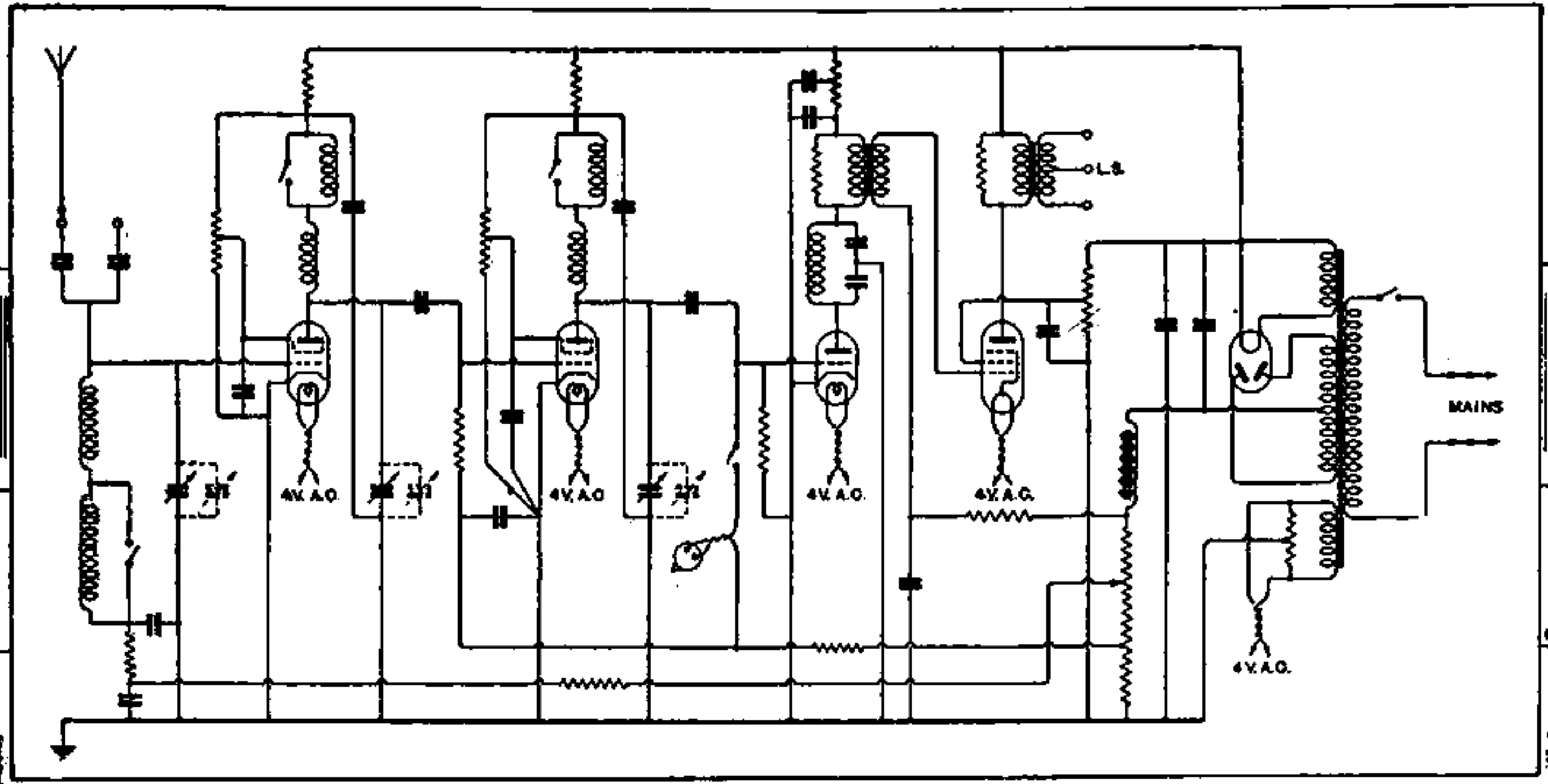

Circuit details and interior arrangement of the Philips radio-gramophone.