

Ned. Ver. v. Historie v/d Radio



MURPHY A170

Covering the Welwyn and Dublin versions and including the A170R Autoradiogram

CIRCUIT DESCRIPTION

ANTI-SHOCK and anti-fire devices form part of the design of the Murphy A170 receiver, a 4-valve (plus rectifier) 3-band superhet designed to operate from A.C. mains of 200-250 V, 50-100 c/s. The waveband ranges are 16-52 m, 190-560 m and 1,000-2,050 m.

The safety precautions against shock include double-pole mains switching, a double-wound mains transformer and an earth wire in the mains lead while against fire risk there is a heat-operated fuse in the mains input circuit and another in the H.T. circuit to prevent overheating.

One version of the A170 was made in Welwyn, and another, containing small differences, in Dublin. In Dublin only a radiogram version, the A170R, was also produced.

Release dates and original prices. Welwyn model: April 1950, £23 14s 7d plus purchase tax. Dublin models: A170, September 1950, £34 15s; A170R, October 1950, £61 0s.

Aerial input via I.F. filter **L1, C1** and coupling coils **L2** (S.W.), **L3** (M.W.) or **L4** (L.W.) to single tuned circuits **L5, C39** (S.W.), **L6, C39** (M.W.) or **L7, C39** (L.W.) which precede triode heptode valve (**V1, Mazda 6C9**), operating as frequency changer with internal coupling.

Triode oscillator anode coils **L10** (S.W.), **L12** (M.W.) and **L11** (L.W.) are tuned by **C43, L11** and **L12** being connected in series for L.W. operation. Parallel trimming by **C40** (S.W.), **C12, C42** (M.W.) and **C11, C41** (L.W.); series tracking by **C10** (M.W.) and **C9, C10** (L.W.). Inductive reaction coupling from grid by **L8** (S.W.) and **L9** (M.W. and L.W.) with addition coupling across the common impedance of tracker **C10**.

The waveband switching operations are rather unusual, and because it helps to make the circuit less complicated the L.W. circuit is drawn above the M.W. circuit in our diagram. **S10** closes on

M.W. and L.W. to connect the reaction coupling circuit **L9, C10**, but **S14** closes only on S.W., shunting these two components by **C11, C41**. **S13** closes for L.W., leaving **L11** and **L12** in series, but for M.W. operation **S12** and **S13** close, short-circuiting **L11** via **R5**.

Second valve (**V2, Mazda 6F15**) is a variable-mu R.F. pentode operating as intermediate frequency amplifier with tuned transformer couplings **C5, L13, L14, C6** and **C17, L15, L16, L17, C18**.

Intermediate frequency 465 kc/s.

Diode signal detector is part of double diode triode valve (**V3, Mazda 6LD20**). Audio frequency component in rectified output is developed across diode load resistors **R12, R13** and passed via **C22** and volume control **R14** to control grid of triode section, which acts as A.F. amplifier. D.C. potential developed across **R12, R13** is fed via decoupling circuit **R11, C25** to control grid of the cathode ray tuning indicator (**T.I., Mazda**

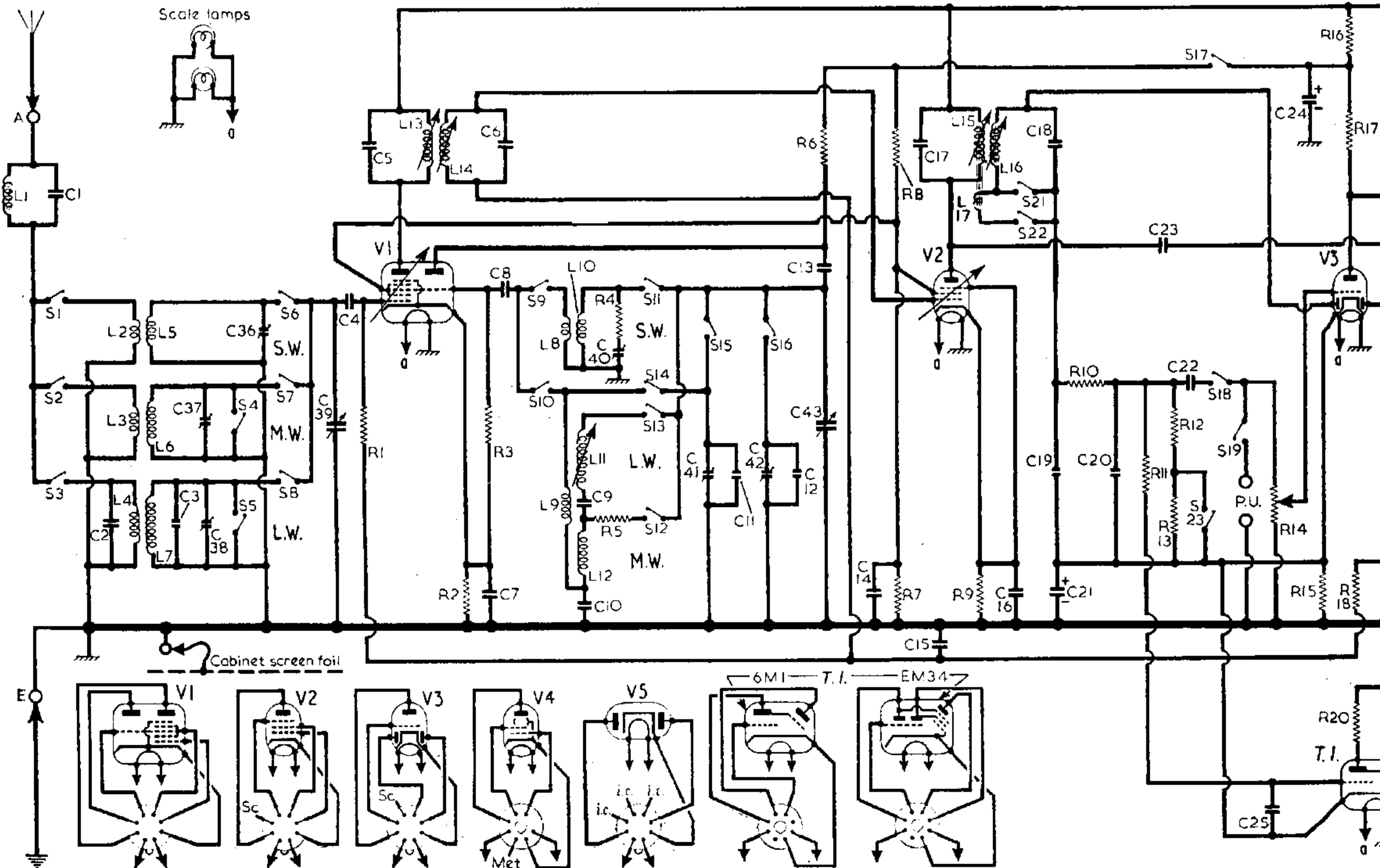

Circuit diagram of the Murphy A170 receiver, as produced at Welwyn. Another version, produced at Dublin, contains two small diodes which are explained overleaf under "Modifications". The temperature fuse in the mains transformer circuit melts if the transformer over-

6M1), its potential rising negatively as the incoming signal strength increases.

Second diode of V3 is fed via C23 from V2 anode, and the resulting D.C. potential developed across load resistor R19 is fed back via decoupling circuit as bias to F.C. and I.F. valves, giving automatic gain control.

Provision is made for the connection of a gramophone pick-up across R14 via S19, which closes in the gram position of the waveband switch. S17 and S18 open in this position to mute the radio circuits.

Resistance-capacitance coupling via R17, C26 and R22 between V3 anode and control grid of beam pentode output valve (V4, Mazda 6P25). Four-position tone control S21-S26 varies the high frequency response of the A.F. stage by shunting C27, C28 and C29 across V4 grid circuit, and widens the bandwidth of the second I.F. transformer by increasing the coupling between L15 and L16 via L17.

S24 is part of the tone control switch unit, and S20 is part of the waveband switch unit, the latter closing only on gram. On radio, therefore, C27 does not come into circuit in position 3 of the tone control. The purpose of S23 is to reduce the diode load in the high fidelity setting (position 4) with the dual advantage of preventing an overall rise in gain when L17 is switched into circuit and increasing the A.C./D.C. ratio of the diode load to

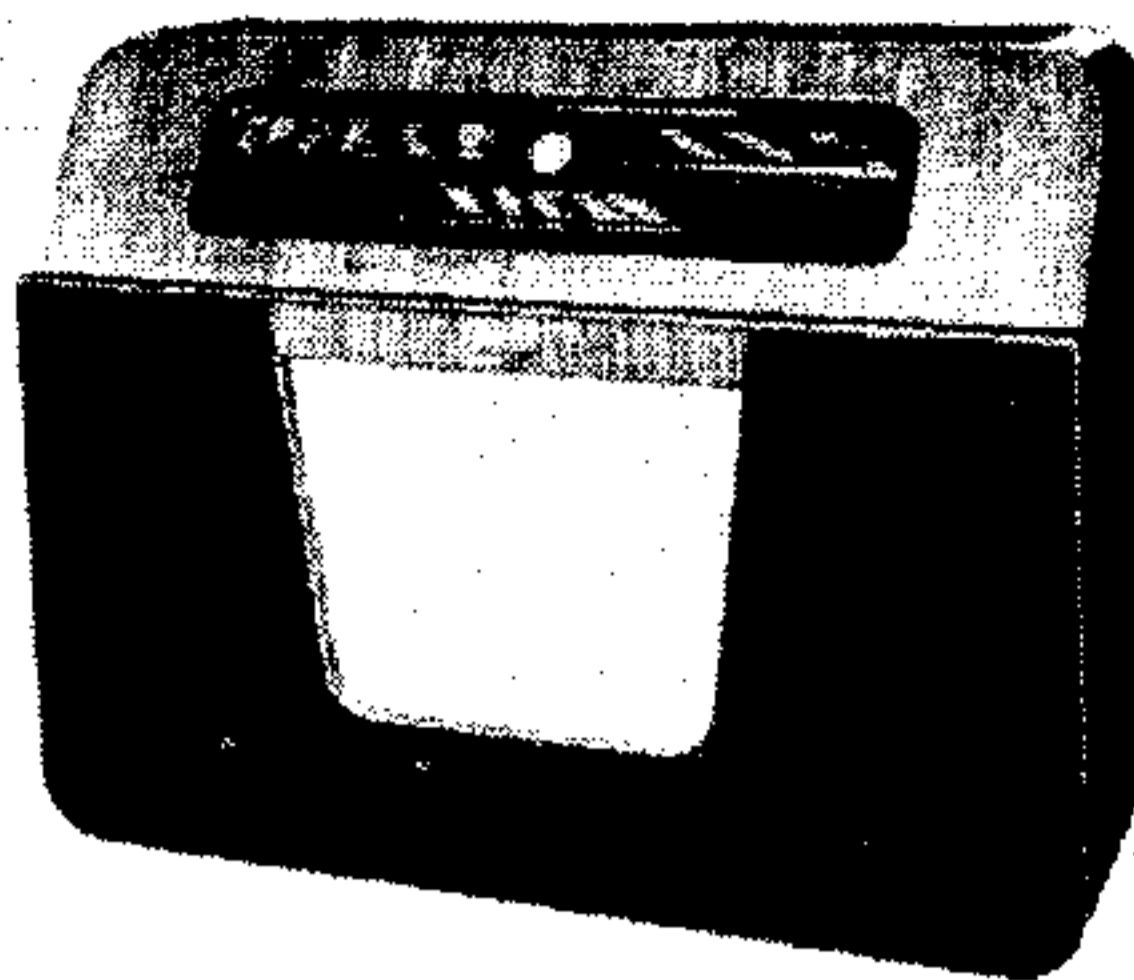

The appearance of the Murphy A170. The controls are in a row along the bottom.

give improved reproduction at high modulation levels.

Fixed tone correction is provided permanently by R23, C32 in the anode circuit of V4.

L18, C31 form a whistle filter, tuned to 9 kc/s. Provision is made for the connection of a low impedance external speaker across T1 secondary by sockets in the internal speaker plugs.

H.T. current is supplied by I.H.C. full-wave rectifying valve (V5, Mazda UU9). Smoothing by L20 and electrolytic capacitors C34, C35. The temperature fuse consists of a spring contact which is held by a low melting-point alloy to a copper bar embedded in the mains transformer T2 near the primary winding. One side of the mains is connected to the transformer primary through the temperature fuse, and if the transformer becomes overheated owing to a component breakdown, the copper bar conducts the heat to the fusible alloy and melts it, releasing the spring contact and breaking the input circuit.

A second safety measure is provided in the form of a special H.T. feed resistor to parts of the circuit too remote or too small to affect the temperature fuse. This is R16 which, if it overheats, becomes open-circuited and isolates that part of the circuit that contains the fault.

COMPONENTS AND VALUES

| RESISTORS | | Values | Locations |
|-----------|-------------------------|--------|-----------|
| R1 | V1 C.G. ... | 470kΩ | G3 |
| R2 | V1 G.B. ... | 220Ω | F3 |
| R3 | V1 osc. C.G. ... | 22kΩ | F4 |
| R4 | } Osc. stabilizers ... | 56Ω | G4 |
| R5 | | 15Ω | G4 |
| R6 | Osc. anode feed ... | 27kΩ | F4 |
| R7 | } S.G. pot. divider ... | 27kΩ | F4 |
| R8 | | 12kΩ | F4 |
| R9 | V2 G.B. ... | 330Ω | F4 |
| R10 | I.F. stopper ... | 150kΩ | E4 |
| R11 | T.I. decoupling ... | 2.2MΩ | F4 |
| R12 | } Signal diode load ... | 150kΩ | E3 |
| R13 | | 330kΩ | D3 |
| R14 | Volume control ... | 1MΩ | E3 |
| R15 | V3 G.B. ... | 1.5kΩ | E4 |
| R16 | H.T. feed* ... | 2.2kΩ | C2 |
| R17 | V3 anode load ... | 47kΩ | E4 |
| R18 | A.G.C. decoupling ... | 1MΩ | E4 |
| R19 | A.G.C. diode load ... | 1MΩ | E4 |
| R20 | T.I. anode load ... | 1MΩ | B1 |
| R21 | } V4 C.G. ... | 100kΩ | E4 |
| R22 | | 470kΩ | E4 |
| R23 | Tone corrector ... | 6.8kΩ | D4 |
| R24 | V4 anode stopper ... | 47Ω | E4 |
| R25 | V4 G.B. ... | 180Ω | E4 |

*Special type: see "Safety Devices" under "General Notes."

CAPACITORS

| | | Values | Locations |
|------|-------------------------|------------|-----------|
| C1 | I.F. rejector tune ... | 470pF | A1 |
| C2 | L.W. aerial shunt ... | 470pF | F3 |
| C3 | L.W. aerial trim ... | 47pF | F3 |
| C4 | V1 C.G. ... | 470pF | G3 |
| C5 | } 1st I.F. trans. ... | 150pF | B2 |
| C6 | | tuning ... | 150pF |
| C7 | V1 cath. by-pass ... | 0.05μF | F3 |
| C8 | V1 osc. C.G. ... | 100pF | G4 |
| C9 | } Osc. trackers ... | 180pF | G4 |
| C10 | | | 620pF |
| C11 | } Osc. trimmers ... | 92pF | G4 |
| C12 | | | 10pF |
| C13 | Osc. anode coup. ... | 150pF | G4 |
| C14 | S.G. decoupling ... | 0.1μF | F3 |
| C15 | A.G.C. decoupling ... | 0.05μF | F3 |
| C16 | V2 Cath. by-pass ... | 0.05μF | F4 |
| C17 | } 2nd I.F. trans. ... | 150pF | B2 |
| C18 | | tuning ... | 150pF |
| C19 | } I.F. by-passes ... | 47pF | E4 |
| C20 | | | 82pF |
| C21* | V3 cath. by-pass ... | 50μF | C1 |
| C22 | A.F. coupling ... | 0.01μF | G3 |
| C23 | A.G.C. coupling ... | 47pF | E4 |
| C24* | H.T. decoupling ... | 16μF | E3 |
| C25 | T.I. decoupling ... | 0.05μF | B1 |
| C26 | A.F. coupling ... | 0.01μF | E4 |
| C27 | } Part tone control ... | 390pF | D3 |
| C28 | | | 0.001μF |
| C29 | | 0.0022μF | D3 |
| C30 | I.F. by-pass ... | 100pF | E4 |
| C31 | Part whistle filter ... | 820pF | B1 |
| C32 | Tone corrector ... | 0.02μF | E4 |
| C33* | V4 cath. by-pass ... | 50μF | C1 |
| C34* | } H.T. smoothing ... | 16μF | D3 |
| C35* | | | 32μF |
| C36† | S.W. aerial trim. ... | 35pF | F3 |
| C37† | M.W. aerial trim. ... | 35pF | G3 |
| C38† | L.W. aerial trim. ... | 35pF | F3 |
| C39† | Aerial tuning ... | 580pF | A1 |
| C40† | S.W. osc. trim. ... | 35pF | G4 |
| C41† | L.W. osc. trim. ... | 35pF | G4 |
| C42† | M.W. osc. trim. ... | 35pF | G4 |
| C43† | Oscillator tuning ... | 580pF | A2 |

* Electrolytic. † Variable. ‡ Pre-set.

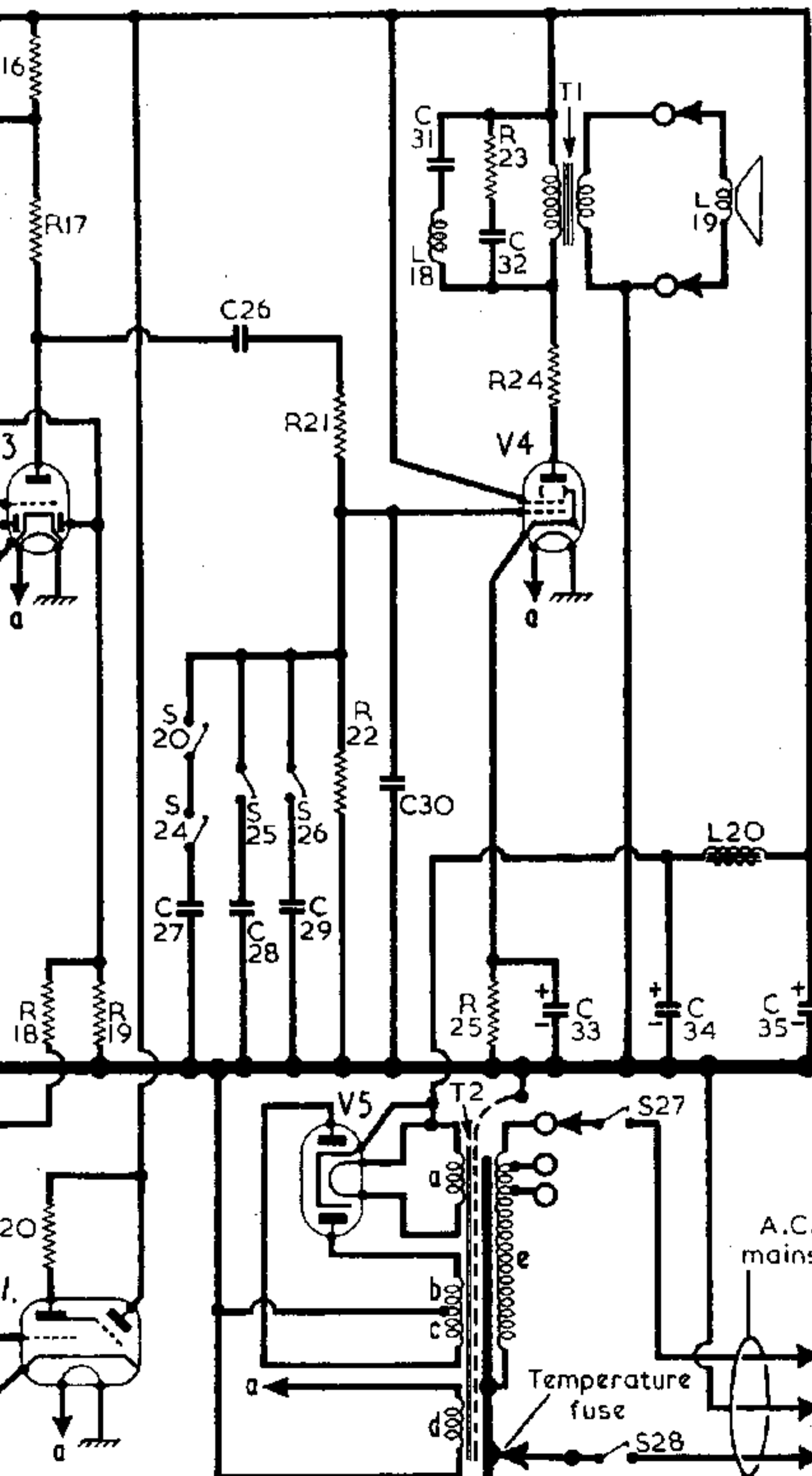

all differences in the aerial circuit and mains lead, after overheats, and open-circuits the mains supply.

OTHER COMPONENTS

| | | Approx. Values (ohms) | Locations |
|----------|------------------------------|-----------------------|-----------|
| L1 | I.F. rejector ... | 3.0 | A1 |
| L2 | } Aerial coupling coils | — | A1 |
| L3 | | 1.2 | A2 |
| L4 | | 22.0 | A2 |
| L5 | } Aerial tuning coils | — | A1 |
| L6 | | 4.0 | A2 |
| L7 | 22.5 | A2 | |
| L8 | } Osc. reaction coils | — | G4 |
| L9 | | 1.0 | G4 |
| L10 | | — | G4 |
| L11 | } Osc. tuning coils | 5.0 | G4 |
| L12 | | 2.2 | G4 |
| L13 | } 1st I.F. trans. { Pri. ... | 6.2 | B2 |
| L14 | | Sec. ... | 6.2 |
| L15 | } 2nd I.F. trans. { Pri. ... | 6.2 | B2 |
| L16 | | Sec. ... | 6.2 |
| L17 | Coup. ... | — | B2 |
| L18 | Whistle filter ... | 305.0 | B2 |
| L19 | Speech coil ... | 2.4 | — |
| L20 | H.T. smoothing ... | 267.0 | E3 |
| T1 | } O.P. trans. { Pri. ... | 310.0 | B2 |
| | | Sec. ... | — |
| T2 | } Mains trans. { a... 157.0 | 167.0 | C2 |
| | | b... 167.0 | |
| | | c... 167.0 | |
| | | d... 36.0 | |
| | | e total | 36.0 |
| S1-S20 | Waveband switches | — | G3 |
| S21-S26 | Tone switches | — | D3 |
| S27, S28 | Mains switches | — | D3 |

If the component numbers given in the accompanying tables are used when ordering replacement parts, dealers are advised to mention the fact on the order, as these numbers may differ from those used in the manufacturers' diagram.

VALVE ANALYSIS

Valve voltages and currents given in the table below are those measured on our receiver when it was operating from A.C. mains of 230 V. The receiver was tuned to the highest wavelength end of M.W. and the volume control turned to maximum, but there was no signal input.

Voltage readings were measured with an Avo Electronic TestMeter, and as this instrument draws no appreciable current, allowance must be made for the current drawn by other types. Chassis was the negative connection. The target voltage on the cathode ray tuning indicator was 250 V, and that on the triode anode 22 V.

| Valves | Anode | | Screen | | Cath. |
|--------------|------------|------------|--------|-----|-------|
| | V | mA | V | mA | V |
| V1 6C9 ... | 245 74 | 2.2 5.0 | 100 | 4.0 | 2.5 |
| | Oscillator | | | | |
| V2 6F15 ... | 245 | 6.0 | 100 | 1.8 | 2.4 |
| V3 6LD20 ... | 134 | 1.5 | — | — | 4.5 |
| V4 6P25 ... | 230 | 38.0 | 245 | 7.7 | 7.8 |
| V5 UU9 ... | 230† | — | — | — | 260.0 |

† Each anode A.C.

CIRCUIT ALIGNMENT

The chassis should be removed from its cabinet for the following alignment adjustments. Turn volume control to maximum and set the tone control to position 1.

I.F. Stages.—When adjusting the I.F. transformers a damping unit consisting of a 10 kΩ resistor in series with an 0.01 μF capacitor should be connected via the shortest possible leads across one winding while the core of the other is adjusted. Connect output of signal generator, via an 0.01 μF capacitor in the "live" lead, to control grid (pin 6) of V2 and chassis.

Tune receiver to highest wavelength end of M.W., feed in a 465 kc/s (645.16 m) signal and adjust the cores of L16 (B2) and L15 (E4) for maximum output. Transfer signal generator leads with isolating capacitor to control grid (pin 6) of V1 and chassis, and adjust the cores of L14 (B2) and L13 (F4) for maximum output.

R.F. and Oscillator Stages.—As the tuning scale remains fixed in the cabinet when the chassis is withdrawn, reference is made during alignment to the substitute tuning scale printed on the front of the drive drum. Readings on this scale are taken against the "V" notch in the metal cursor mounted below the drum. The substitute scale readings are given in brackets after each calibration point in the following alignment and refer to the moulded drive drum only. For receivers using a metal drive drum, 60 must be added to each substitute scale reading quoted. Check that with the gang at maximum capacitance, the notch in the metal cursor coincides with "0" on the moulded drive drum scale, or "60" on the metal drive drum scale. Transfer signal generator leads, with isolating capacitor, to A and E sockets.

L.W.—Switch receiver to L.W., tune to 1,900 m (37.5 on substitute scale), feed in a 1,900 m (158 kc/s) signal and adjust the core of L11 (A2) for maximum output. Tune receiver to 1,000 m (167.5 on scale), feed in a 1,000 m (300 kc/s)

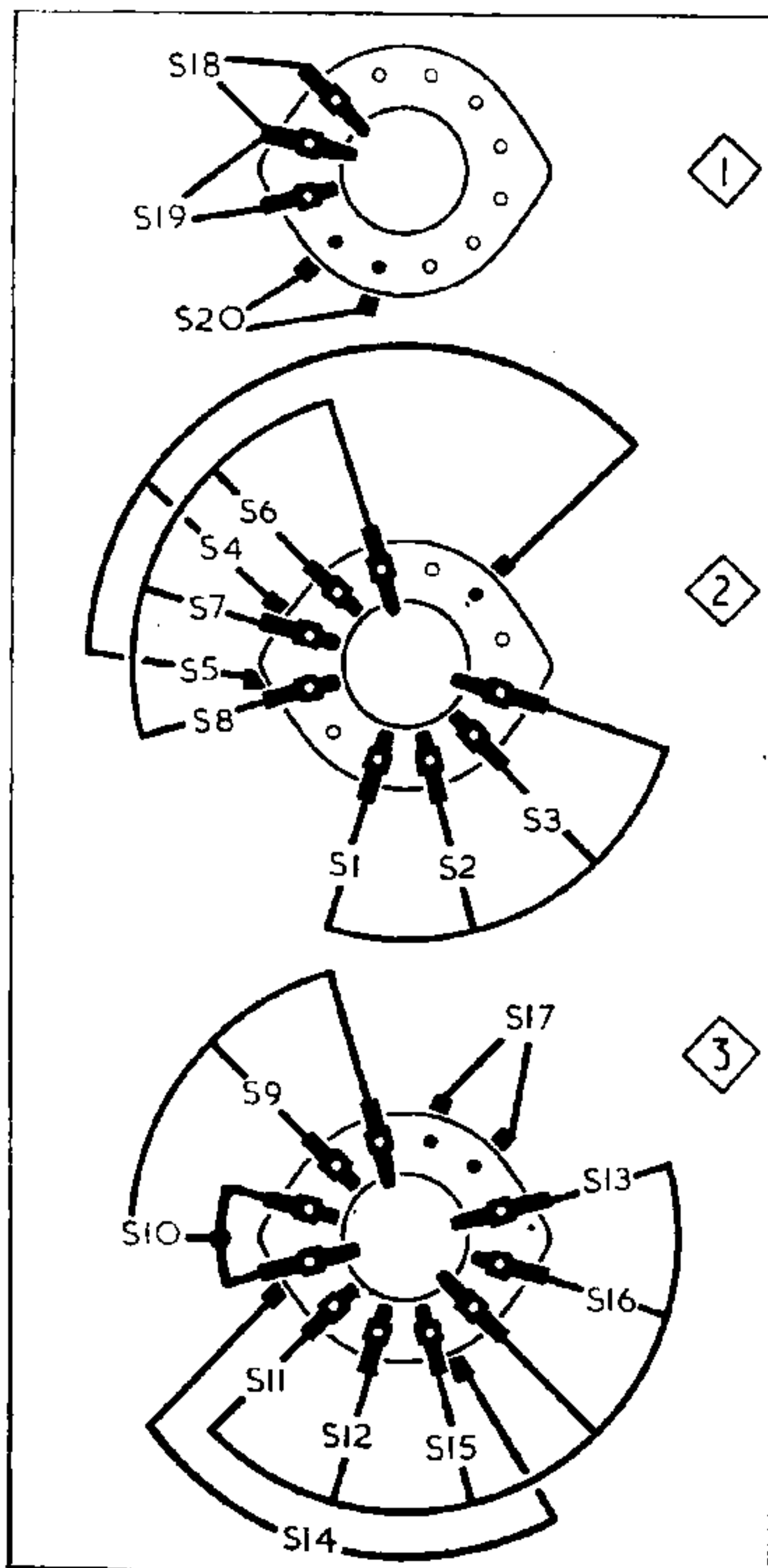

Diagrams of the waveband switch units, drawn as seen from the rear of an inverted chassis. Beside the diagrams in the next column is the associated switch table.

signal and adjust C41 (G4) and C38 (F3) for maximum output. Repeat these adjustments until no further improvement results.

M.W.—Switch receiver to M.W., tune to 200 m (164 on scale), feed in a 200 m (1,500 kc/s) signal and adjust C42 (G4) and C37 (G3) for maximum output. Feed in a 500 m (600 kc/s) signal, tune the receiver for maximum output and check that the substitute scale reading is between 32.5 and 34.5.

S.W.—Switch receiver to S.W., tune to 19.7 m (150 on scale) feed in a 19.7 m (15.23 Mc/s) signal and adjust C40 (G4) and C36 (F3) for maximum output. Rock gang while adjusting

| | S.W. | M.W. | L.W. | Gram. |
|-----|------|------|------|-------|
| S1 | C | — | — | — |
| S2 | — | C | — | — |
| S3 | — | — | C | — |
| S4 | C | — | — | — |
| S5 | C | C | — | — |
| S6 | C | C | — | — |
| S7 | — | C | — | — |
| S8 | — | — | C | — |
| S9 | C | — | — | — |
| S10 | C | C | — | — |
| S11 | C | — | — | — |
| S12 | — | C | — | — |
| S13 | — | C | C | C |
| S14 | C | — | — | — |
| S15 | — | C | — | — |
| S16 | — | C | C | — |
| S17 | C | C | C | — |
| S18 | C | C | C | — |
| S19 | — | — | — | C |
| S20 | — | — | — | C |

C36 for optimum results. Feed in a 41.4 m (7.25 Mc/s) signal, tune receiver for maximum output, and check that the substitute scale reading is between 49.5 and 53.5.

If the reading falls outside these limits the inductance of L10 and L5 should be adjusted by spacing the end turns of the coils until calibration is correct. Readjust C40 and C36 at 19.7 m (15.23 Mc/s) after making these adjustments.

I.F. Filter.—The core of L1 (A1) has been accurately set at the factory and should not need readjustment. If necessary, however, the core can be moved with a non-metallic tool and should be adjusted for maximum voltage at V1 or V2 cathode, feeding a 465 kc/s signal into the A and E sockets.

DISMANTLING THE SET

Removing Chassis.—Remove four control knobs (recessed grub screws); withdraw speaker plugs from rear of chassis and release drive cord from cursor carriage clamp; remove the two scale lamp holders from the brackets on the scale backing plate; release earthing lead from beneath left-hand lower fixing nut of scale backing plate; slacken off the two hexagonal nuts on top of the tuning indicator supporting bracket and withdraw indicator complete with bracket; release earthing lead from beneath 4BA nut and bolt above aerial socket; remove four bolts securing ends of chassis to cabinet and withdraw chassis.

GENERAL NOTES

Switches.—S1-S16 are the waveband switches, and S17-S20 are the radio/gram change-over switches, ganged in three rotary units beneath the chassis. These units are indicated in our underside drawing of the chassis, where they are identified by the numbers 1, 2, 3 in diamond surrounds. They are shown in detail in the diagrams in col. 2, where they are drawn as seen when viewed from the rear of an inverted chassis.

The table beside them gives the switch positions for the four control settings, starting from the fully anti-clockwise position of the control knob. A dash indicates open, and C, closed.

S21-S26 are the tone control switches, ganged in a single 5-position rotary unit with which is also ganged the double-pole mains switch unit S27, S28. This is shown in our underside drawing of the chassis, and the diagram in col. 4 shows the unit in detail as seen from the rear of an inverted chassis. The table below it gives the switch positions for the five control settings, starting from "off." A dash indicates open, and C, closed.

Scale Lamps.—These have small, clear, spherical bulbs and M.E.S. bases, and are rated at 6.5 V, 0.3 A.

External Speaker.—Two sockets are provided at the rear of the chassis for the connection of the internal speaker, and the speaker plugs themselves carry sockets into which the plugs of an external speaker of low impedance (about 3-7 Ω) can be inserted, so that both speakers operate together. Either speaker can thus be muted if desired by withdrawing one of its plugs.

Safety Devices.—In order to isolate the receiver properly from the mains upon switching off, double-pole Q.M.B. mains switches are

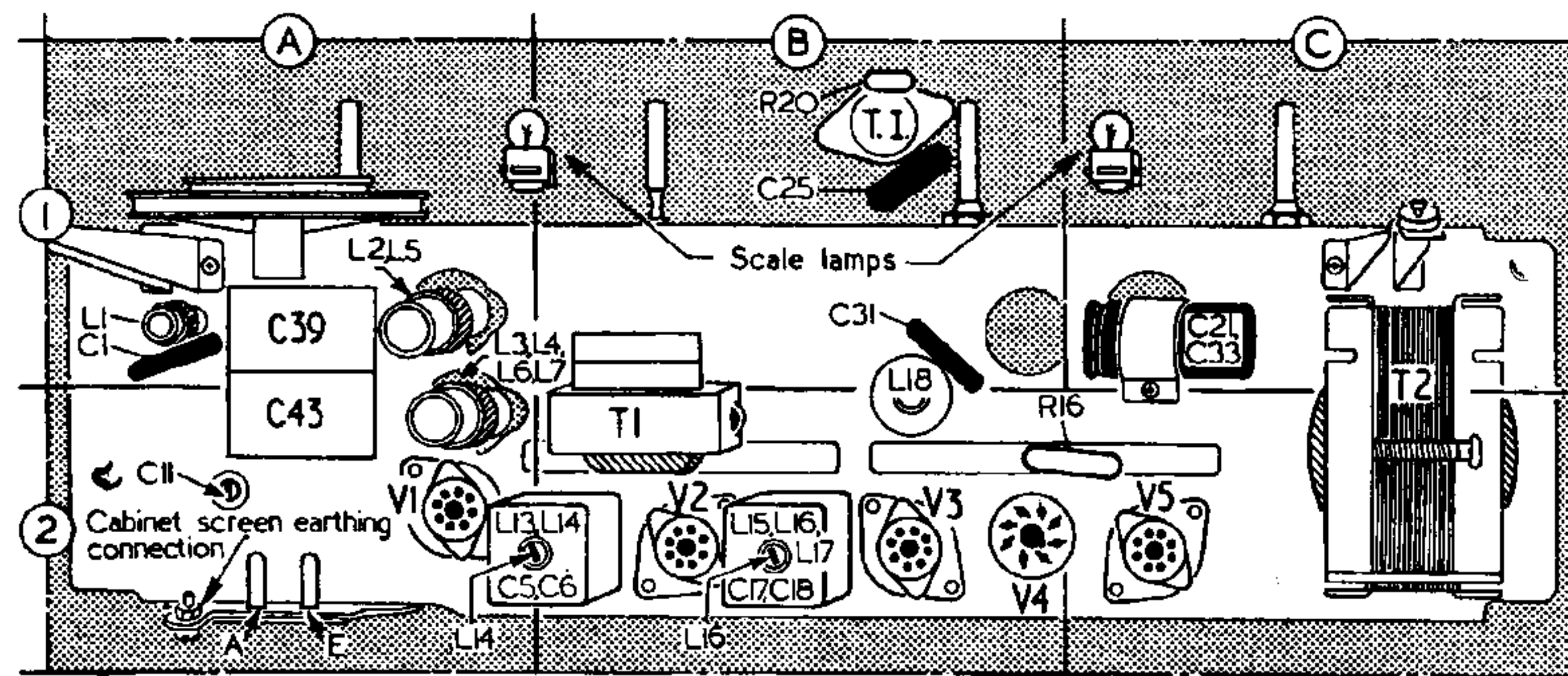

Plan view of the chassis. The temperature fuse consists of a phosphor-bronze strip held to a copper bar embedded in the mains transformer by a low melting-point alloy. It is on the right-hand face of T2. "C11" in location A2 should read "L11".

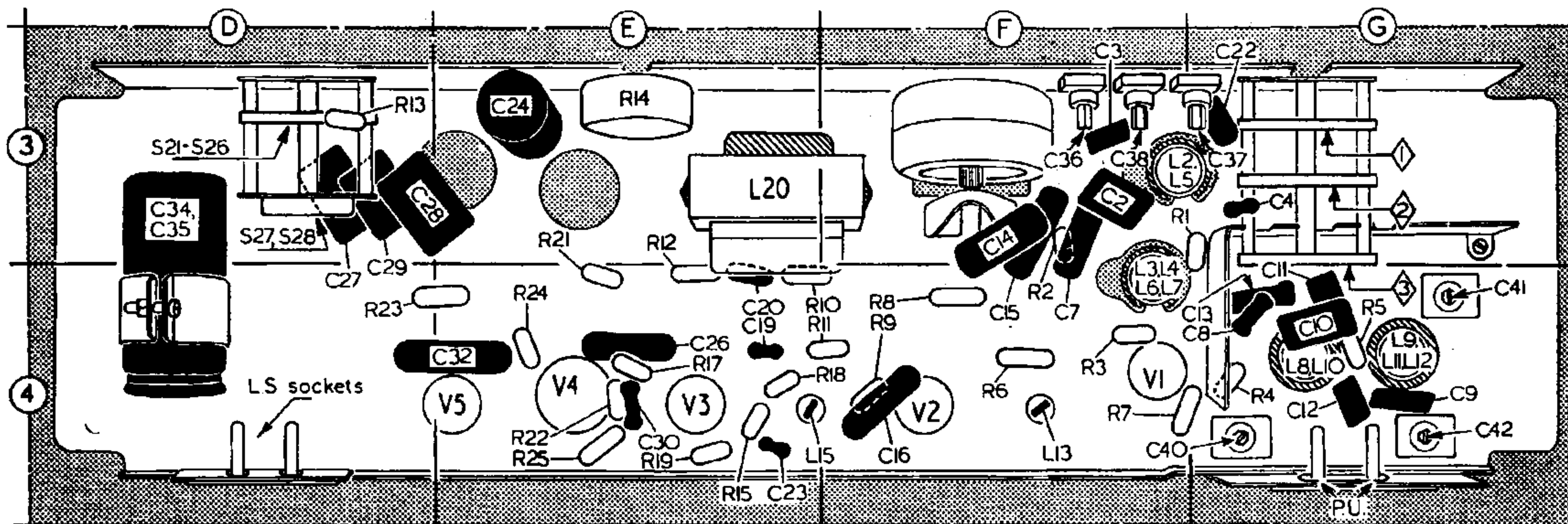

Underside drawing of the chassis. The waveband switch units are indicated by arrows and the numbers 1, 2, 3 in diamond surrounds. They are shown in detail in the diagrams in col. 2. Many of the small components are mounted on a tag board that runs along the centre of the chassis.

fitted, the mains transformer is double-wound, and a 3-core mains cable is provided. In order to avoid the risk of fire due to overheating as a result of a fault, two other devices are used.

One is a **temperature fuse** in the mains transformer primary circuit, so arranged that it opens the primary if the transformer becomes overheated. It consists of a special alloy with a low melting point, which fuses at a temperature just below the boiling point of water, and this is deposited on a copper bar embedded in the transformer.

A spring contact is held in tension to the bar by the alloy, and if the alloy melts it springs away from the bar and opens the circuit. To replace the spring it is important to use the correct metal (fusible alloy 0075/1, which can be obtained from the makers) and to apply it with a clean soldering iron that has been filed free of solder. No flux should be used.

Sufficient of the alloy is deposited during production to permit its re-use several times without a new supply, but the original deposit should not be entirely removed, as the process of applying a new deposit on cleaned metal is rather specialized.

The second takes the form of a feed resistor to a branch of the H.T. circuit to subsidiary circuits. The feed resistor is **R16**, and it is so designed that if a fault in the subsidiary circuits causes overheating, it becomes overheated and cuts off the H.T. supply to the faulty circuit. **R16** is mounted on the chassis deck, so that it is clear of all other components. Replacements should be of the same type (part No. 25086 at makers) and should be fitted in the same position.

Diagram of the tone control switch unit, as seen from the rear. Below it is the associated table.

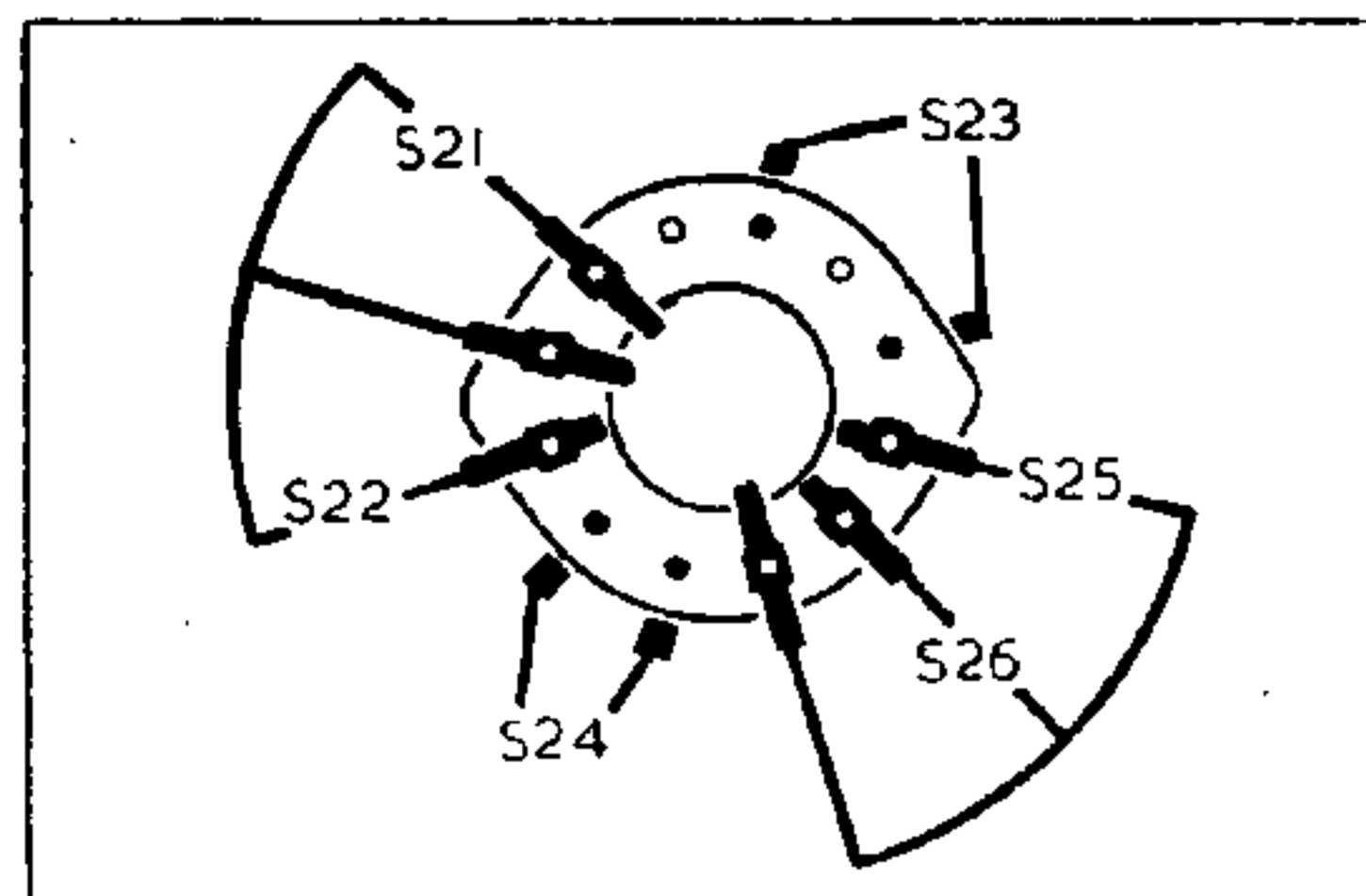

| | Off | 1 | 2 | 3 | 4 |
|-----|-----|---|---|---|---|
| S21 | — | C | C | C | — |
| S22 | — | — | — | — | C |
| S23 | — | — | — | — | C |
| S24 | — | — | C | C | — |
| S25 | — | — | — | — | — |
| S26 | — | C | — | — | — |

Aerial Rejectors.—Where whistles are produced due to the proximity of a powerful transmitter which causes overloading of the frequency changer, rejectors may be fitted in series with the aerial lead. Rejectors for 200-300 m, 300-428 m and 428-600 m are available from the makers, and provision is made for mounting them on the aerial connecting panel bracket. They may be obtained as single or double units, and are connected into circuit without any soldering as they are provided with their own aerial socket and a lead which plugs into the original aerial socket.

They are usually necessary when the receiver is installed within 9 miles of a 100 kW transmitter, or 7 miles at 60 kW, 4 miles at 10 kW, 2 miles at 2 kW or 1½ miles at 1 kW. They are adjusted by tuning in the offending station with the aerial connected to its new socket and tuning them for maximum voltage at **V1** or **V2** cathode. The cathode pins can be reached with a test prod without removing the chassis from its cabinet.

Drive Cord Replacement.—Two separate drive cords are used in this receiver, the gang drive cord and the cursor drive cord, and the makers quote the lengths required for replacement as 28in and 60in respectively. To fit a new cord, it is necessary to remove the chassis from its cabinet. Supplies of cord (part No. 3962/1) and springs (part No. 19448) can be obtained from the makers, and the cords should be stretched by hanging a weight of several pounds on them for a few hours before fitting.

It is unimportant which cord is fitted first, but the (shorter) gang drive is the outer one: that is to say, farther from the chassis. The tension should be such that the springs are extended to about 1in each.

MODIFICATIONS

Gang Drive Drum.—Our sample receiver was fitted with a moulded drum, graded 0-180 degrees, but later types have a metal drum on which the zero mark of the older drum corresponded with 60, so that all readings quoted for the old drum have to be increased by 60 to correspond on the later one. This is explained again under "Circuit Alignment."

Cabinet Screen.—In early models the metal foil on the base of the cabinet was connected by a flexible lead to a nut and bolt in a hole in the aerial panel support bracket, but in later models a different method is adopted.

Capacitors C21, C33.—In some receivers these two capacitors were in separate units, owing to a temporary shortage of the specified component.

Safety Resistor R16.—Owing to temporary shortage also **R16** may consist of two 4.7 kΩ resistors in parallel instead of the specified single 2.2 kΩ resistor. They were, however, of the same special type, and replacements should be made with the correct unit, as explained under "Safety Devices" in "General Notes."

Alternative Valves.—**V2** may be a Mazda 6F15 or a 6F16, and all but a very few chassis are wired so that either can be used. The only difference is that where the internal shield and suppressor (pins 3 and 4) are connected to the cathode (pin 7), either valve may be used; in early chassis pins 3 and 4 were connected to the spigot and chassis, with which arrangement

only the 6F15 valve can be used. In either arrangement the spigot remains connected to chassis.

The tuning indicator **T.I.** may be Mazda 6M1 or a Mullard EM34, and our base diagrams beneath the circuit show the connections for both types, which are not interchangeable.

To change from a 6M1 to an EM34 a 1 Meg resistor must be added to feed the second triode anode, and the wiring to the valve holder must be changed to suit the different arrangement of pin connections, although the holder in both cases is an international octal. In addition, where the Mullard valve is used, a rubber packing piece is necessary to accommodate its slimmer base in the fixing clamp.

Dublin Models.—These chassis were constructed in Dublin and involve two differences from the Welwyn-produced chassis. First, instead of the parallel-tuned rejector circuit in series with the aerial lead used in the Welwyn chassis, a series-tuned I.F. filter is shunted

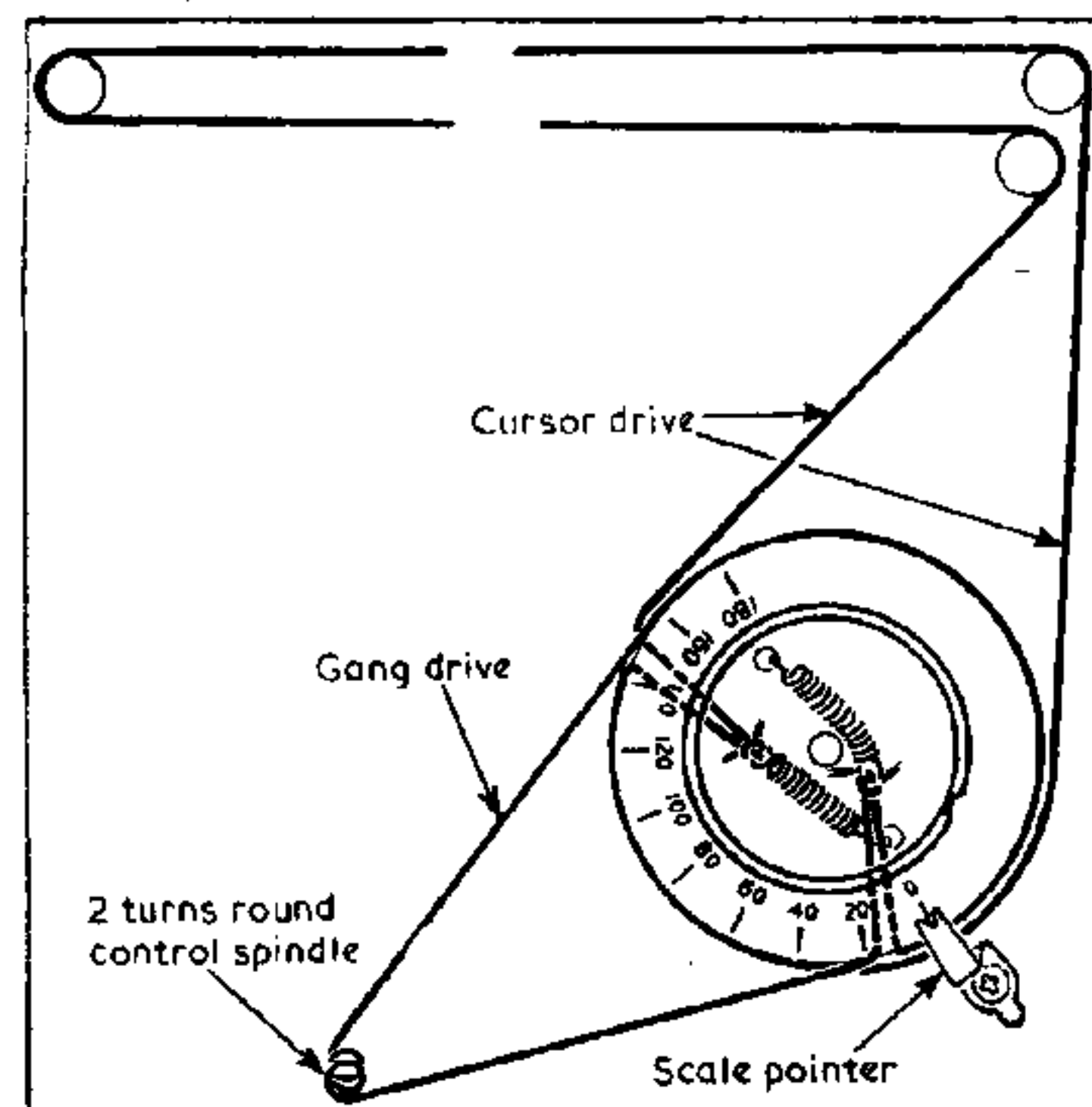

Sketch showing the tuning drive system, drawn as seen from the front with the gang at maximum capacitance.

across the aerial circuit. Secondly, the third (earth) wire in the mains lead is omitted.

Radiogram Modifications.—The radiogram version A170R employs an A170 Dublin chassis, and there was no Welwyn version. It is fitted with a Garrard RC72 or RC72A record changer, and an RC filter is connected in the leads from the pick-up. This consists of a 270 kΩ resistor shunted across the pick-up leads, and then a 220 kΩ resistor and a 390 pF capacitor in series shunted across that resistor, with the capacitor at the low potential end. The pick-up output to the P.U. sockets of the receiver is taken from the two sides of the capacitor.

Between the filter and the pick-up is an adaptor, coded red spot for 33½ R.P.M. records, or plain for 78 R.P.M. In the red spot adaptor the two leads go straight through to the filter without correction, but in the plain one a 100 kΩ resistor is connected between the two leads.