

LAFAYETTE

*HE-30*

COMMUNICATIONS  
RECEIVER

Ned. Ver. v. Historie v/d Radio

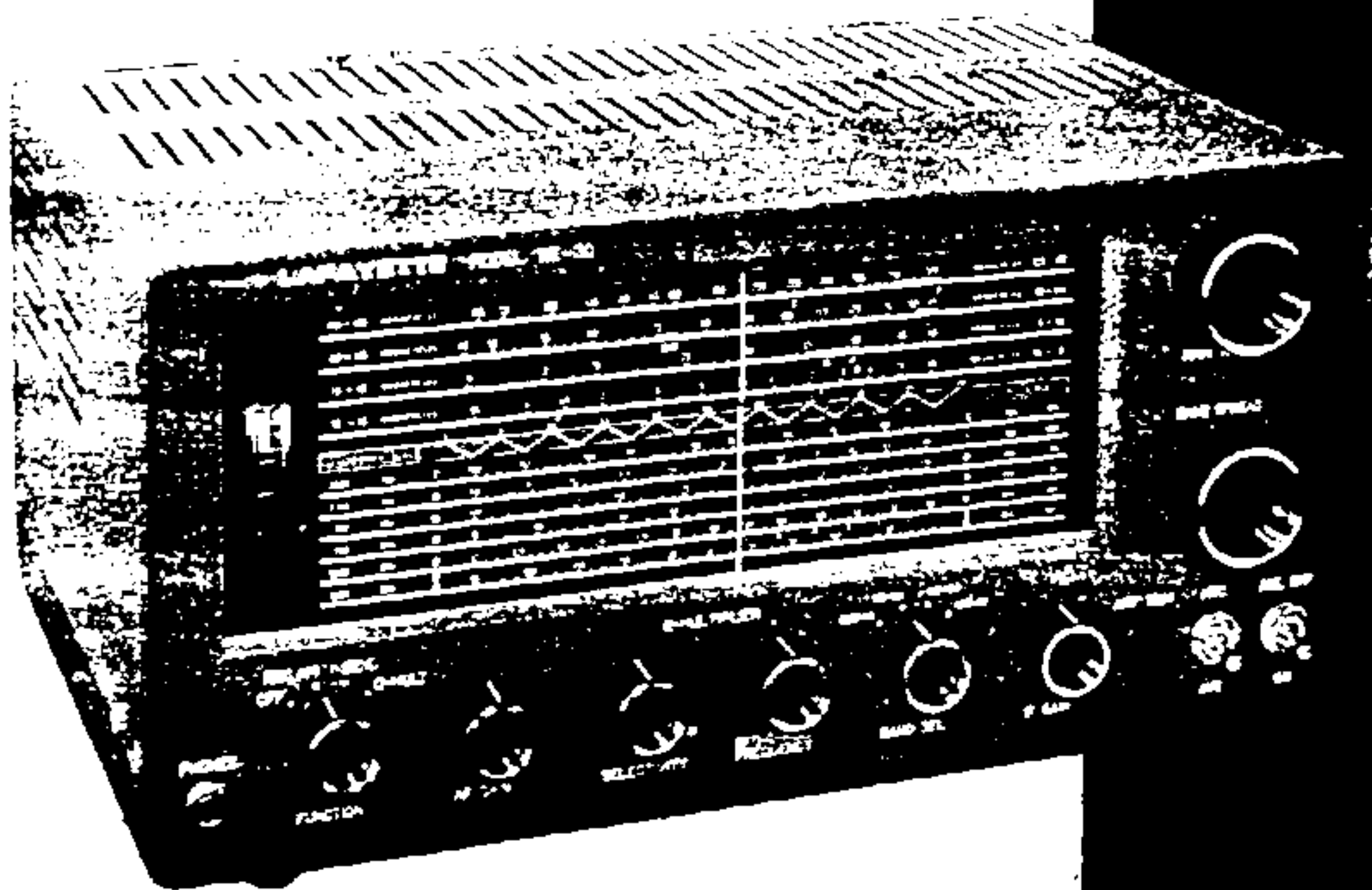
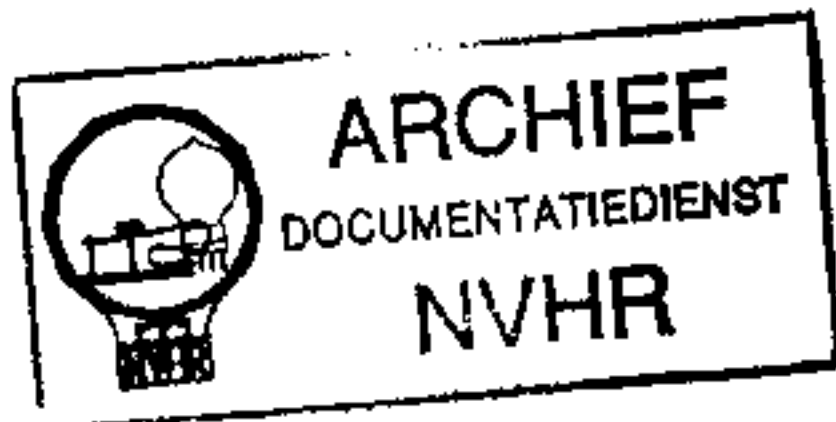

operating manual

## TECHNICAL SPECIFICATIONS

FREQUENCY RANGES.....	BAND A 550 - 1600 Kcs BAND B 1.6 - 4.8 Mcs BAND C 4.8 - 14.5 Mcs BAND D 10.3 - 30 Mcs
BANDSPREAD.....	Calibrated Electrical Bandspread 80 and 40 meters, 5 Kcs per division 20 and 15 meters, 20 Kcs per division 10 meters, 50 Kcs per division
ANTENNA INPUT.....	50 - 400 ohms impedance
AUDIO POWER OUTPUT.....	1.5 watts
SENSITIVITY.....	1 $\mu$ v for 10 db S/N Ratio
SELECTIVITY.....	$\pm$ 10 Kc at -60 db ( $\pm$ 2 Kc at -6 db) without Q-Multiplier $\pm$ 0.8 Kcs at -6 db with Q-Multiplier
SPEAKER OUTPUT.....	4 or 8 ohms
HEADPHONE OUTPUT.....	Low Impedance
POWER CONSUMPTION.....	50 watts at 117 volts AC, 60 cps
TUBE COMPLEMENT.....	V1 - 6BA6 RF Amplifier V2 - 6BE6 Mixer V3 - 6BE6 HF Oscillator V4 - 6AV6 Q-Multiplier-BFO V5 - 6BA6 1st IF Amplifier V6 - 6BA6 2nd IF Amplifier V7 - 6AV6 Detector, 1st AF Amplifier, ANL, AVC V8 - 6AQ5 Audio Output V9 - 5Y3 Rectifier
DIMENSIONS.....	7" H x 15" W x 10" D
WEIGHT.....	21 lbs

ENTIRE CONTENTS COPYRIGHT 1961 BY LAFAYETTE RADIO ELECTRONICS CORP.  
165-08 LIBERTY AVE., JAMAICA 33, N. Y.

# UNPACKING INSTRUCTIONS

After unpacking the receiver, carefully check for possible damage which may have occurred in transit. Should any signs of damage be apparent (tubes broken, case dented, etc.), notify the store from which it was purchased. If the unit was shipped to you, also file a claim with the carrier.

The following accessories should be included in the carton:

- 1 Standard Phone Plug
- 1 Jumper Plug (for the auxiliary control socket)

## INSTALLATION

### POWER SOURCE

The receiver is designed to operate from a 90-125 volt, 50-60 cycle AC power source. DO NOT OPERATE FROM A DC SOURCE. The receiver is equipped with a voltage selector switch (located within the unit). This switch should normally be left in the 117V position.

### SPEAKER CONNECTION

A three-terminal strip marked OUTPUT is provided at the rear of the receiver for speaker connections. Any PM speaker with either 4 or 8 ohm impedance can be used. Simply connect one lead to the ground terminal "O" and the other lead to the terminal that corresponds to the speaker impedance. The output power of the receiver is sufficient to drive a 4 - 12 inch PM speaker adequately.

### HEADPHONES

A standard phone jack is provided on the front panel of the receiver for headphone reception. Low impedance (8-16 ohms) headphones are recommended for optimum results. Insertion of a phone plug into the jack automatically disconnects any speaker attached to the 8 ohm output terminal.

## ANTENNAS

The terminals marked "A1", "A2", and "E" at the rear of the receiver are for antenna and ground connections. Either of the following two types of connections can be used to obtain satisfactory results.

### INVERTED L ANTENNA

The inverted L type of antenna will provide satisfactory performance over the entire tuning range. Simply short A2 and E with a jumper wire, and connect one end of the antenna wire to A1. For good reception, the antenna wire should be placed as high as possible and 50-100 feet long (see Fig. 1). In some instances, a wire connected from terminal "E" to a water pipe may improve reception.

### DOUBLET ANTENNA

A doublet antenna will give excellent results, especially on amateur bands. A 75 ohms balanced transmission line should be used (as shown in Fig. 2). Since the doublet antenna provides optimum performance only at a given frequency, it should be cut to the length for the most often used band of frequencies. The overall length of a doublet antenna can be determined by using the following formula:

$$L \text{ (Length in feet)} = \frac{468}{\text{Frequency in megacycles}}$$

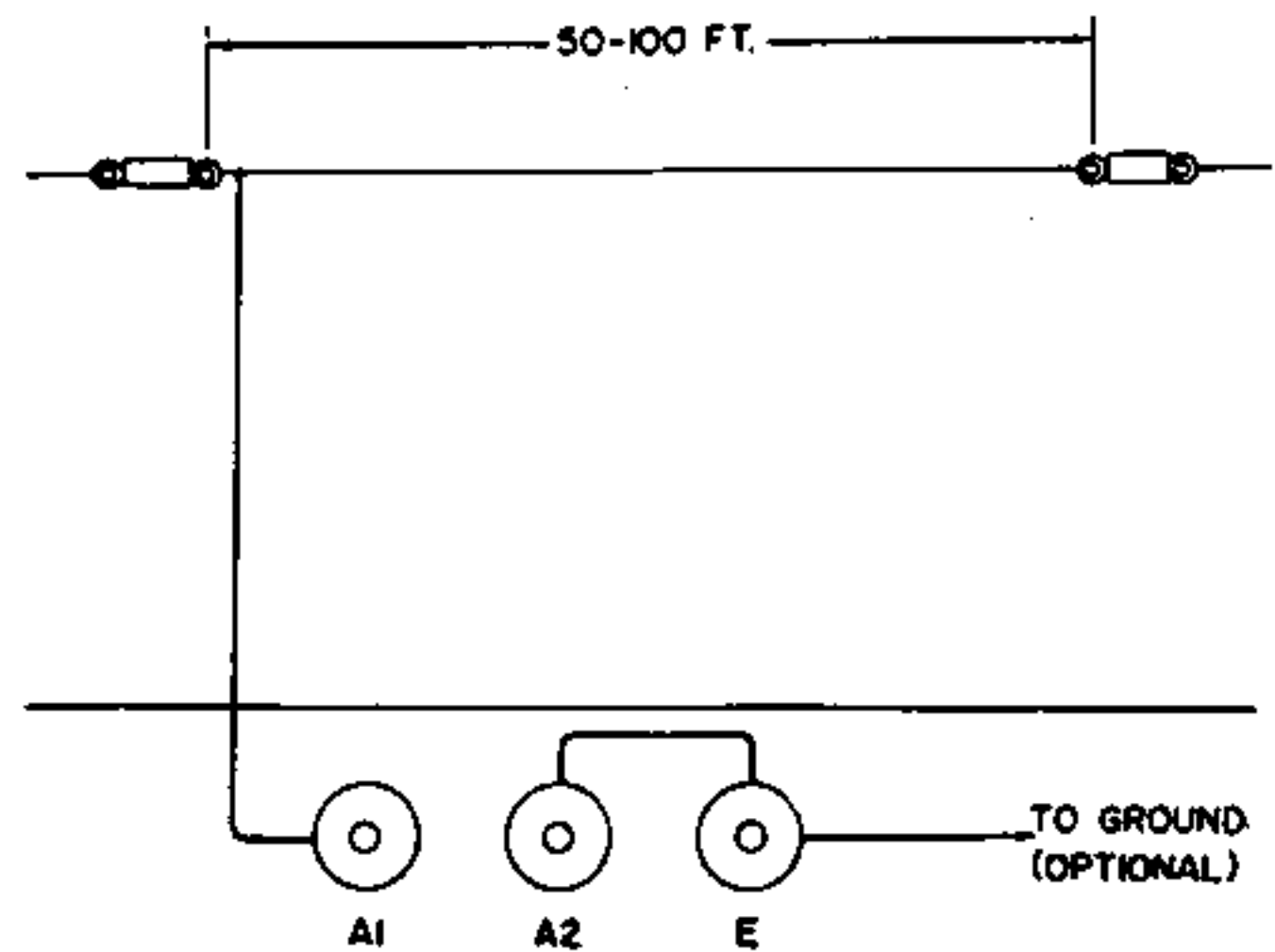

**FIGURE 1**  
Single Wire Antenna (Inverted L)

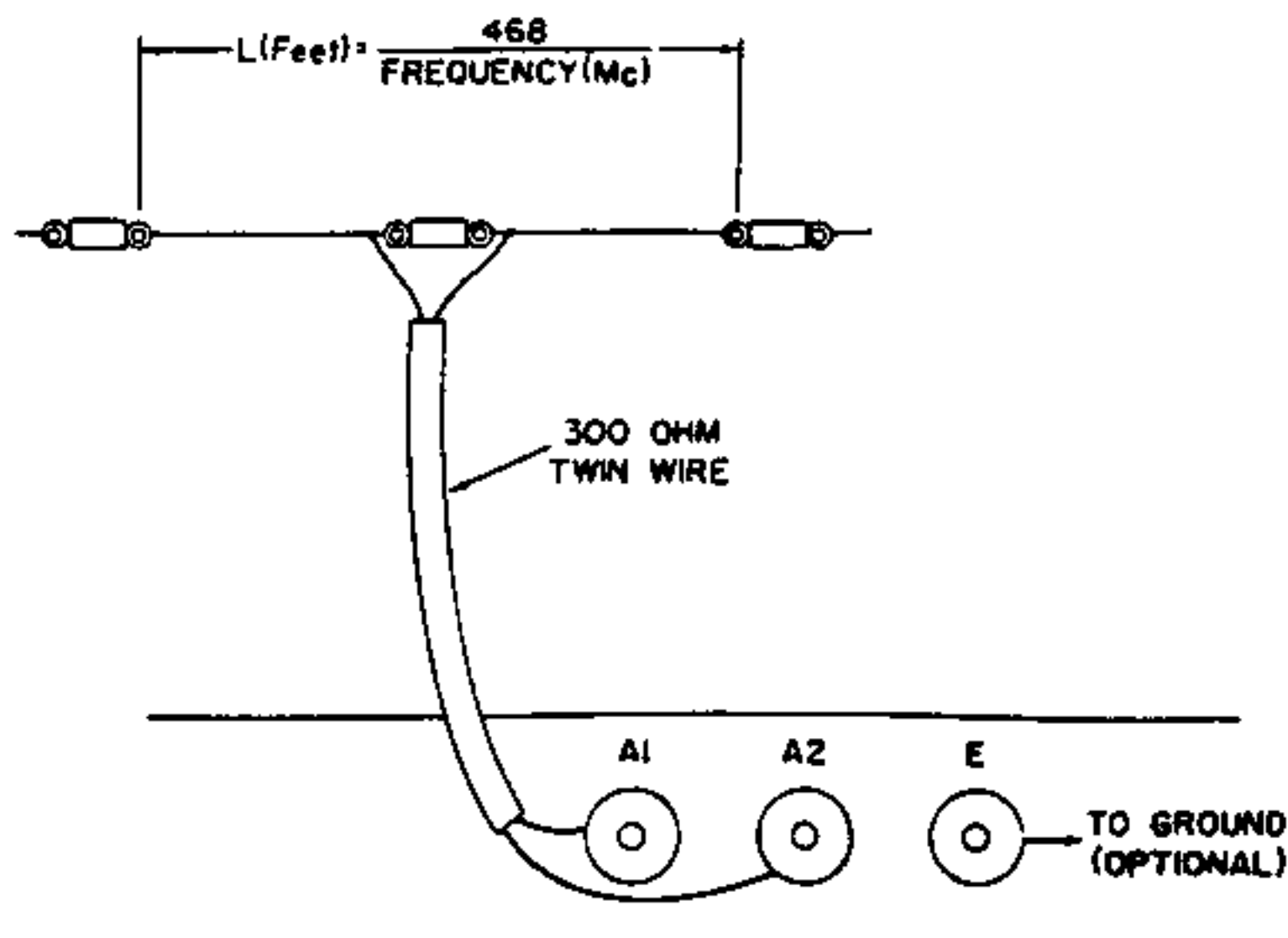

**FIGURE 2**  
Doublet Antenna

Since the doublet antenna displays directional properties broadside to its length, it should be oriented in such a manner that maximum signal pickup can be realized.

When using either a balanced transmission line or a twisted pair, the leads connect to terminals "A1" and "A2" respectively, and the jumper wire between "A2" and "E" is removed. A height of 30-50 feet is recommended for good reception of weak signals.

#### FUSE

A 2 amp fuse is located at the rear of the receiver. To remove it, unscrew the spring loaded cap. Replace only with one of a similar rating.

#### AUXILIARY CONTROL

A socket in the back of the receiver allows simultaneous control of this receiver with a transmitter. An external switching device can be constructed so that the receiver will be inoperative during periods of

transmission. In this case, the FUNCTION switch is placed in the SEND position. The external switch is attached to the 5-pin plug so that pins 3 and 2 (see Fig. 3) will be connected when signal reception is desired. This plug is then inserted into the socket in place of the jumper plug. In this manner, signal reception will be instantaneous, as plate voltage will be applied to the RF stages when the switch is closed accordingly.

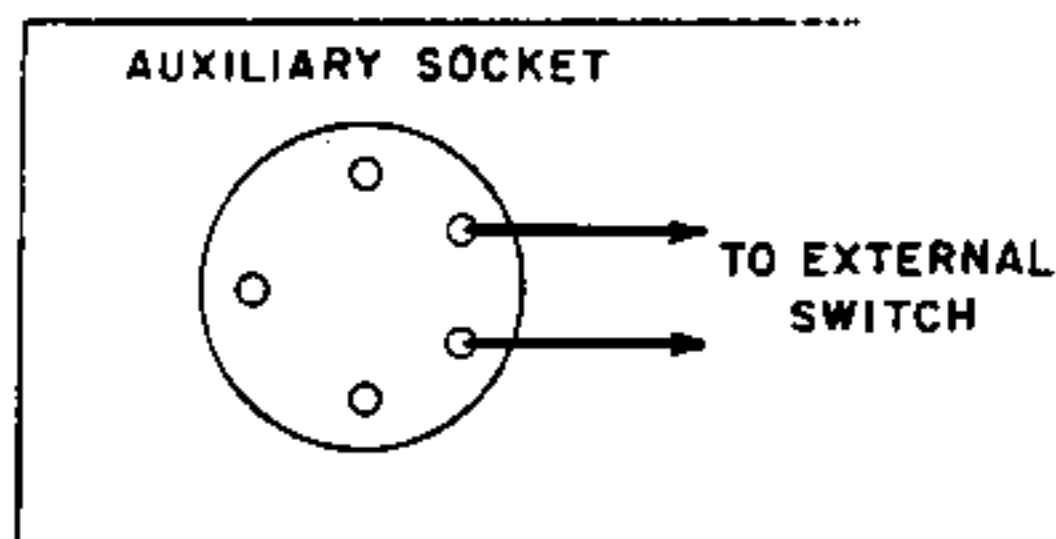

**FIGURE 3**  
Auxiliary Control Socket

For normal operating conditions with no external switching, the jumper plug provided must be inserted into the socket. Pins 3 and 2 of the plug are shorted, thus providing plate voltage to the RF stages. To disable the receiver under these conditions, set the FUNCTION switch to the SEND position. In this position plate voltages to the RF stages are cut off. Returning the switch to REC AM will provide instantaneous signal reception.

## INITIAL CONTROL SETTINGS

CONTROL	AM SETTINGS	CW SETTINGS	SSB SETTINGS
FUNCTION	REC AM	Q-MULT	Q-MULT
BAND SEL	Set for desired range	Set for desired range	Set for desired range
SELECTIVITY	CW-SSB*	CW-SSB	CW-SSB
BFO-Q-MULT FREQUENCY	Mid-position	Mid-position	Mid-position
IF GAIN	Maximum	Adjust for desired audio level	Adjust for desired audio level
ANT TRIM	12 o'clock position	12 o'clock position	12 o'clock position
MVC-AVC	AVC	MVC	MVC
ANL OFF-ON	Optional	Optional	OFF
BANDSPREAD	Set to 100 on Logging Scale	Set to 100 on Logging Scale	Set to 100 on Logging Scale
AF GAIN	Adjust for desired audio level	2/3 to 3/4 clockwise	2/3 to 3/4 clockwise

\* Setting the SELECTIVITY control to CW-SSB with the FUNCTION switch in REC AM disconnects the Q-Multiplier from the IF, allowing normal IF band pass.

### THE Q-MULTIPLIER CIRCUIT

A Q-Multiplier provides the additional selectivity often required for optimum reception of signals in the congested short-wave bands. In your receiver, the Q-Multiplier circuit serves a dual function - Q-Multiplier and BFO. For CW and SSB reception, the circuit is employed as a BFO. The circuit may be employed as a Q-Multiplier during phone reception if conditions require the use of additional selectivity.

A little experience in using the Q-Multiplier will be necessary for optimum results under different receiving conditions. In the hands of an experienced operator, the Q-Multiplier is a very handy tool, and will greatly enhance the performance of the receiver.

The controls associated with the Q-Multiplier circuit are the SELECTIVITY and BFO-Q-MULT FREQUENCY controls. They are not operative unless the Function switch is in the Q-MULT position.

#### SELECTIVITY CONTROL

When the SELECTIVITY control is in the CW-SSB position, the circuit oscillates, thus providing the beat signal necessary for CW or SSB reception. Off the CW-SSB position, the circuit is connected to the IF stage and now acts as a narrow gate through which the IF signals must pass. The width of the "gate" is determined by the position of the SELECTIVITY control. Advancing the control from the fully counter-clockwise position serves to peak the signal increasingly until a point of oscillation is reached. Sharpest selectivity is reached just prior to oscillation.

#### BFO-Q-MULT FREQUENCY CONTROL

The action of this control is determined by the position of the SELECTIVITY control. When the Selectivity control is set to CW-SSB, the BFO-Q-MULT FREQUENCY control is used to vary pitch for CW reception or to provide clarity of signal for SSB reception.

When the Selectivity control is used to increase selectivity during Q-Multiplier operation, (as described previously), the sharp peak produced can be moved around within the IF pass band by means of the BFO-Q-MULT FREQUENCY CONTROL to reduce or eliminate interference from adjacent signals.

## USING THE CIRCUIT AS A Q-MULTIPLIER

Initially, all controls on the receiver should be set to the positions indicated in the chart for AM settings. Tune in desired station. Set SELECTIVITY to the fully counter-clockwise position and FUNCTION to "Q-Mult". Increase AF gain if necessary. Advance the SELECTIVITY control until the desired degree of selectivity is obtained. The point of maximum selectivity is reached just before the circuit breaks into oscillation. The BFO-Q-MULT FREQUENCY control may now be adjusted to provide a reduction, or to eliminate, any adjacent channel interference.

## USING THE CIRCUIT AS A BFO

Initially, all controls should be set as indicated in the chart for CW or SSB operation. Under these conditions the BFO-Q-MULT FREQUENCY control is used to vary the pitch (CW) or for clarity of signal (SSB). The SELECTIVITY control remains permanently in the CW-SSB position for CW or SSB reception.

## TUNING

The main tuning and bandspread dials are calibrated in megacycles and contain special markings to simplify tuning. The major amateur radio bands are contained in the 1.6 to 4.8, 4.8 to 14.5 and 10.3 to 30.00 megacycle bands. The location of each amateur band is indicated by heavy white scale lines on the main tuning dial. The circled letter or letters which appear with each band indicate the bandspread scale to be used. Calibration of the main tuning scales is correct when the bandspread pointer is set at 100 on the LOGGING SCALE.

Bandspreading on the amateur bands is carried out in the following manner: Set the bandspread pointer initially to 100 and the main tuning pointer directly over the circled letter for the band to be tuned. In some cases the band is split between two such letters. For example, B1 and B2 together cover the range of 7.0 to 7.35 megacycles - B1 from 7.0 to 7.17, B2 from 7.17 to 7.35 megacycles. The calibrated bandspread scale which is used is indicated to the right and left-hand side. Thus, if the main tuning pointer is set over B1, the bandspread scale in use is the one marked B1, the fourth one down. Tuning is then accomplished solely with the BANDSPREAD control.

Short-wave bandspreading, for other than amateur bands, is accomplished by setting the bandspread pointer at 100 on the Logging Scale and the main tuning pointer at the high end of the short-wave band to be tuned. Rotate the bandspread control to tune over the band. Moving the bandspread pointer towards 0 on the logging scale subtracts from the frequency indicated on the main tuning scale. Logging of short-wave stations is possible by noting the readings on both the Main Tuning and Logging Scales.

## S - METER READINGS

The S-Meter provides a means of measuring the relative strength of incoming AM signals. Relative readings are only correct when the IF GAIN control is fully clockwise. Measurements are read in S units from 1 to 9 and in decibels above S9 from 0 to 40 db. The circuit is disabled when the MVC/AVC switch is in the MVC position.

A ZERO ADJ control at the rear of the receiver is provided for zeroing the S-Meter electrically. This adjustment is made with the antenna disconnected, IF GAIN control at maximum and AVC on.

## ANTENNA TRIMMER

The ANT TRIM control, adjustable from the front panel, acts as a compensating capacitor to permit optimum matching of the receiver to the antenna at all frequencies. Initially, the control should be set to its mid-position (the dot on the front surface of the knob at 12 o'clock position). The control should always be adjusted for maximum background noise. Each setting will be good only over a limited range of frequencies. The trimmer should therefore always be readjusted after tuning to the general area where the expected signal is to be found.

S - METER

Acts As A Tuning Indicator - Shows Relative Signal Strength

MAIN TUNING

Tunes Frequency Range Of Receiver As Determined By Band Selector Setting

BANDSPREAD

Permits Expanded Tuning Of Small Portions Of The Main Tuning Dial

ANL OFF-ON

Used To Reduce Excessive Noise From Auto Ignition, etc.

MVC-AVC

AVC Position Used To Minimize Fading Of Signals

ANT TRIM

Adjusts Receiver For Best Antenna Match Over Entire Frequency Range

IF GAIN

Adjusts IF Gain - Used As Volume Control For CW Operation

BAND SEL

Selects Tuning Range

SELECTIVITY

See section headed The Q-Multiplier Circuit

BFO - Q - MULT

FREQUENCY

AF GAIN

Adjusts Audio Output Level

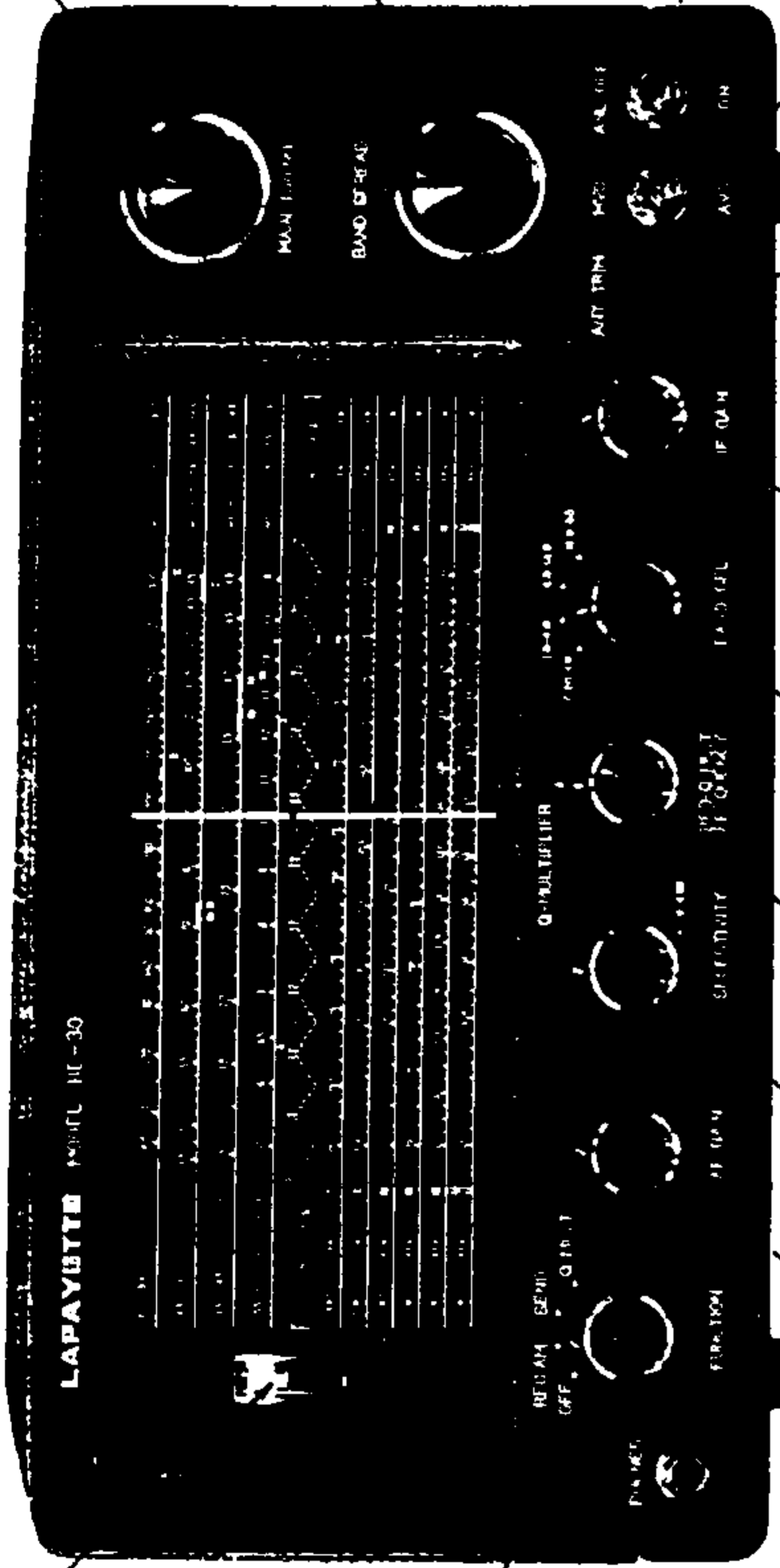

FUNCTION

Selects Mode of Operation

Q-MULTIPLIER

REG AM SEMI OFF

AF GAIN

SELECTIVITY

IF GAIN

BAND SEL

ANT TRIM

ANL

FUNCTION

IF GAIN

BAND SEL

ANT TRIM

MVC-AVC

ANT TRIM

## AM OPERATION

For the reception of broadcast stations, short-wave listening, etc., place all controls in the positions indicated in the Initial Control Settings chart. Tune in station, using Main and Bandsread tuning controls as indicated in the section under "TUNING". Adjust ANT TRIM for highest "S" meter reading on signal. This antenna control setting is satisfactory while operating over a limited frequency range. If excessive spurious noises such as those caused by auto ignition make reception difficult, place the ANL OFF switch to the ON position. The automatic noise limiter should be used only when necessary, since it tends to reduce the overall efficiency of the receiver.

If interference from nearby stations makes reception difficult, the Q-Multiplier may be employed to minimize or eliminate the interference. Since the use of the Q-Multiplier results in a narrower bandwidth it should only be employed when interference is severe and where maximum fidelity is not required.

## CW OPERATION

The control settings required for the reception of code signals are indicated in the chart. AVC is switched off and the IF GAIN control is used as a volume control. Tune signal to zero beat. The BFO-Q-MULT FREQUENCY control should then be adjusted on either side of white dot for desired pitch.

## SINGLE SIDE BAND OPERATION

The settings of controls for SSB reception is essentially the same as for CW (see chart). The BFO frequency however, is used in this case for carrier reinsertion. AVC is switched off and the IF GAIN control used to adjust the level. Tune station in with BANDSPREAD control and then adjust BFO-Q-MULT FREQUENCY control for clarity of speech. Slight readjustment of the BANDSPREAD may be necessary to provide best audio quality.

## SHORT-WAVE LISTENING

On the short-wave frequencies are to be found radio stations transmitting from all over the world. Many of these stations provide English-language broadcasts. The frequencies on which the majority of short-wave broadcast stations operate are found in the two upper bands of your receiver (4.8 to 14.5 megacycles and 10.5 to 30 megacycles). A characteristic of short-wave is that reception varies with the time of day, the season of the year and with weather conditions. In order to know just when and where to listen, a listening chart which lists English language broadcast stations best heard in North America is included in this manual. "Better Shortwave Reception" by William I. Orr (available from Lafayette Radio as BK1032) is recommended to the short-wave listener and amateur alike. It provides an introduction to short-wave radio for the beginner and presents some of the practical aspects and helpful advice for the more experienced listener.



# Listen to the Voices of the World

## ENGLISH LANGUAGE SHORT-WAVE BROADCAST STATIONS BEST HEARD IN WESTERN NORTH AMERICA

Readers in the western part of the United States and Canada will find the following list of "Best Heard" stations helpful in tuning the short-wave broadcast bands. The left-hand column lists the hour in Pacific Standard Time for broadcasts in English only; in the middle column, the city and country from which the broadcasts originate are listed with the name of the station used for identification in parentheses; and on the right are the frequencies and call letters for stations using them during their broadcasts.

TIME (PST)	CITY, COUNTRY (NAME)	FREQUENCIES (kc.)
10:30-2:45 a.m.	Wellington, New Zealand ( <i>Radio New Zealand</i> )	8540 (ZL2), 6080 (ZL7)
11:30-11:45 p.m.	Papeete, Tahiti ( <i>The Voice of France in the Pacific</i> )	6135
12:00-1:15 a.m.	Manila, Philippines ( <i>Call of the Orient</i> )	17805, 15300, 11855, 9730

### NEWS BROADCASTS FOR WESTERN NORTH AMERICA

TIME (PST)	CITY, COUNTRY (NAME)	FREQUENCIES (kc.)
4:00-6:00 a.m.	Manila, Philippines ( <i>The Call of the Orient</i> )	11855, 9730
6:30-7:30 a.m.	Djakarta, Indonesia ( <i>The Voice of Indonesia</i> )	9710, 4910
7:15-8:15 a.m.	Melbourne, Australia ( <i>Radio Australia</i> )	11770 (VLC11)
8:00-8:15 a.m.	Stockholm, Sweden ( <i>Radio Sweden</i> )	15155
10:00-1:00 p.m.	London, England ( <i>North American Service</i> )	17700, 15310
1:00-2:15 p.m.	London, England ( <i>General Overseas Service</i> )	15310, 11930
2:15-3:15 p.m.	London, England ( <i>General Overseas Service</i> )	17825 (JOA22), 16235 (JOB9)
3:00-3:30 p.m.	Tokyo, Japan ( <i>Radio Japan</i> )	11930, 9825
1:00-7:00 p.m.	London, England ( <i>General Overseas Service</i> )	17865, 15140
1:00-10:00 p.m.	Moscow, USSR ( <i>Radio Moscow</i> )	15235 (JO19), 11705 (JOA4)
4:30-4:50 p.m.	Tokyo, Japan ( <i>Radio Japan</i> )	16190 (CKCX), 11720 (CHOL)
4:55-5:45 p.m.	Montreal, Canada ( <i>Radio Canada</i> )	16400, 9856
5:00-7:30 p.m.	Cape Haitien, Haiti ( <i>The Evangelistic Voice</i> ) - no broadcast on Wednesday and Thursday	11865 (HER5), 9535 (HER4), 6165 (HER3)
5:30-7:15 p.m.	Berne, Switzerland ( <i>Switzerland Calling</i> )	15115, 11915, 9745
6:00-9:00 p.m.	Quito, Ecuador (HCJB - <i>The Voice of the Andes</i> ) - no broadcast on Monday	9575, 6010
6:25-6:45 p.m.	Rome, Italy ( <i>Italian Broadcasting &amp; TV System</i> )	11795, 9640
6:30-6:40 p.m.	Cologne, Germany ( <i>The Voice of Germany</i> )	9525, 6025
6:30-7:00 p.m.	Warsaw, Poland ( <i>Radio Warsaw</i> )	11950, 9590
6:30-7:10 p.m.	Hilversum, Holland ( <i>Radio Netherlands</i> )	11950, 9590
6:30-8:00 p.m.	Hilversum, Holland ( <i>The Happy Station</i> ) - special program on Sundays only	11950, 9590
6:45-7:00 p.m.	Brazzaville, FEA ( <i>Radio Brazzaville, French Equatorial Africa</i> )	11970, 9625
6:55-7:35 p.m.	Montreal, Canada ( <i>Radio Canada</i> )	11946 (CKNK), 9585 (CKLP)
7:00-7:30 p.m.	Bucharest, Romania ( <i>Bucharest Calling</i> )	11937, 9570
7:00-7:30 p.m.	Peking, China ( <i>Radio Peking</i> )	17745, 17720, 15150, 16118
7:00-8:30 p.m.	Prague, Czechoslovakia ( <i>Radio Prague</i> )	9585, 6170, 8105, 6055
7:00-8:45 p.m.	Guatemala City, Guatemala (TGNA)	9668, 5952
7:15-8:00 p.m.	Madrid, Spain ( <i>The Voice of Spain</i> )	9360, 6130
7:30-8:00 p.m.	Copenhagen, Denmark ( <i>The Voice of Denmark</i> ) - no English on Sundays	9520 (OZF), 16236 (JO19), 11705 (JOA4)
7:30-8:00 p.m.	Tokyo, Japan ( <i>Radio Japan</i> )	15175, 11735, 9540
8:00-8:20 p.m.	Oslo, Norway ( <i>Radio Norway</i> ) - on Sundays only	11910, 9633
8:00-8:30 p.m.	Budapest, Hungary ( <i>Radio Budapest</i> )	9700
8:00-9:30 p.m.	Sofia, Bulgaria ( <i>Sofia Calling</i> )	9647, 6037
8:00-9:00 p.m.	San Jose, Costa Rica (TIFC - <i>The Lighthouse of the Caribbean</i> )	11866 (HER5), 9636 (HER4)
8:15-9:00 p.m.	Berne, Switzerland ( <i>Switzerland Calling</i> )	9360, 6130
8:15-9:00 p.m.	Madrid, Spain ( <i>The Voice of Spain</i> )	11937, 9570
8:30-9:00 p.m.	Bucharest, Romania ( <i>Bucharest Calling</i> )	15225, 11815
9:00-9:30 p.m.	Taipei, Taiwan ( <i>The Voice of Free China</i> )	9620
9:00-9:30 p.m.	Stockholm, Sweden ( <i>Radio Sweden</i> )	11970
9:15-9:30 p.m.	Brazzaville, FEA ( <i>Radio Brazzaville, French Equatorial Africa</i> )	9360, 6130
9:15-10:00 p.m.	Madrid, Spain ( <i>The Voice of Spain</i> )	9525, 6025
9:30-10:00 p.m.	Warsaw, Poland ( <i>Radio Warsaw</i> )	15225, 11815
10:30-11:00 p.m.	Taipei, Taiwan ( <i>The Voice of Free China</i> )	

The following listing of news broadcasts has been prepared for those readers living in the Western United States and Canada. Times are given in Pacific Standard Time and the frequencies in kilocycles.

TIME (PST)	CITY AND COUNTRY	FREQUENCIES (kc.)
6:45 a.m.	Djakarta, Indonesia	9710, 4910
7:00 a.m.	Manila, Philippines	11855, 9730
7:30 a.m.	Melbourne, Australia	11770
8:00 a.m.	Stockholm, Sweden	15155
9:00 a.m.	London, England	17700
12:00 Noon	London, England	15310, 11930, 9825
3:00 p.m.	London, England	17825, 15235
3:00 p.m.	Tokyo, Japan	17845, 15140
3:00 p.m.	Moscow, USSR	17845, 15140
4:00 p.m.	Moscow, USSR	17720, 15140
4:30 p.m.	Delhi, India	15235, 11705
4:30 p.m.	Tokyo, Japan	15190, 11720
5:00 p.m.	Montreal, Canada	17845, 15140
5:00 p.m.	Moscow, USSR	17750, 15335
5:30 p.m.	Karachi, Pakistan	15190, 11720
5:30 p.m.	Montreal, Canada	11845, 9535, 4165
5:35 p.m.	Berne, Switzerland	11930, 9825
6:00 p.m.	London, England	17845, 15140
6:00 p.m.	Moscow, USSR	9575, 6010
6:25 p.m.	Rome, Italy	11775, 9640
6:30 p.m.	Cologne, Germany	9525, 6025
6:30 p.m.	Warsaw, Poland	11950, 9590
6:30 p.m.	Hilversum, Holland (not on Sunday)	17830, 15160, 11710
6:30 p.m.	Delhi, India	11970, 9625
6:45 p.m.	Brazzaville, French Equatorial Africa	17845, 15140
7:00 p.m.	Moscow, USSR	11945, 9585
7:00 p.m.	Montreal, Canada	11917, 9570
7:00 p.m.	Bucharest, Romania	17745, 17720, 15350, 15110
7:00 p.m.	Peking, China	9505, 6170, 4105, 4055
7:00 p.m.	Prague, Czechoslovakia	9360, 6130
7:15 p.m.	Madrid, Spain	9520
7:30 p.m.	Copenhagen, Denmark (only Mondays)	15235, 11705
7:30 p.m.	Tokyo, Japan	17865, 15140
8:00 p.m.	Moscow, USSR	15175, 11735, 9540
8:00 p.m.	Oslo, Norway (only Sundays)	9700
8:00 p.m.	Sofia, Bulgaria	9340, 4130
8:15 p.m.	Madrid, Spain	11845, 9535
8:20 p.m.	Berne, Switzerland	11937, 9570
8:30 p.m.	Bucharest, Romania	15225, 11815
9:00 p.m.	Taipei, Taiwan	9540, 6080
9:00 p.m.	Moscow, USSR	17865, 15140
9:00 p.m.	Stockholm, Sweden	9620
9:15 p.m.	Brazzaville, French Equatorial Africa	11970
9:15 p.m.	Madrid, Spain	9340, 4130
9:30 p.m.	Taipei, Taiwan	9575, 6025
9:30 p.m.	Warsaw, Poland	15225, 11815
10:30 p.m.	Taipei, Taiwan	9540, 6080
11:30 p.m.	Wellington, New Zealand	4135
11:30 p.m.	Papeete, Tahiti	6135
12:30 a.m.	Wellington, New Zealand (not on Sunday)	9540, 6080
1:00 a.m.	Manila, Philippines	11855, 9730
2:30 a.m.	Wellington, New Zealand	9540, 6080

ENGLISH LANGUAGE BROADCAST STATIONS BEST HEARD IN EASTERN NORTH AMERICA

TIME (EST)	CITY, COUNTRY (NAME)	ENGLISH LANGUAGE SHORT-WAVE BROADCAST STATIONS BEST HEARD IN EASTERN NORTH AMERICA	FREQUENCIES (kc.)	CITY AND COUNTRY	FREQUENCIES (kc.)
6:00-6:30 a.m.	Warsaw, Poland (Radio Warsaw)		17000, 15120	Wellington, New Zealand	9540, 4000
7:00-7:15 a.m.	Helsinki, Finland (Finland Calling) - no English on Sundays and holidays		17798, 15190	Warsaw, Poland	17800, 15120
7:15-8:15 a.m.	Warsaw, Poland (Radio Warsaw)		17800, 15120	Djakarta, Indonesia	9710
8:00-9:30 a.m.	Melbourne, Australia (Radio Australia)		11770, (V1A,11)	Helsinki, Finland	17798, 15190
8:15-8:45 a.m.	Cape Haitien, Haiti (The Evangelistic Voice) - no broadcast on Thursdays		15190, 9638	Warsaw, Poland	17800, 15120
8:45-9:15 a.m.	Stockholm, Sweden (Radio Sweden)		17840	Melbourne, Australia	17700
10:00-12:15 p.m.	London, England (North American Service)		17700	Warsaw, Poland	17800, 15120
1:00-4:00 p.m.	London, England (North American Service)		17700	Stockholm, Sweden	17840
4:00-5:15 p.m.	London, England (General Overseas Service)		17700, 15310, 9008	Melbourne, Australia	11770
4:15-4:45 p.m.	Hilversum, Holland (Radio Netherlands) - no English on Sundays		15365, 11950	Lisbon, Portugal	21495, 17895
4:30-5:20 p.m.	Jerusalem, Israel (The Voice of Zion)		9008	London, England	17700
5:00-5:30 p.m.	Port-au-Prince, Haiti (Radio Commerce) - on Sundays only		9482 (4VC)	Lisbon, Portugal	21700, 17895
5:15-6:15 p.m.	London, England (General Overseas Service)		15310, 11930	Athens, Greece	17775, 15345
6:00-6:30 p.m.	Tokyo, Japan (Radio Japan)		17825 (JOA22), 15235 (JOB8)	London, England	17700
6:00-10:00 p.m.	London, England (General Overseas Service)		11930, 9825	Tehran, Iran	15100
6:00-1:00 a.m.	Moscow, USSR (Radio Moscow)		11937, 11890, 11845, 11825, 11805, 11740, 11700, 9700, 9665	Damascus, Syria	17665
6:15-7:00 p.m.	Ankara, Turkey (Radio Ankara)		9615	Hilversum, Holland	15365, 11950
7:15-7:35 p.m.	Rome, Italy (Italian Broadcasting and Television System)		9675, 6010	Jerusalem, Israel	8100
7:30-7:50 p.m.	Tokyo, Japan (Radio Japan)		15235, (JOB9), 11705 (JOA4)	Belgrade, Yugoslavia	8100
7:30-8:00 p.m.	Budapest, Hungary (Radio Budapest)		11910, 9833	London, England	15310, 11930, 9825
7:30-8:00 p.m.	Prague, Czechoslovakia (Radio Prague)		9585, 6170, 6105, 6055	Tokyo, Japan	15310, 11930, 9825
7:30-8:30 p.m.	Warsaw, Poland (Radio Warsaw)		9525, 6025	Moscow, USSR	17825, 15235
7:55-8:45 p.m.	Montreal, Canada (Radio Canada)		15190 (CKCX), 11720 (CHOL)	1937, 11890, 11845, 11825, 11805, 11740, 11700, 9700, 9665	
8:00-8:30 p.m.	Sofia, Bulgaria (Sofa Calling)		9700	Rome, Italy	9575, 6010
8:00-9:30 p.m.	Stockholm, Sweden (Radio Sweden)		9620	Tokyo, Japan	15335, 11705
8:00-10:30 p.m.	Cape Haitien, Haiti (The Evangelistic Voice) - no broadcast on Wednesdays and Thursdays		15400, 9656, 8105	Prague, Czechoslovakia	9585, 6170, 6105, 6055
8:15-9:00 p.m.	Brazzaville, French Equatorial Africa (Radio Brazzaville)		11970, 9825	Warsaw, Poland	9525, 6025
8:30-10:15 p.m.	Berna, Switzerland (Switzerland Calling)		11865 (HER5), 9535 (HER4), 6185 (HER3)	Moscow, USSR	11890, 11845, 11825, 11805, 11740, 11700, 9665
9:00-9:20 p.m.	Oslo, Norway (Radio Norway) - on Sundays only		15175, 11735, 9540	Warsaw, Poland	9525, 6025
9:00-9:30 p.m.	Copenhagen, Denmark (The Voice of Denmark) - no English on Sundays		9520 (OZF)	Sofia, Bulgaria	9525, 6025
9:00-12:00 p.m.	Quito, Ecuador (HCJB - The Voice of the Andes) - no broadcast on Mondays		15115, 11915, 9745	Stockholm, Sweden	11970, 9625
9:25-9:45 p.m.	Rome, Italy (Italian Broadcasting and Television System)		9675, 6010	Cape Haitien, Haiti	11865 (HER5), 9535 (HER4), 6185 (HER3)
9:30-9:40 p.m.	Cologne, Germany (The Voice of Germany)		11795, 9640	Berna, Switzerland	15175, 11735, 9540
9:30-10:00 p.m.	Warsaw, Poland (Radio Warsaw)		9525, 6025	Oslo, Norway	15175, 11735, 9540
9:30-10:10 p.m.	Hilversum, Holland (Radio Netherlands)		11950, 9590	Copenhagen, Denmark	9520
9:30-11:00 p.m.	Hilversum, Holland (The Happy Station) - special program on Sundays only		11950, 9590	Moscow, USSR	11890, 11845, 11825, 11805, 11740, 11700, 9700, 9665
9:30-11:00 p.m.	Port-au-Prince, Haiti (Radio Haiti) - on Thursdays only		6192 (4VHW)	Rome, Italy	9575, 6010
9:45-10:00 p.m.	Brazzaville, French Equatorial Africa (Radio Brazzaville)		11970, 9625	Cologne, Germany	11795, 9640
9:55-10:35 p.m.	Montreal, Canada (Radio Canada)		11945 (CKNK), 9585 (CKLP)	Warsaw, Poland	9525, 6025
10:00-10:30 p.m.	Bucharest, Romania (Bucharest Calling)		11937, 9570	Hilversum, Holland	11950, 9590
10:00-11:00 p.m.	Prague, Czechoslovakia (Radio Prague)		9585, 6170, 6105, 6055	(not on Sundays)	
10:00-11:45 p.m.	Guatemala City, Guatemala (TGNA)		9638, 5952	Brazzaville, French Equatorial Africa	11970, 9625
10:15-11:00 p.m.	Madrid, Spain (The Voice of Spain)		9360, 6130	Montreal, Canada	11950, 9590
10:30-11:00 p.m.	Copenhagen, Denmark (The Voice of Denmark) - no English on Sundays		9520 (OZF)	Brazzaville, French Equatorial Africa	11970, 9625
11:00-11:30 p.m.	Budapest, Hungary (Radio Budapest)		11910, 9833	Moscow, USSR	11890, 11845, 11825, 11805, 11740, 11700, 9700, 9665
11:00-11:30 p.m.	Sofia, Bulgaria (Sofa Calling)		9700	Rome, Italy	9575, 6010
11:00-12:00 p.m.	San Jose, Costa Rica (TIFC - The Lighthouse of the Caribbean)		9647, 6037	Cologne, Germany	11795, 9640
11:15-12:00 p.m.	Berna, Switzerland (Switzerland Calling)		11865 (HER5), 9535 (HER4)	Warsaw, Poland	9525, 6025
11:15-12:00 p.m.	Madrid, Spain (The Voice of Spain)		9360, 6130	Oslo, Norway	15175, 11735, 9540
11:30-12:00 p.m.	Bucharest, Romania (Bucharest Calling)		11837, 9670	(Sundays only)	
12:00-12:30 a.m.	Stockholm, Sweden (Radio Sweden)		9620	Copenhagen, Denmark	9520
12:15-12:30 a.m.	Brazzaville, French Equatorial Africa (Radio Brazzaville)		11970	Moscow, USSR	11890, 11845, 11825, 11805, 11740, 11700, 9700, 9665
12:15-1:00 a.m.	Madrid, Spain (The Voice of Spain)		9360, 6130	Rome, Italy	9575, 6010
12:30-1:00 a.m.	Warsaw, Poland (Radio Warsaw)		9625, 6025	Cologne, Germany	11795, 9640

## CIRCUIT THEORY

### ANTENNA STAGE

The RF amplifier V1 provides the necessary gain and preselection required for high sensitivity and rejection of image frequencies. Individual antenna input coils are used for either a balanced or unbalanced input (depending on method of antenna connection).

The ANT TRIM control, adjustable from the front panel, acts as a compensating capacitor to permit matching of the input circuits to any antenna.

### MIXER STAGE

The use of a separate high-frequency oscillator, V3, results in a more stable receiver, particularly at the higher frequencies. The output signal from V1 is electronically mixed with the output of V3 in the mixer tube V2. V3 provides a signal 455 KC higher than the incoming signal on all frequency ranges.

### Q-MULTIPLIER AND BFO

The Q-Multiplier circuit (V4) serves as both BFO and Q-Multiplier in this receiver. Used as a BFO for CW and SSB operation, the circuit, which acts as an oscillator, is coupled to the IF stage (via stray coupling) and provides the signal necessary for producing a beat note, or for carrier reinsertion during SSB operation. When the SELECTIVITY control, comprising R26 and S4, is in the CW-SSB position during this operation, R26 is in its maximum position. The frequency of the signal is varied by means of C31, the BFO-Q-MULT FREQUENCY control. This adjusts the pitch during CW operation or clarity of speech during SSB operation. For Q-Multiplier operation, S4 is switched away from the CW-SSB position, thus connecting the circuit directly to the IF stage through a coupling capacitor C9. The circuit serves as a positive feedback device having a highly selective tuned circuit which acts as a narrow "gate" for IF frequencies. The width of this gate is adjusted by means of R26 which controls the gain of V4. The resultant narrow peak can be moved around in the IF pass-band by adjustment of C31. The selectivity thus becomes adjustable and, in addition, the portion of the signal which contains the least amount of adjacent signal interference can be selected.

### IF STAGES

Two stages of IF amplification, V5 and V6, provide sufficient gain and selectivity for good performance. For maximum selectivity, double-tuned transformers, T2, T3 and T4, are used for interstage coupling. High-Q permeability-tuned transformers improve performance and add to ease of tuning. R24 varies the gain of V6 and therefore acts as the IF GAIN control.

The S-meter is placed in the circuit in such a manner that readings increase with signal strength. R28, the ZERO ADJ control, is adjusted for zero current through the meter with no signal input. The S-meter is only accurate when the IF gain control is at maximum, nor does the meter function properly when AVC is off.

### DETECTOR, AVC, ANL, 1st AUDIO

One diode of V7 (pin 5) serves as both detector and AVC rectifier. The rectified AVC voltage is applied to RF stage V1 and IF stage V5 to keep the output level of the receiver constant regardless of input signal variations. In the MVC position of S6, the AVC is grounded and is not in operation. The other diode (pin 6) acts as an automatic noise limiter by cutting noise peaks (caused by auto ignition, etc.) during reception. Since this causes a slight reduction in fidelity, the circuit should only be used when necessary.

The rectified signal from the detector is fed to the grid of the triode section of V7 which acts as the 1st audio amplifier. Audio level is adjusted by means of R25, the AF GAIN control.

## AUDIO AMPLIFIER

V8 is employed in a conventional resistance-coupled audio amplifier which is connected to output transformer T5. Taps are provided on the secondary of the transformer for 4 or 8 ohm speakers. A standard phone jack, accessible from the front panel, permits the use of low impedance headphones when desired. Insertion of a plug in the jack automatically disconnects any speaker connected to the 8 ohm tap.

## RECTIFIER

V9 functions as a full-wave rectifier in a conventional power supply circuit. C26, R23 and C27 provide the necessary filtering. The primary of the AC power transformer is fused for safety. The tapped primary also permits the use of the receiver on low AC voltages (less than 100), voltage selection being effected by S3. In most cases however, the switch should be left in the 117V position.

## FUNCTION SWITCH

This switch determines the mode of operation. In all positions except OFF, AC power is applied to the primary of T1, thus powering the receiver. In REC AM, DC plate voltage is applied (through the external jumper plug and the switch) to V1, V2 and V3. All other tubes (except V4) receive DC plate voltage direct from the power supply. In the SEND position, plate voltage to V1, V2 and V3 is cut off. In the Q-MULT position, plate voltage is also applied to V4, in addition to all other tubes.

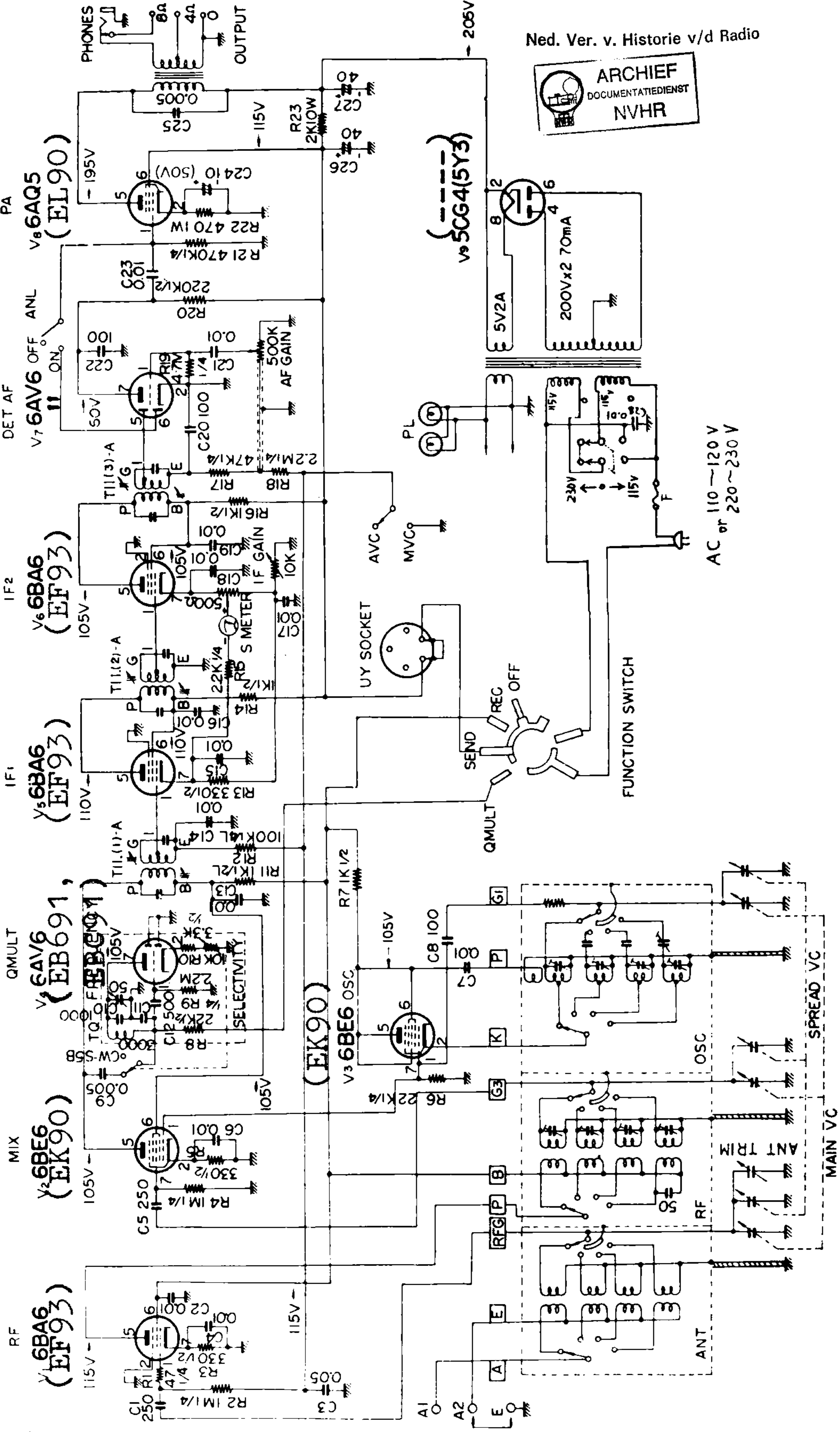
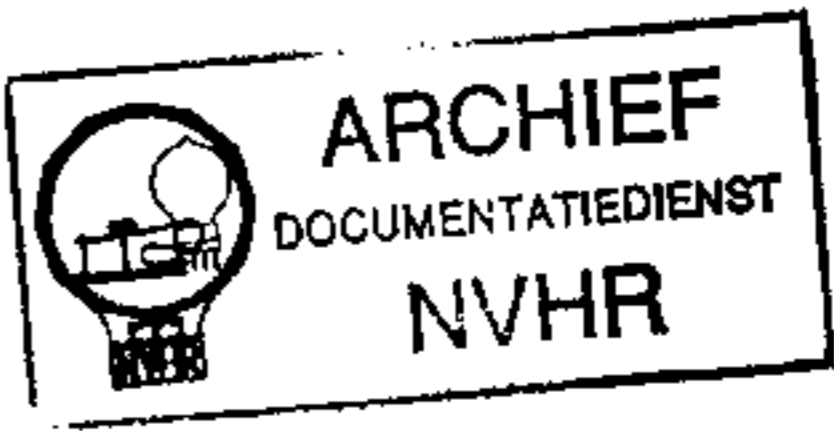

AC or 110 ~ 120 V  
220 ~ 230 V

## SERVICE

This section contains information which will aid qualified service personnel in the servicing and alignment of your receiver.

### CHASSIS REMOVAL

The top cover is held by four screws - two each side. The bottom cover is held by six screws on the underside of the unit.

### IF ALIGNMENT

#### EQUIPMENT REQUIRED:

AC Voltmeter  
Calibrated RF Signal Generator  
Non-Metallic Alignment Tool (GC No. 8722 or equiv.)

1. Connect a loudspeaker to the output terminals. Remove the local oscillator V3, 6BE6, from its socket.
2. Set the receiver controls as follows:
  - FUNCTION switch on REC AM
  - AF GAIN control to maximum
  - SELECTIVITY control on CW-SSB
  - IF GAIN control 3/4 full position
  - MVC - AVC switch on MVC
  - ANL off
3. Connect the voltmeter (3 volt AC range) across the speaker terminals.
4. Connect the signal generator between pin 7 of V2 socket (6BE6 mixer tube) and ground.
5. Set the signal generator at 455KC and modulate it with either 400 or 1000 cycles (30%).
6. Adjust the secondary and primary of IF transformers T4, T3 and T2 (see Fig. A). Follow the order given - secondary first, then primary in each case. Topside adjustments are secondaries, bottom of chassis adjustments are primaries.

During alignment, lower the generator output progressively to prevent overloading. Repeat alignment until no further improvement is noted.

### BFO AND Q-MULTIPLIER ADJUSTMENT

1. All receiver controls should be set as in the IF alignment with the exception of the following:
  - FUNCTION switch to Q-MULT
  - BFO-Q-MULT FREQUENCY to mid-position (white dot)
  - Reduce AF GAIN
2. Set the generator to 455KC, unmodulated RF.
3. Adjust the BFO coil T6 (located next to V4, Q-MULT) until a zero beat is heard (also accompanied by a peak reading on voltmeter).

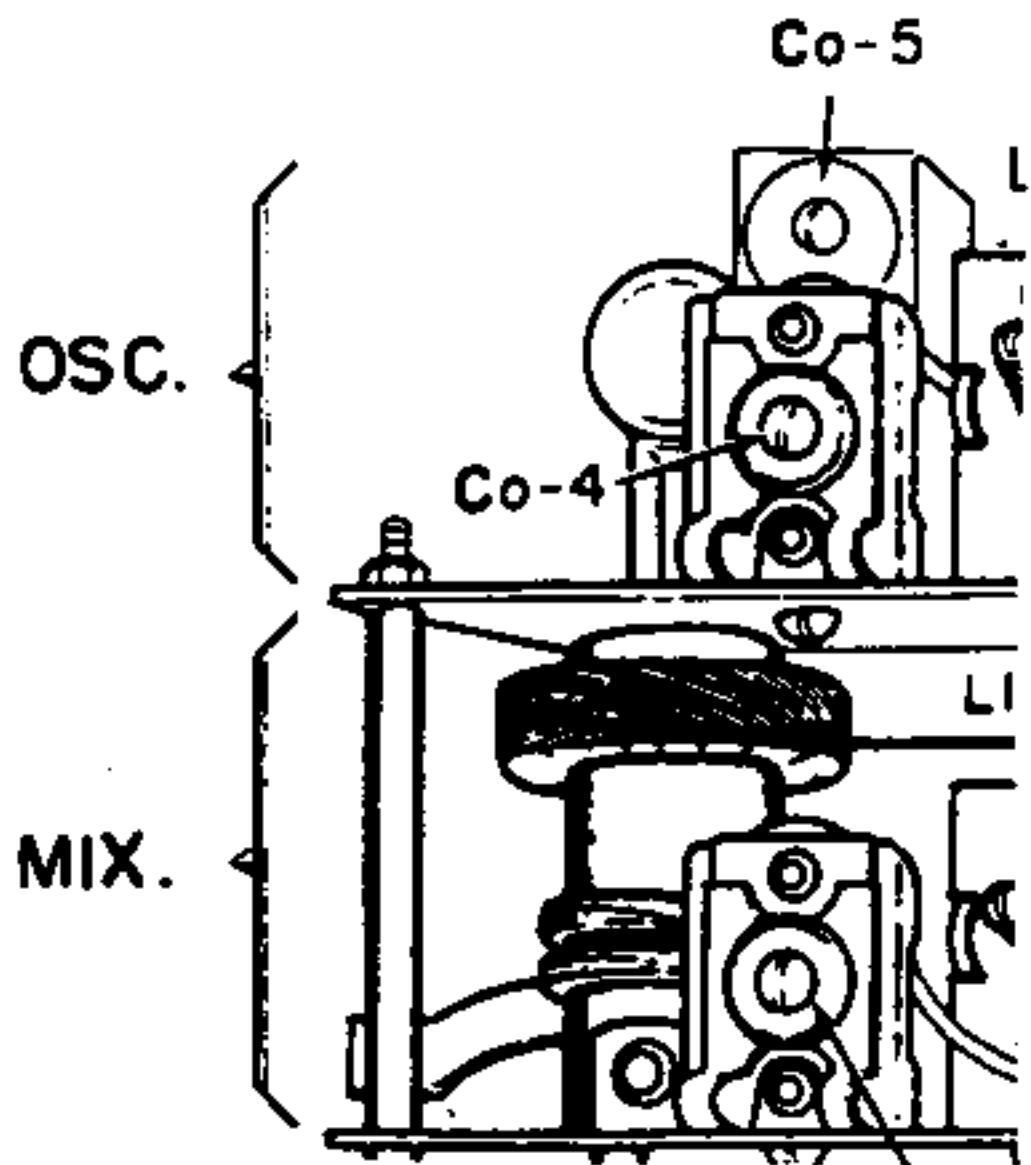

THESE TWO ADJUSTMENTS MADE WITH BOTTOM COVER REMOVED-REMAINDER OF RF ALIGNMENT CARRIED OUT WITH COVER IN PLACE

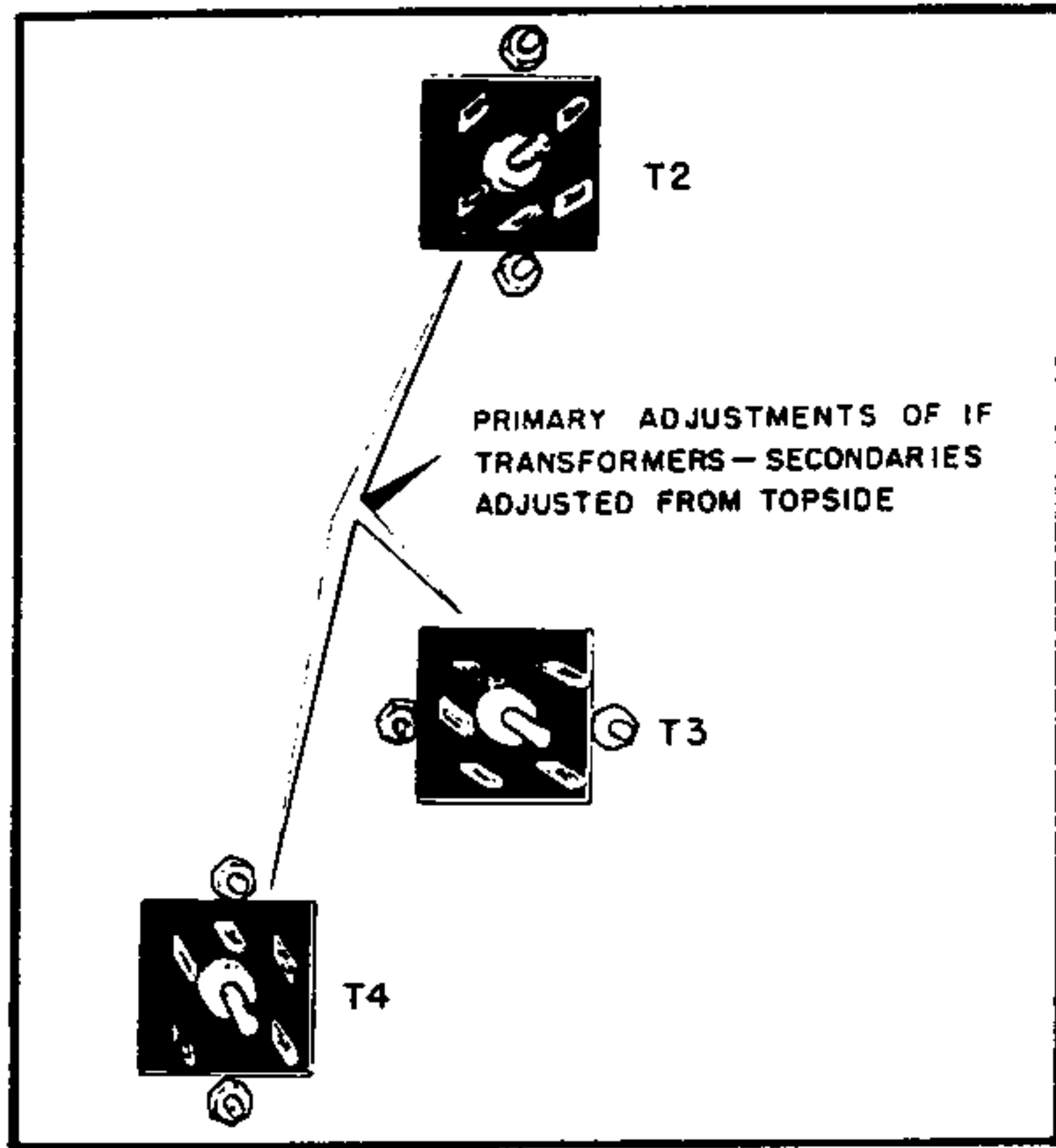
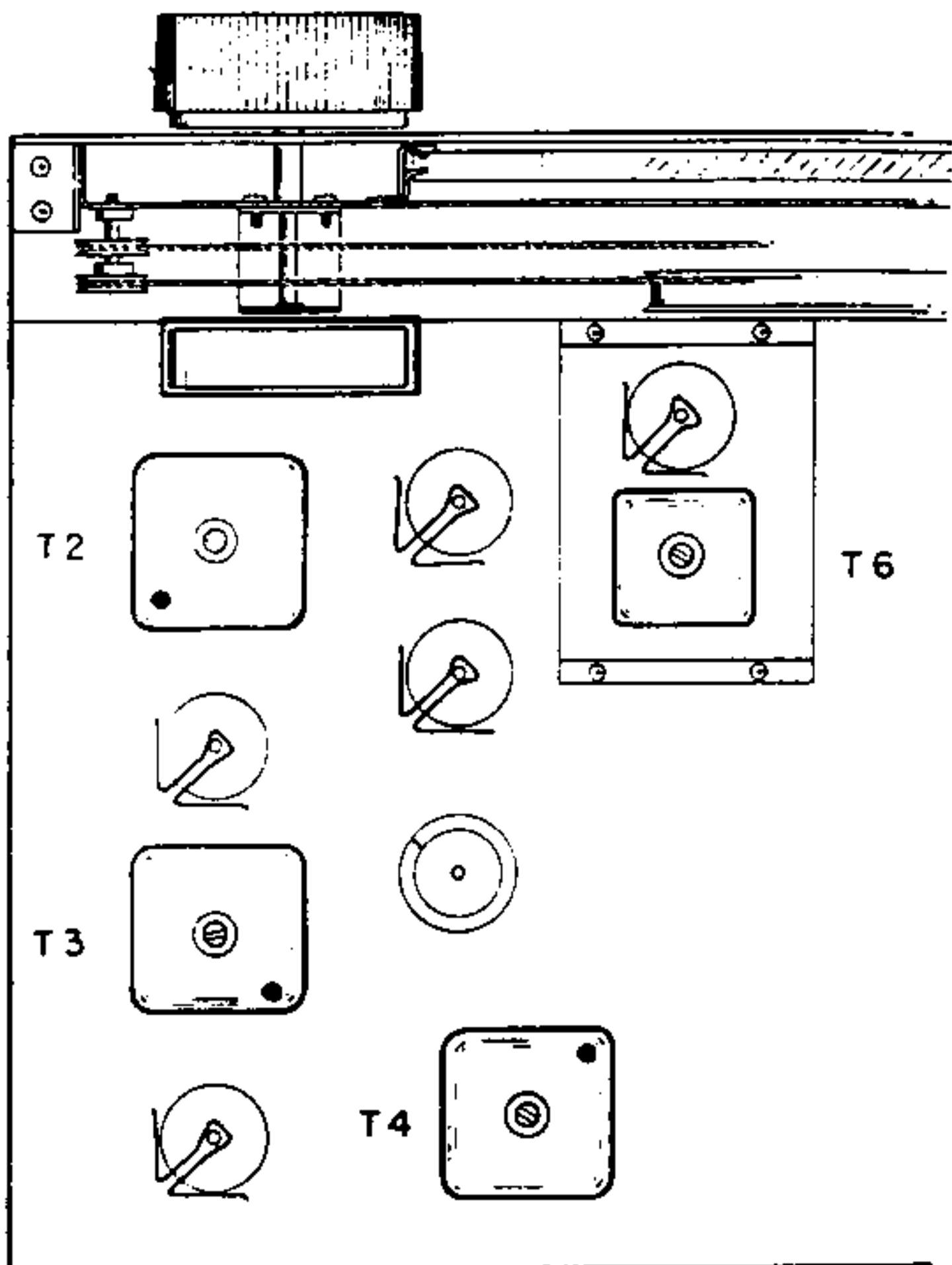

FIGURE A

## RF ALIGNMENT

1. Replace V3, 6BE6 local oscillator, in its socket.
  2. Using a short jumper wire, connect antenna terminals A2 and E together.
  3. Connect AC voltmeter (3 volt range) and loudspeaker across speaker terminals.
  4. Connect the modulated output of the RF signal generator to antenna terminals A1 and E.
  5. Rotate the ANT TRIM control until the capacitor plates are half-meshed. If the indicator dot on control knob is not at the 12 o'clock position, loosen set screw, place knob in this position and tighten screw again (without disturbing position of capacitor plates). Do not change control from the 12 o'clock position until alignment is completed.
  6. Set all receiver controls as for IF alignment. Set BANDSPREAD pointer at 100 on Logging Scale and make sure FUNCTION switch is on REC AM.
  7. Carry out alignment as indicated in the chart.
- Note: Lower generator output progressively to prevent overloading as circuits come into line.

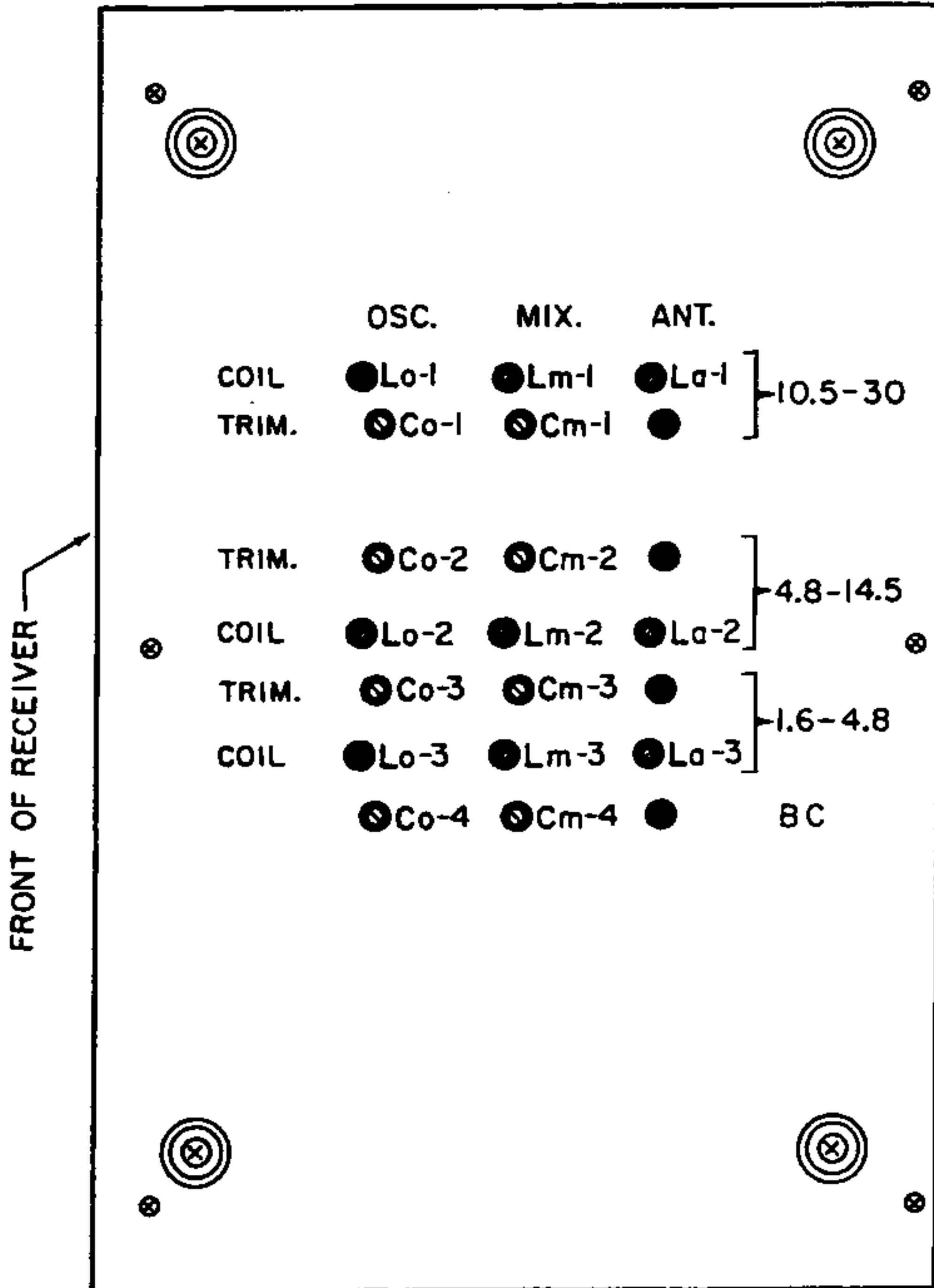

FIGURE B

LOCATION OF RF ADJUSTMENTS



## RF ALIGNMENT CHART

STEP	BAND SELECTOR	SIGNAL GENERATOR	MAIN TUNING	ADJUST	REMARKS	VIEW
1	.55-1.6	.6 MC (600KC)	.6 MC	Co-5 (Osc)	Adjust for peak reading on voltmeter	Figure A
2	.55-1.6	1.4 MC (1400KC)	1.4 MC	Co-4 (Osc)		
Repeat steps 1 & 2 until calibration is correct at both ends of scale (.6 and 1.4 MC). The remainder of the alignment must be carried out with the bottom cover in place. Remove power first.						
3	.55-1.6	1.4 MC (1400KC)	1.4 MC	Cm-4 (mixer)	Adjust for peak reading on voltmeter	
4	1.6-4.8	2.0 MC	2.0 MC	Lo-3 (Osc)		
5	1.6-4.8	4.0 MC	4.0 MC	Co-3 (Osc)		
Repeat steps 4 and 5 until calibration is correct at both ends of the scale (2.0 and 4.0 MC)						
6	1.6-4.8	2.0 MC	2.0 MC	Lm-3 (mixer)	Adjust for peak reading on voltmeter	
7	1.6-4.8	4.0 MC	4.0 MC	Cm-3 (mixer)		
Repeat steps 6 and 7 until calibration is correct at both ends of the scale (2.0 and 4.0 MC)						
8	1.6-4.8	2.0 MC	2.0 MC	La-3 (Ant)	Adjust for peak reading on voltmeter	Figure B
9	4.8-14.5	5.0 MC	5.0 MC	Lo-2 (Osc)		
10	4.8-14.5	14.0 MC	14.0 MC	Co-2 (Osc)		
Repeat steps 8 and 9 until calibration is correct at both ends of the scale (5.0 and 14.0 MC)						
11	4.8-14.5	5.0 MC	5.0 MC	Lm-2 (mixer)	Adjust for peak reading on voltmeter	
12	4.8-14.5	14.0 MC	14.0 MC	Cm-2 (mixer)		
Repeat steps 11 and 12 until calibration is correct at both ends of the scale (5.0 and 14.0 MC)						
13	4.8-14.5	5.0 MC	5.0 MC	La-2 (Ant)	Adjust for peak reading on voltmeter	
14	10.5-30	13.0 MC	13.0 MC	Lo-1 (Osc)		
15	10.5-30	28.0 MC	28.0 MC	Co-1 (Osc)		
Repeat steps 14 and 15 until calibration is correct at both ends of scale (13.0 and 28.0 MC)						
16	10.5-30	13.0 MC	13.0 MC	Lm-1 (mixer)	Adjust for peak reading on voltmeter	
17	10.5-30	28.0 MC	28.0 MC	Cm-1 (mixer)		
Repeat steps 16 and 17 until calibration is correct at both ends of scale (13.0 and 28.0 MC)						
18	10.5-30	13.0 MC	13.0 MC	La-1 (Ant)	Adjust for peak reading on voltmeter	

## VOLTAGE MEASUREMENTS

Voltages taken with receiver controls in the following positions

- BANDSPREAD pointer at 0 on Logging Scale
- MAIN TUNING pointer at 0 on Logging Scale
- FUNCTION switch on REC AM
- AF GAIN control fully counter-clockwise (minimum)
- SELECTIVITY control on CW-SSB
- BFO-Q-MULT FREQUENCY control on mid-position (white dot)
- BAND SEL on .55-1.6
- IF GAIN control fully counter-clockwise (minimum)
- MVC-AVC switch on AVC
- ANL switch on "off" position
- Short A1, A2 and E with jumper wire
- Voltage selector switch in 117 volt position

### SOCKET PIN NUMBERS

	1	2	3	4	5	6	7	8	9
RF									
V1 (6BA6)	0	0	6.3V AC	0	135	135	3.5	-	-
MIXER									
V2 (6BE6)	-7.7	3.6	6.3V AC	0	125	125	-	-	-
OSC									
V3 (6BE6)	-7.7	0	6.3V AC	0	125	125	125	-	-
Q-MULT									
V4 (6AV6)	**2.2 Meg	**3.3 K	6.3V AC	0	0	0	135	-	-
1st IF									
V5 (6BA6)	0	0	6.3V AC	0	135	135	19	-	-
2nd IF									
V6 (6BA6)	0	0	6.3V AC	0	135	135	19	-	-
Detector, ANL									
1st audio									
V7 (6AV6)	-.3	0	6.3V AC	0	-.06	-.08	70	-	-
Audio Output									
V8 (6AQ5)	0	7	6.3V AC	0	200	135	NC	-	-
Rectifier									
V9 (5Y3)	NC	205	NC	200	NC	200	NC	205	-

\* Place FUNCTION in Q-MULT position and remove V4 from socket. Check voltages from top of socket (numbering is now counter-clockwise)

\*\* Resistance measurements taken at these pins - REMOVE AC POWER FROM RECEIVER FIRST

1. Voltages taken with 20,000 ohms per volt meter and, unless otherwise noted, measured from chassis ground to joint indicated.
2. Line voltage maintained at 117V AC for these measurements.
3. Tolerance on components permits a variation of  $\pm 15\%$  in readings.
4. All voltages DC unless otherwise noted.

## DIAL CORD STRINGING

Set main or bandspread tuning capacitor as indicated. In both cases, tie dial cord to spring at the **START** point, leaving approximately 4 inches of cord free at this point. Restring in the direction indicated, keeping a moderate amount of tension on the cord. Make final tie to free end of cord from spring after cutting off any excess cord.

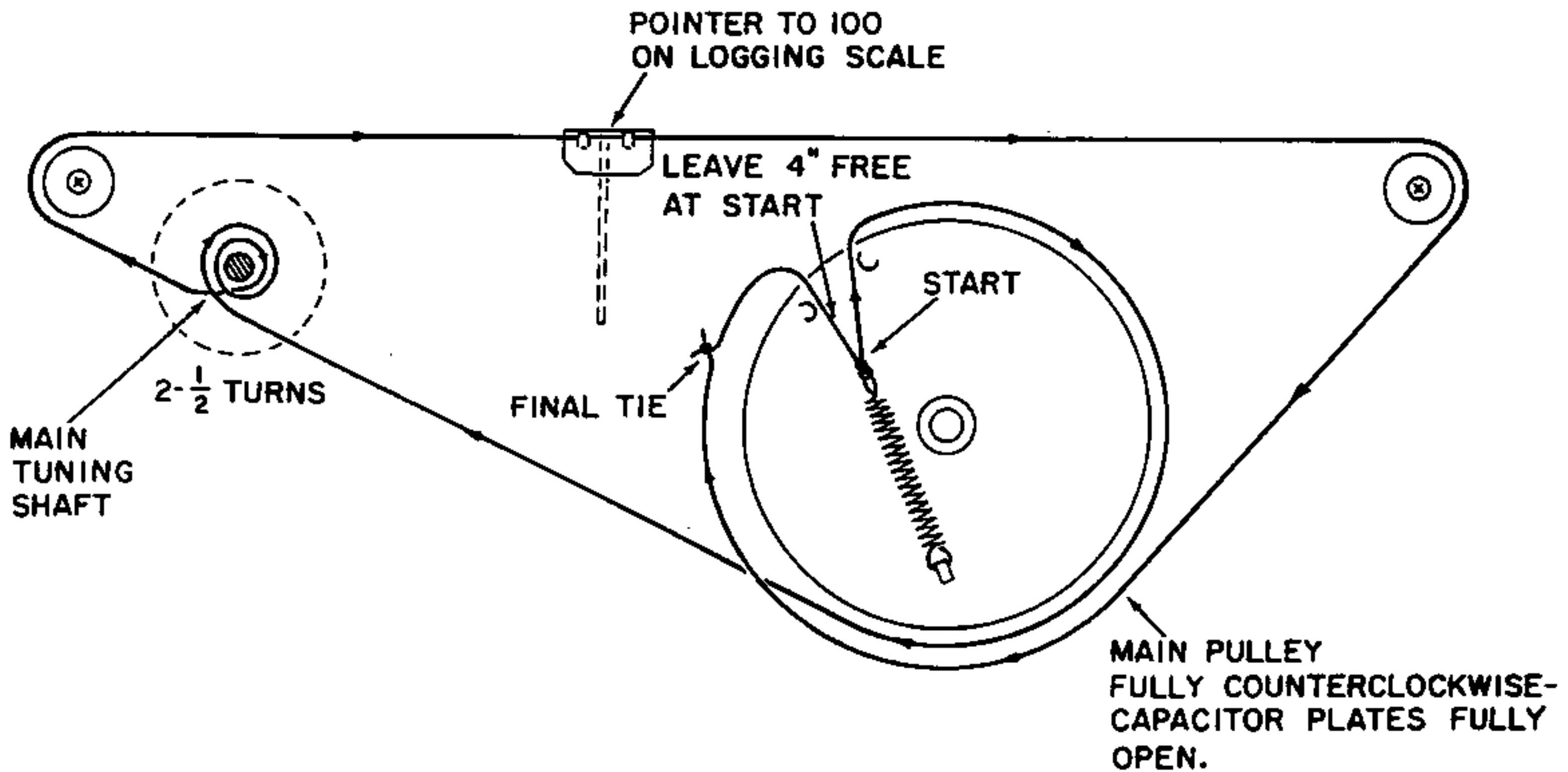

MAIN TUNING DIAL CORD STRINGING

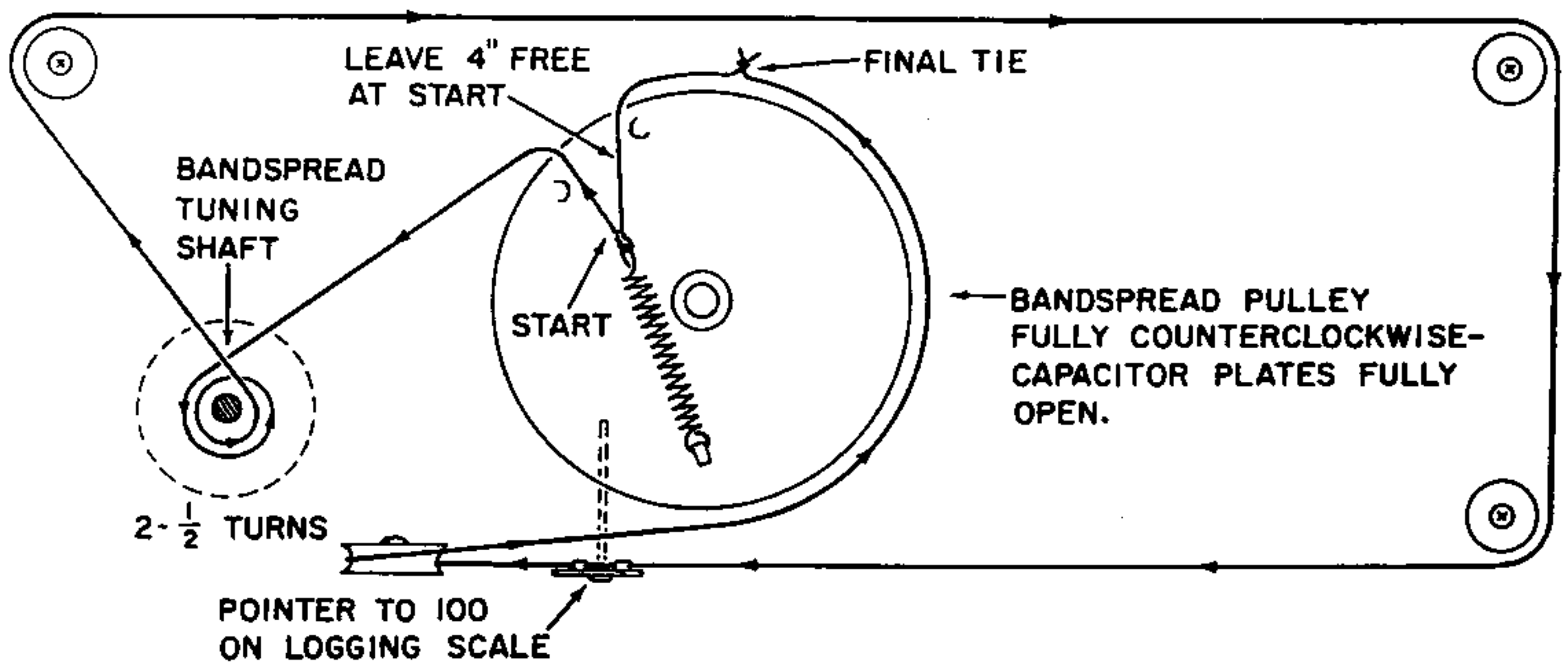

BANDSPREAD DIAL CORD STRINGING

## PARTS LIST

CIRCUIT DESIGNATION	DESCRIPTION	QUANTITY	PART NO.
<b>CAPACITORS</b>			
C1, C5	250 mmfd, mica	2	30-100
C2, C4, C6, C7, C13, C14, C15, C16, C17, C18, C19	0.01 mfd, disc	11	30-101
C3	0.05 mfd, tubular	1	30-102
C8, C20, C22	100 mmfd, mica	3	30-103
C9	0.005 mfd, disc	1	30-104
C10	0.001 mfd, mica	1	30-105
C11	0.003 mfd, mica	1	30-106
C12	500 mmfd, mica	1	30-107
C21, C23, C28	0.01 mfd, tubular	3	30-108
C24	10 mfd, electrolytic	1	30-109
C25	0.005 mfd, tubular	1	30-110
C26, C27	40-40. mfd, 300 volt electrolytic	1	30-111
C29A	Main Tuning Capacitor	1	30-112
C29B	Band Spread Tuning Capacitor	1	30-113
C30	Antenna Trimmer	1	30-114
C31	50 mmfd, variable capacitor (BFO)	1	30-115

### RESISTORS

R1	47 ohm, 1/4 watt	1	30-116
R2, R4	1 M (meg) ohm, 1/4 watt	2	30-117
R3, R5, R13	330 ohm, 1/2 watt	3	30-118
R6	22 K(kil) ohm, 1/4 watt	1	30-119
R7, R11, R14, R16	1 K ohm, 1/2 watt	4	30-120
R8	22 K ohm, 1/2 watt	1	30-121
R9, R18	2.2 M ohm, 1/4 watt	2	30-122
R10	3.3 K ohm, 1/2 watt	1	30-123
R12	100 K ohm, 1/4 watt	1	30-124
R15	2.2 K ohm, 1/4 watt	1	30-125
R17	47 K ohm, 1/4 watt	1	30-126
R19	4.7 M ohm, 1/4 watt	1	30-127
R20	220 K ohm, 1/2 watt	1	30-128
R21	470 K ohm, 1/4 watt	1	30-129
R22	470 ohm, 1 watt	1	30-130
R23	2 K ohm, 10 watts	1	30-131
R24	10 K ohm, IF Gain Control	1	30-132
R25	500 K ohm, Audio Gain Control	1	30-133
R26	10 K ohm, Selectivity Control	1	30-134
R27	30 ohm, 1/4 watt	1	30-135
R28	500 ohm, S-meter Zero Adjust	1	30-136

### TUBES

V1, V5, V6	6BA6	3	30-137
V2, V3	6BE6	2	30-138
V4, V7	6AV6	2	30-139
V8	6AQ5	1	30-140
V9	5Y3	1	30-141
PL	#40 light bulb	2	30-142

CIRCUIT DESIGNATION	DESCRIPTION	QUANTITY	PART NO.
<b>SWITCHES</b>			
S1	FUNCTION Switch	1	30-156
S2	BAND SEL Switch	1	30-157
S3	SPDT Input Voltage Selector	1	30-158
S4	CW-SSB Switch (On R26)	1	30-159
S5	SPST ANL OFF - ON Switch	1	30-160
S6	SPST MVC - AVC Switch	1	30-161
<b>TRANSFORMERS, AND COILS</b>			
T1	Power Transformer	1	30-162
T2, T3, T4	IF Transformer (455 KC)	3	30-163
T5	Output Transformer	1	30-164
T6	Q-MULTIPLIER Coil	1	30-165
<b>MISCELLANEOUS</b>			
M1	S-Meter	1	30-167
J1	Antenna Input Jack	1	30-168
J2	Earphone Jack	1	30-169
J3	External Control Jack	1	30-170
P1	External Control Plug	1	30-171
	Dial Pointer	1	30-172
	Small Knobs	6	30-173
	Large Tuning Knobs	2	30-174
	Antenna Trimmer Knob	1	30-175
	Fuse Holder	1	30-176
	Q-Multiplier Assembly Chassis	1	30-177
	Glass Dial Plate	1	30-178
	Fly Wheels	2	30-179
	Pilot Light Assembly	1	30-180
	Top Cabinet Cover	1	30-181
	7-Pin Miniature Socket	8	30-182
	Octal Socket	1	30-183
	Bottom Cabinet Cover	1	30-184
	Main Chassis	1	30-185
<b>RF ASSEMBLY</b>			
	.55 - 1.6 MC Antenna Coil, Non-adjustable (located in ANT section)	1	30-189
La-3	1.6 - 4.8 MC Antenna Coil, Adjustable	1	30-190
La-2	4.8 - 14.5 MC Antenna Coil, Adjustable	1	30-191
La-1	10.5 - 30 MC Antenna Coil, Adjustable	1	30-192
	.55 - 1.6 Mixer Coil, Non-adjustable (located in the MIXER section)	1	30-193
Lm-3	1.6 - 4.8 MC Mixer Coil, Adjustable	1	30-194
Lm-2	4.8 - 14.5 MC Mixer Coil, Adjustable	1	30-195
Lm-1	10.5 - 30 MC Mixer Coil, Adjustable	1	30-196
	.55 - 1.6 MC Oscillator Coil, Non-adjustable (located in the OSCILLATOR section)	1	30-197
Lo-3	1.6 - 4.8 MC Oscillator Coil, Adjustable	1	30-198
Lo-2	4.8 - 14.5 MC Oscillator Coil, Adjustable	1	30-199
Lo-1	10.5 - 30 MC Oscillator Coil, Adjustable	1	30-200
Cm-4	.55 - 1.6 MC Mixer Trimmer Capacitor	1	30-201
Cm-3	1.6 - 4.8 MC Mixer Trimmer Capacitor	1	30-202
Cm-2	4.8 - 14.5 MC Mixer Trimmer Capacitor	1	30-203
Cm-1	10.5 - 30 MC Mixer Trimmer Capacitor	1	30-204
Co-4	.55 - 1.6 MC Oscillator Trimmer Capacitor	1	30-205
Co-3	1.6 - 4.8 MC Oscillator Trimmer Capacitor	1	30-206
Co-2	4.8 - 14.5 MC Oscillator Trimmer Capacitor	1	30-207
Co-1	10.5 - 30 MC Oscillator Trimmer Capacitor	1	30-208