

K-B**Model FP151**

General Description : Four-valve, two-waveband portable super-heterodyne receiver for operation from batteries or A.C./D.C. mains. Weight 6½ lb. Released January 1951.

Power Supplies : A.C./D.C. mains, 200–250 volts. Consumption 15 watts D.C., 20 watts A.C.

Batteries : H.T. (90-volt) types Ever Ready B126, Drydex 4526, Vidor L5512. Nominal life 60 hours. L.T. (7.5-volt) types Ever Ready All-dry 31, Drydex H1177, Vidor L5042. Nominal life 100 hours.

Wavebands : L.W. 2150–910 m. (140–330 kc/s.); M.W. 186–560 m. (1610–535 kc/s.).

Undistorted Output : 90 mW.

Intermediate Frequency : 422 kc/s.

Valves : Brimar. (V1) 1R5; (V2) 1T4; (V3) 1U5; (V4) 3V4. Two RM3 rectifiers.

Alignment Procedure : Operations must be carried out in the order indicated.

Operation	Circuits	Signal Generator Connection	Input Signal	Set Pointer to	Adjust for Maximum Response
1	I.F.	Grid of V1 via 0.1- μ F. capacitor	422 kc/s.	1610 kc/s.	L10, L9, L3 and L4
2	M.W.	Aerial socket via dummy aerial	600 kc/s.	500-m. line	L7
3	—	—	1500 kc/s.	200-m. line	T2 and T1
4*	L.W.	—	175 kc/s.	1714-m. line	L5 and L2

* A 1-pF. capacitor should be connected across L2 during operation No. 4.

Notes : The tuning pointer should be set to the datum mark with the gang fully enmeshed before alignment. Repeat operations 2 and 3 until scale accuracy and maximum sensitivity have been attained. Progressively reduce signal input as sensitivity increases.

Voltage Chart : Following readings, which should be regarded as approximate, were taken with band switch in M.W. position and volume control at minimum gain. Mains input 225 volts with voltage adjustment set to 225 volts. Total H.T. current: 9.2 mA. (battery), 10.2 mA. (mains).

Valve	Power	Voltage between Socket and Chassis							
		Pin 1	2	3	4	5	6	7	8
V1	Battery	—	86	29	—	—	—	1.5	—
	Mains	—	92	34	—	—	—	1.3	—
V2	Battery	2.85	86	36	—	2.85	—	4.4	—
	Mains	2.5	92	40	—	2.5	—	3.9	—
V3	Battery	1.5	4	—	—	—	—	2.85	—
	Mains	1.3	5	—	—	—	—	2.5	—
V4	Battery	4.45	80	86	—	6	—	7.5	—
	Mains	6.4	87	92	—	7.6	—	8.75	—

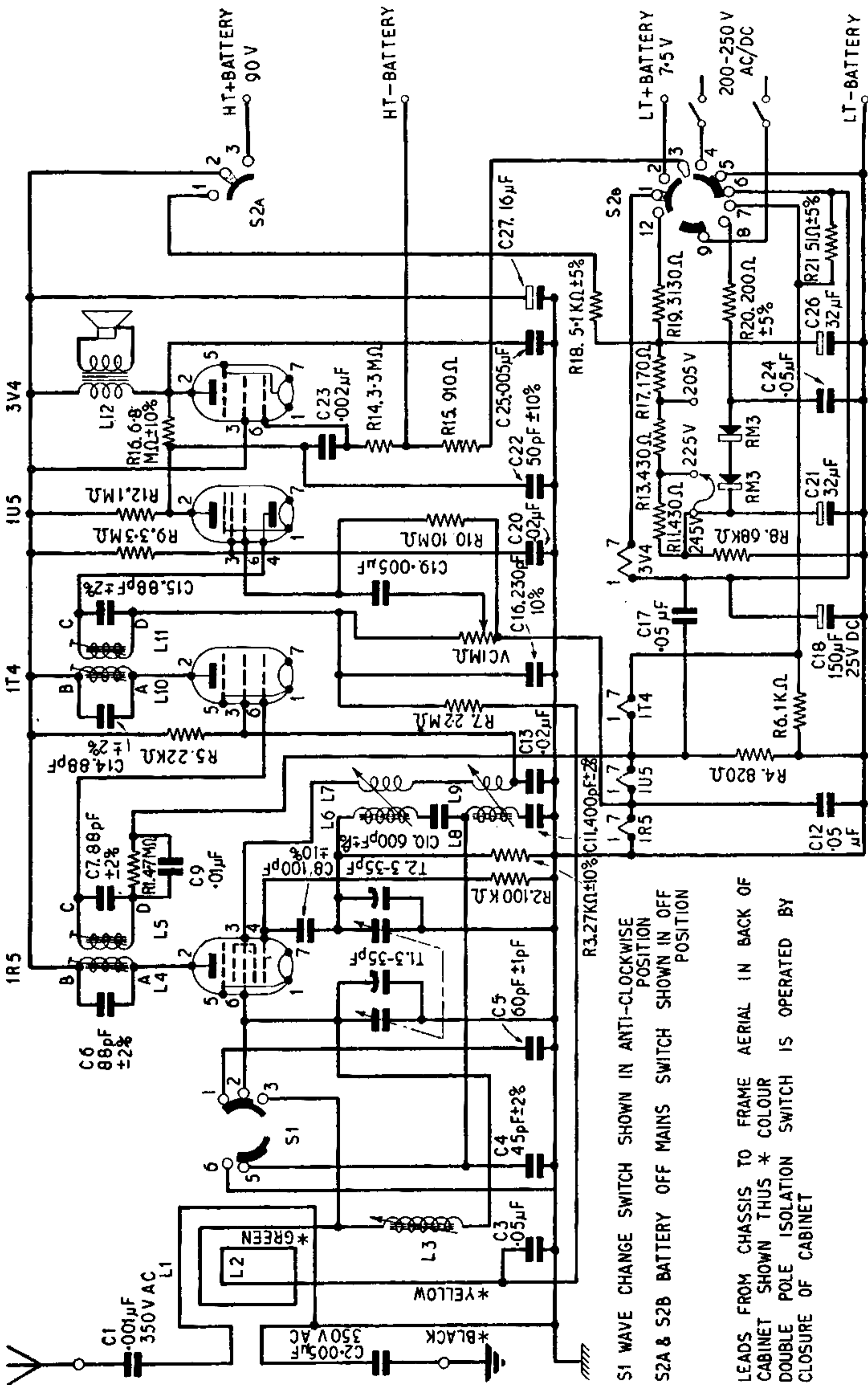

S1 WAVE CHANGE SWITCH SHOWN IN ANTI-CLOCKWISE POSITION

S2A & S2B BATTERY OFF MAINS SWITCH SHOWN IN OFF POSITION

LEADS FROM CHASSIS TO FRAME AERIAL IN BACK OF CABINET SHOWN THUS * COLOUR

DOUBLE POLE ISOLATION SWITCH IS OPERATED BY CLOSURE OF CABINET

CIRCUIT DIAGRAM—K-B MODEL FPI 51