

"TRADER" SERVICE SHEET
539

MARCONI 255 & 255MC HMV 459 & 459MC

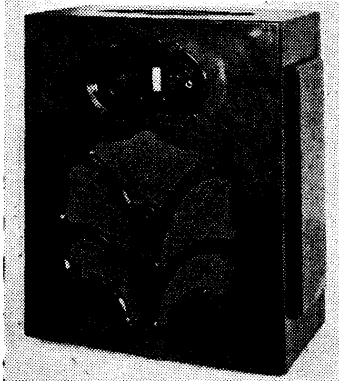

The Marconiphone 255 and 255MC.

THE first part of this *Service Sheet* deals exclusively with the Marconiphone model 255 receiver, whose speaker is of the moving-iron (cone) type. The receiver is a 6-valve, 2-band portable superhet, using a separate triode valve as an oscillator. Mixing is accomplished via an oscillator pick-up coil. A local/distant control is fitted.

The second part covers the differences in a later receiver, model 255MC, in which a moving coil speaker is employed. The external and internal appearance of the two models is similar except for the local/distant switch and speaker adjustment screw, which are omitted from the MC model.

Two similar receivers (except for the external appearance) are the HMV 459 cone and 459MC, and all four models are covered in this Service Sheet, which was prepared from Marconiphone receivers.

Release dates: *Cone models*, 1932; *MC models*, 1933.

CIRCUIT DESCRIPTION

Tuned frame aerial input L1 (MW), plus L2 (LW), and C18 precedes an RF tetrode valve (V1, Marconi metallised S21) which operates as signal frequency amplifier, with anode circuit tuning by L3 (MW), plus L4 (LW), and C21. C17 permits fine manual trimming of the frame aerial circuit, independently of the gang condenser. Its control is concentric with that of the gang. Provision is made for connection of an external aerial via series condenser C1, and for an earth connection.

Second valve (V2, Marconi metallised HL2) is a triode operating as local oscillator. Anode coils L7 (MW), plus L8 (LW), are tuned by C23. Parallel trimming by C24 (MW) and C4, via S4 and C2, (LW); tracking is achieved by suitably shaped plates of C23. Reaction coupling from grid circuit by coil L6.

The tuned RF output from V1 anode circuit is conveyed via the mixer coil L5, which is inductively coupled with the oscillator circuit and thus picks up the oscillator frequency, via the isolating condenser C5 to the control grid circuit of a second RF tetrode valve (V3, Marconi metallised S21) which operates as a mixer.

Fourth valve (V4, Marconi metallised S21) is a third RF tetrode, operating this time as intermediate frequency amplifier. Coupling between V3 and V4 is via the transformer L9, L10, whose primary and secondary circuits are tuned by condensers C7 and C8, C25 respectively to the intermediate frequency. V4 anode circuit is tuned to the intermediate frequency by L11, C10, C26.

Intermediate frequency 125 KC/S.

IF output from V4 is passed via C11 to control grid circuit of a second triode

valve (V5, Marconi metallised HL2) which operates as second detector on the grid leak system with R5, C11. IF filtering by C12 in anode circuit. Provision for connection of gramophone pick-up in control grid circuit.

In order to prevent overloading in the output circuit when receiving strong signals, a local/distant switch S5 is provided. Normally, it is left open, but when it is closed for "Local," R6 is connected across the control grid circuit and damps it, thus reducing its sensitivity.

Audio frequency output from V5 is transformer coupled via T1 to control grid circuit of pentode output valve (V6, Marconi PT2). Fixed tone correction by C15 in anode circuit. Provision for connection of high impedance external speaker by the terminals to which the internal speaker is connected. In the case of either speaker, it is important that the positive lead should go to the appropriate terminal, which is marked "+" on the chassis.

Gain control potential for V1 and V3, which are operated like variable-mu valves in this receiver, is obtained via decoupling circuits from the slider of the volume control potentiometer R10, which is included in the negative HT lead to chassis. GB potential for V6 is obtained from a fixed tapping on R10.

VALVE ANALYSIS

Valve voltages and currents given in the table, col. 4, have been taken from the makers' manual. They represent approximately the condition when the HT positive plug is inserted in the 108-volt tapping of a new HT battery of the recommended type, with the volume control at maximum and S5 at "distant."

Voltages were measured on the 120 V

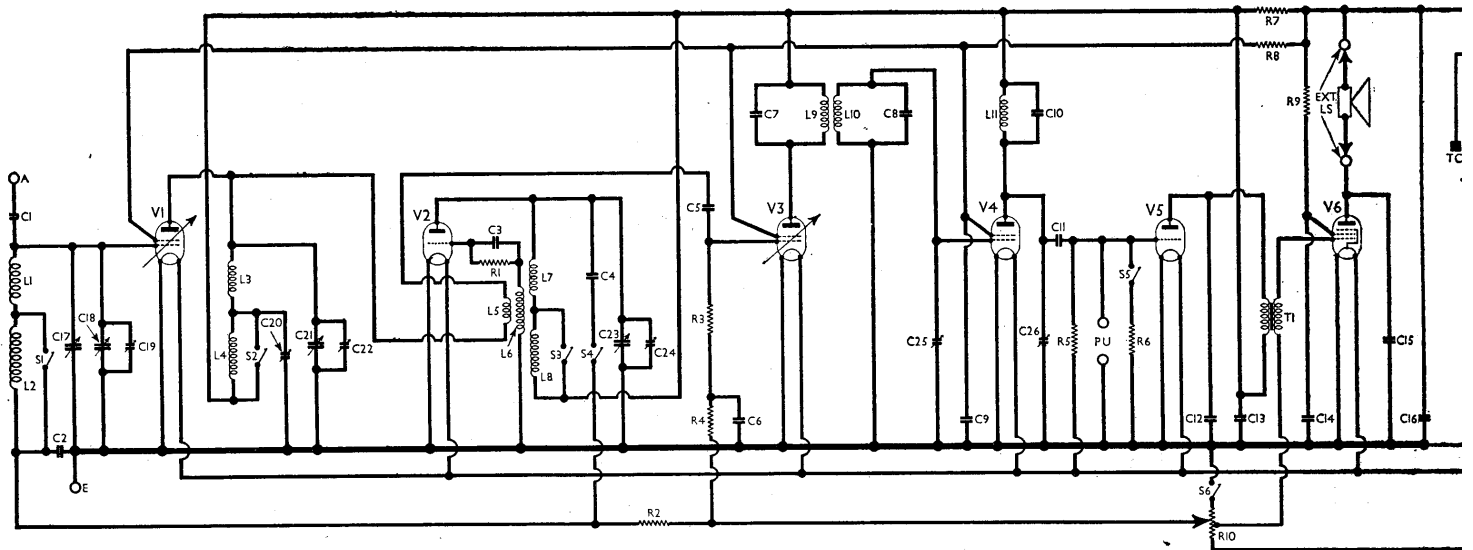

scale of a Universal Avometer, chassis being negative.

Valve	Anode Voltage (V)	Anode Current (mA)	Screen Voltage (V)	Screen Current (mA)
V1 S21	62	1.2	40	1.0
V2 HL2	62	1.5	—	—
V3 S21	62	0.6	40	0.4
V4 S21	62	1.4	40	1.2
V5 HL2	60	2.3	—	—
V6 PT2	90	3.0	80	—

COMPONENTS AND VALUES

RESISTANCES		Values (ohms)
R1	V2 CG resistance ...	50,000
R2	V1 CG decoupling ...	1,000,000
R3	V3 CG resistance ...	1,000,000
R4	V3 CG decoupling ...	1,000,000
R5	V5 CG resistance ...	1,000,000
R6	Local/distant damping ...	2,000
R7	V1-V5 anode HT feed ...	10,000
R8	V1, V3, V4 SG HT feed ...	20,000
R9	V6 SG HT feed ...	5,000
R10	Gain control ...	600*

* Tapped at 250 O from HT negative end.

CONDENSERS		Values (μF)
C1	Aerial series condenser ...	0.00005
C2	V1 CG decoupling ...	0.5
C3	V2 CG condenser ...	0.0002
C4	Osc. circ. LW trimmer ...	0.0002
C5	V3 CG condenser ...	0.0001
C6	V3 CG decoupling ...	0.1
C7	IF transformer fixed tuning condensers ...	0.0005
C8	V1, V3, V4 SG's by-pass ...	0.1
C9	V4 anode fixed tuning ...	0.0003
C10	V4 to V5 IF coupling ...	0.0001
C11	IF by-pass ...	0.0005
C12	V1-V5 anodes by-pass ...	0.5
C13	V6 SG by-pass ...	0.1
C14	Fixed tone corrector ...	0.007*
C15	HT reservoir condenser ...	2.0
C16	Frame manual trimmer ...	0.0001
C17	Frame aerial tuning ...	—
C18	Frame aerial MW trimmer ...	—
C19	V1 anode LW trimmer ...	0.0001
C20	V1 anode circuit tuning ...	—
C21	V1 anode MW trimmer ...	—
C22	Oscillator circuit tuning ...	—
C23	Osc. circuit MW trimmer ...	—
C24	IF trans. sec. trimmer ...	0.0003
C25	V4 anode IF trimmer ...	0.0003

■ † Variable. ‡ Pre-set. *Made up of 0.002 μF and 0.005 μF condensers connected in parallel.

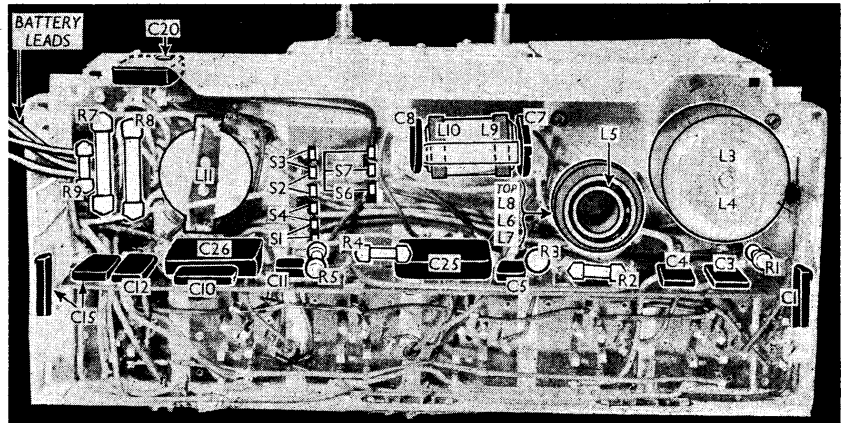
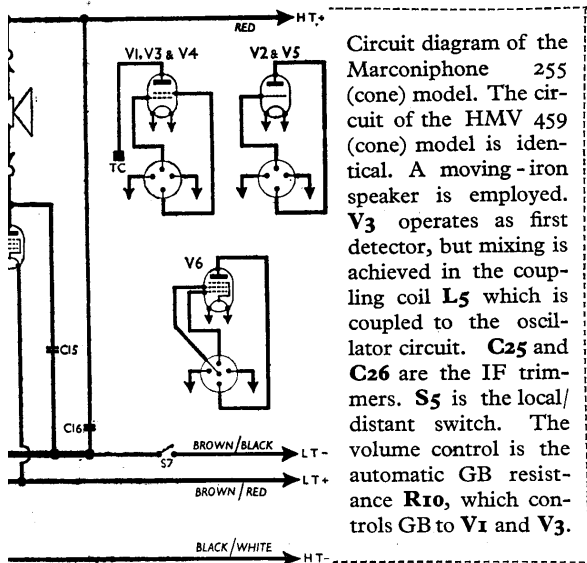

Under-chassis view of the cone models. The switch unit is on the chassis deck, but the tags of the switches are indicated here.

OTHER COMPONENTS		Approx. Values (ohms)
L1	Frame aerial windings ...	2.0
L2	Frame aerial windings ...	16.0
L3	V1 anode circuit tuning coils ...	4.0
L4	V1 anode circuit tuning coils ...	13.0
L5	Mixer coupling coil ...	2.5
L6	Oscillator reaction coil ...	2.4
L7	Osc. circ. MW tuning coil ...	4.0
L8	Osc. circ. LW tuning coil ...	6.0
L9	IF trans. Pri. ...	25.0
L10	IF trans. Sec. ...	25.0
L11	V1 anode IF coil ...	25.0
T1	Intervalve Pri. trans. ...	500.0
	Intervalve Sec. trans. ...	5,000.0
LS	Speaker winding ...	1,900.0
S1-S4	Waveband switches ...	—
S5	Local/distant switch ...	—
S6	HT circuit switch ...	—
S7	LW circuit switch ...	—

DISMANTLING THE SET

Removing Chassis.—Remove the cleat (small wood screw) holding the frame aerial leads to the side of the case; remove the three small screws holding the frame aerial connecting panel to the lower chassis deck; or, alternatively, unsolder the four leads; disconnect from the Extra LS terminals at rear of chassis the speaker leads; remove the four cheese-head screws (with washers and lock-washers) holding the chassis to the metal brackets at the sides of the case.

To obtain access to the underside of the chassis, remove the metal screening plate (four self-tapping screws).

When replacing, connect speaker leads to the appropriate terminals, the red lead going to the one marked “+.”

If the frame aerial leads have been unsoldered, reconnect them as follows, numbering the tags on the connecting panel from front to rear of chassis :

- 1, maroon lead from MW frame in front of case;
- 2, two green leads with yellow tracer, one from each frame;
- 3, maroon from LW frame in back cover.

GENERAL NOTES

Switches.—S1-S4 are the waveband switches, and S6, S7 the battery circuit switches, in a three-position rotary unit on the chassis deck. This is indicated in our plan view, but the connecting tags to the switch contacts are indicated in our

under-chassis view, where the individual switch connections are indicated. S1, S2 and S3 close on MW, and open on LW; S4 opens on MW, and closes on LW; S6, S7 close on MW and LW, and open only in the “Off” position of the control.

S5 is the QMB local/distant control, mounted with its associated damping resistance R6 under the pick-up terminals at the rear of the chassis.

Coils.—L1, L2 are the frame aerial windings. L1 is the MW winding, on a large frame mounted at the front of the carrying case; L2 is the LW winding, on a smaller frame mounted in the hinged back. They are connected to three tags at one corner of the rear of the chassis, the connections being described under “Dismantling the Set.”

L3, L4 are V1 anode tuning coils, under a screening can beneath the chassis. The mixing coil L5 and the oscillator coils L6-L8 are in an unscreened unit near L3, L4. L5 is on a separate former inside the L6-L8 former.

The IF transformer L9, L10 is an unscreened unit mounted on a metal bracket with its fixed tuning condensers C7, C8 beneath the chassis. The secondary trimmer C25 is mounted on a step in the chassis just behind it, and its adjusting screw faces the rear, between V3 and V4 holders. The single tuned IF coil L11 is mounted beneath the chassis, just in front of V2 holder. Its fixed tuning condenser C10 and trimmer C26 are mounted on the step near it, like C25.

Condenser C17.—This is a small variable condenser of the solid dielectric type connected in parallel with the C18 section of the gang. Its control spindle is concentric with that of the gang, and it permits final manual trimming of the aerial circuit.

Condenser Block.—This is an assembly of six decoupling and by-pass condensers, in a metal-cased unit on the chassis deck. The colour coding of the connecting leads is as follows: C2, maroon; C6, green; C9, yellow with red tracer; C13, yellow; C14, yellow with black tracer; C16, red. These leads represent one side of each of the condensers in the block; the other side of each is taken to a common black lead, which goes to chassis.

R10.—This is the gain control potentiometer, which has four connecting tags.

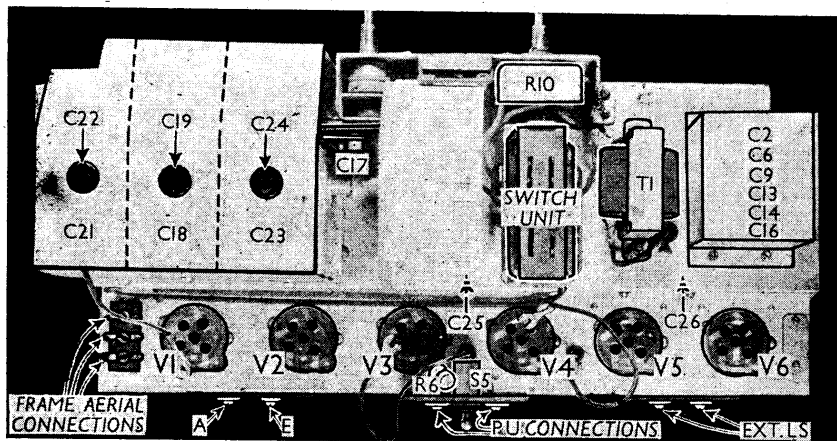

Plan view of the chassis of the cone models. That of the moving coil models is the same except for the following: **T1** is encased in a square container; only four condensers (**C2, C5, C12, C13**), instead of six, are contained in the condenser block; and **C19** and **R6, S5** are omitted altogether. **R10** becomes **R3**.

One, the slider, is mounted on the rotor, and must be connected by a flexible lead, which must be turned in a loop round the switch spindle to reduce the twisting effect. The two stator connections are the two outer tags of the three at the top of the control; the centre tag, connected to the casing, has no connection. The fixed tapping is the tag at the bottom.

Gramophone Pick-up.—Two terminals are provided at the rear of the chassis for the connection of a gramophone pick-up. An external volume control is required for the pick-up, which must be disconnected when it is desired to revert to radio operation.

External Speaker.—Two terminals at the rear of the chassis are marked "Extra LS + " and are provided for the connection of a high-impedance (about 15,000-20,000 Ω) external speaker. The internal speaker leads are connected to the same terminals. The red lead should go to the terminal marked "+."

Batteries.—The batteries recommended by the makers are: HT, Marconiphone type B574, 129 V over all, including 4.5 V GB. No GB tapping is used; GB is obtained automatically. LT, Exide type 2AN7-4 unspillable, with jelly electrolyte.

Battery Leads and Voltages.—Black/white lead, black plug, HT negative (or GB negative); red lead and plug, HT positive. Brown leads: with black tracer, LT negative; with red tracer, LT positive 2 V. The accumulator should be inserted in the case always with the red terminal to the right, otherwise instability may occur.

Chassis Divergency.—An additional 500,000 Ω resistance may be found connected in series with the lead to **V6** control grid in some chassis.

CIRCUIT ALIGNMENT

IF Stages.—Connect signal generator via a 0.1 μF condenser to control grid of **V3** and chassis, turn gain control to maximum, and switch **S5** to distant. Feed in a 125 KC/S (2,400 m) signal, and adjust **C26** and **C25** for maximum output.

RF and Oscillator Stages.—With the two scale indicators set to the centre of

their adjusting slots, the scale overlap at each end of the travel should be about equal. Transfer signal generator leads to **A** and **E** sockets, or couple the output loosely with the frames via a turn of wire round the case.

MW.—Switch set to MW, and turn **C17** to minimum, keeping the gain control at maximum. Tune to 200 m on scale, feed in a 200 m (1,500 KC/S) signal, and adjust **C24**, then **C19** and **C22** for maximum output. Check calibration at various positions on the scale, and see that the range of **C17** is within the required limits, re-adjusting **C19** if necessary. Adjust the MW pointer to the position which offers the best compromise at all positions of the scale.

LW.—Switch set to LW, tune to 1,000 m on scale, feed in a 1,000 m (300 KC/S) signal, and adjust **C20** for maximum output. Check calibration at various points on the scale, and adjust the LW pointer for the best compromise at all parts of the scale.

Finally, adjust **C19** on a broadcast signal, if necessary.

MARCONI 255MC (Moving Coil Spe

THE principal differences in the MC models, apart from the inclusion of a moving coil speaker, are that all GB potentials are fixed and are not obtained automatically; that gain control is by a screen feed potentiometer; that the intervalve transformer **T1** is paralleled; and that the condenser block contains only four condensers.

Less important differences are in the shape of **T1**, the omission of **C19**, the layout beneath the chassis, an additional battery lead and the omission of the local/distant switch.

Our plan view is used in connection with both types, but a separate circuit diagram and under-chassis view are given for the MC models. The valve base diagrams are the same for both types, and are not repeated.

**CIRCUIT DESCRIPTION
(MC Model)**

Tuned frame aerial input, **L1, L2, C18**, with manual trimmer **C17** for final adjustment, to RF tetrode valve (**V1, Marconi metallised S21**) which operates as signal frequency amplifier with anode circuit tuning by **L3, L4** and **C21**. Provision for connection of external aerial via **C1**, and an earth.

Second valve (**V2, Marconi metallised HL2**) is a triode operating as local oscillator. Anode coils **L7 (MW)** plus **L8 (LW)** are tuned by **C23**. Parallel trimming by **C24 (MW)** and **C4 (LW)**; tracking by specially shaped vanes of **C23**. Reaction coupling from grid circuit by coil **L6**.

The tuned RF output from **V1** anode circuit is conveyed via mixer coil **L5**, which is inductively coupled to the oscillator circuit and thus picks up the oscillator frequency, via isolating condenser **C6** to control grid circuit of a second RF tetrode valve (**V3, Marconi metallised S21**) which operates as mixer.

Fourth valve (**V4, Marconi metallised S21**) is a third RF tetrode, operating this time as intermediate frequency amplifier. Coupling between **V3** and **V4** is via the transformer **L10, C8**, whose primary and secondary circuits are tuned by condensers **C7** and **C8, C25** respectively to the intermediate frequency. **V4** anode circuit is tuned to the same frequency by **L11, C26**.

Intermediate frequency 125 Kc/s.

Gain control is accomplished by varying the HT voltage applied to the screen grids of **V1, V3** and **V4**. These are all connected to a common junction at the slider of the potentiometer **R3**, which, with **R2**, forms a potential divider across the HT circuit.

IF output from **V4** is passed via **C9** to control grid of a second triode valve (**V5, Marconi**

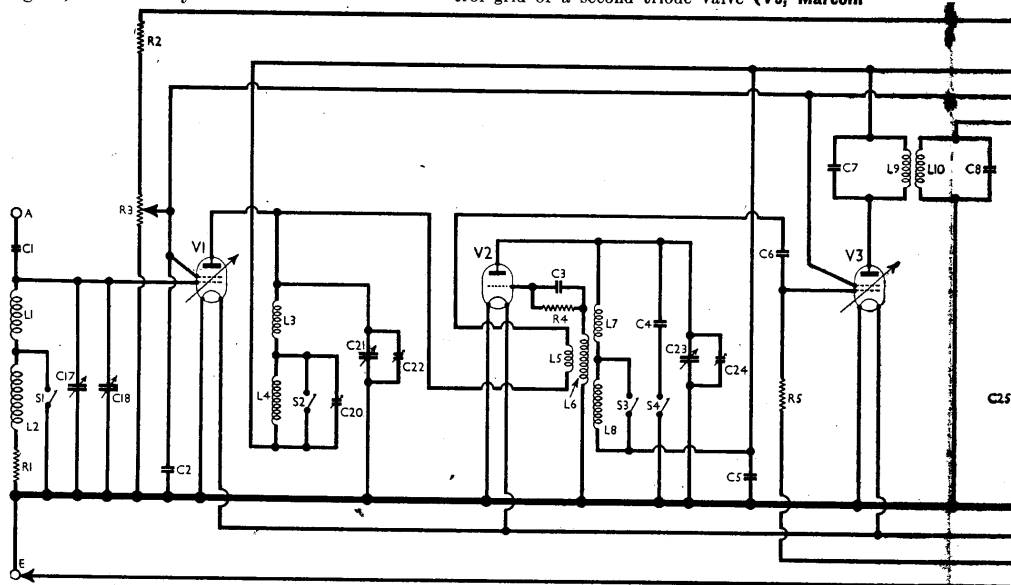

255MC, HMV 459MC Speaker Models)

metallised HL2) which operates as second detector on the grid leak system with C9 and R7. IF filtering by C10 in anode circuit. Provision for connection of gramophone pick-up in control grid circuit.

Parallel-fed transformer coupling by R8, C11 and T1, via grid stopper R9, between V5 and pentode output valve (V6, Marconi PT2). Provision for connection of high impedance external speaker by the terminals to which T1 primary is connected, although a low impedance type could be connected to two of the three terminals of the secondary, according to matching requirements.

VALVE ANALYSIS

(MC Model)

The conditions under which the following table was prepared are similar to those for the cone model, except that the HT positive plug is in the 114 V socket of the battery, and there is no local/distant switch.

Valve	Anode Voltage (V)	Anode Current (mA)	Screen Voltage (V)	Screen Current (mA)
V1 S21	76	1.6	40	1.2
V2 HL2	74	1.5	—	—
V3 S21	76	0.8	40	0.2
V4 S21	76	0.7	40	0.9
V5 HL2	25	1.0	—	—
V6 PT2	110	3.5	80	—

GENERAL NOTES

(MC Model)

Switches.—Except for the omission of S5, the switches for the MC model are the same as for the cone model.

Coils.—All notes on coils from L1 to L11 in the cone model apply equally to the MC model, except that C26 now occupies the position of C10 in the cone model. The fixed condenser is omitted. The only additional coil is L12, the speaker speech coil.

Condenser C17.—See cone model.

Condenser Block.—This occupies the same position on the chassis deck as on the cone model, but it contains only four condensers, which are indicated in the condenser table by asterisks. The colour coding of the leads is: C2, yellow with red tracer; C5, yellow; C12, yellow with black tracer; C13, red. The common lead from the other sides of the condensers is again black.

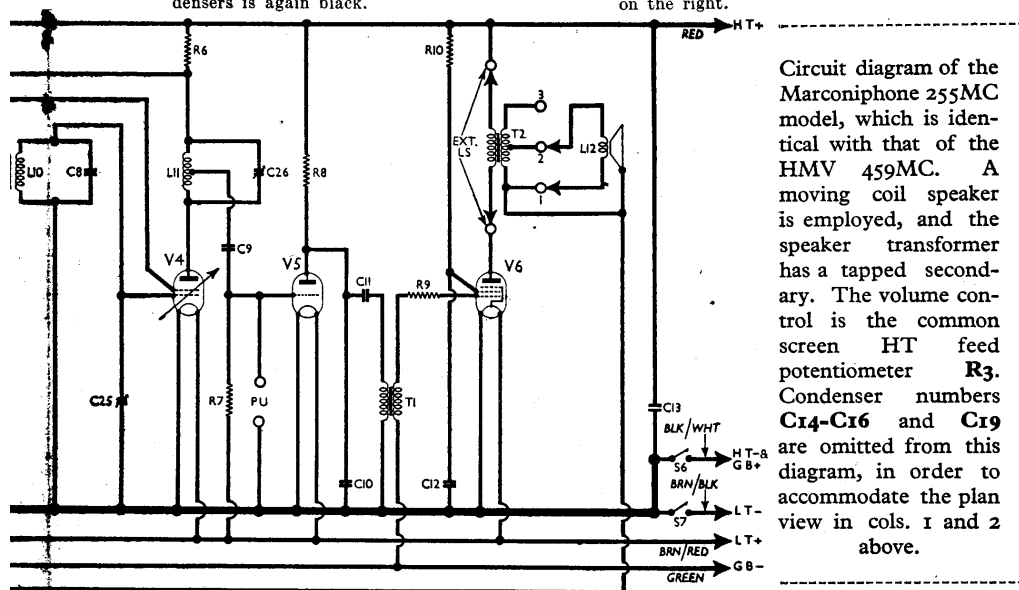

Circuit diagram of the Marconiphone 255MC model, which is identical with that of the HMV 459MC. A moving coil speaker is employed, and the speaker transformer has a tapped secondary. The volume control is the common screen HT feed potentiometer R3. Condenser numbers C14-C16 and C19 are omitted from this diagram, in order to accommodate the plan view in cols. 1 and 2 above.

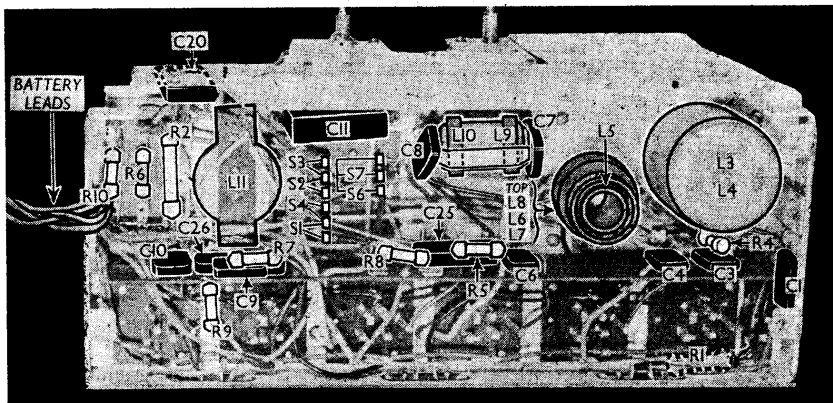

Under-chassis view of the Marconiphone 255MC and HMV 459MC models. The switches are in the same positions as in the cone chassis. R3 is on the chassis deck, where it replaces R10 in the cone model. C2, C5, C12, C13 are in the block on the chassis deck.

Gramophone Pick-up.—See cone model.

External speaker.—Arrangements here are the same as for the cone model, but a low impedance speaker could be connected to two of the three terminals of T2 secondary.

Batteries and Leads.—These are the same as for the cone model, except that the black/white lead goes to the HT-, GB+ tapping on the HT battery, and the green lead to GB-.

Transformer T1.—This is different from T1 of the cone model. It is parallel-fed, and of smaller dimensions, and is enclosed in a square metal container, although it occupies the same position on the chassis deck. Its four connecting leads are colour coded as follows: primary, grey to C11 and white to chassis; secondary, grey to R9 and yellow to GB- lead.

Circuit Alignment.—This is the same as for the cone model, except that there is no C19. This number, together with C14, C15 and C16, have been omitted from the MC circuit diagram.

DISMANTLING THE MC MODEL

Removing Chassis.—Proceed as instructed for cone model, with the addition of removing black speaker earthing lead from the earth terminal, and removing the metal batten (four round-head wood screws) which runs across the case behind the speaker.

Removing Speaker.—Disconnect the three speaker leads and remove the metal batten, as indicated above; free the speaker leads from the cleat on the side of the case; remove from the front of the case the three ornamental headed fixing screws.

When replacing, the transformer should be on the right.

COMPONENTS AND VALUES (MC MODEL)

RESISTANCES		Values (ohms)
R1	Aerial LW damping ...	100
R2	V1, V3, V4 SG's HT feed ...	20,000
R3	Gain control ...	100,000
R4	V2 CG resistance ...	50,000
R5	V3 CG resistance ...	1,000,000
R6	V1-V4 anodes HT feed ...	5,000
R7	V5 CG resistance ...	230,000
R8	V5 anode HT feed ...	50,000
R9	V6 grid stopper ...	500,000
R10	V6 SG HT feed ...	5,000

CONDENSERS		Values (μF)
C1	Aerial series condenser ...	0.00005
C2*	V1, V3, V4 SG's RF by-pass ...	0.5
C3	V2 CG condenser ...	0.0002
C4	Osc. circ. LW trimmer ...	0.0002
C5*	V1-V4 anodes RF by-pass ...	0.5
C6	V3 CG condenser ...	0.0001
C7	IF transformer tuning condensers ...	0.0003
C8	IF transformer tuning condensers ...	0.0001
C9	V4 to V5 IF coupling ...	0.002
C10	IF by-pass ...	0.002
C11	AF coupling to T1 ...	0.1
C12*	V6 SG decoupling ...	0.1
C13*	HT circuit reservoir ...	2.0
C14	—	—
C15	Omitted from MC model ...	—
C16	—	—
C17†	Frame manual trimmer ...	0.0001
C18†	Frame aerial tuning ...	—
C19	Omitted from MC model ...	—
C20†	V1 anode LW trimmer ...	0.0001
C21†	V1 anode circuit tuning ...	—
C22†	V1 anode MW trimmer ...	—
C23†	Oscillator circuit tuning ...	—
C24†	Osc. circuit MW trimmer ...	—
C25†	IF trans. sec. trimmer ...	0.0003
C26†	V4 anode IF tuning ...	0.0003

* In condenser block. † Variable. ‡ Pre-set.

OTHER COMPONENTS		Approx. Values (ohms)
L1-L11	All same as for 255 cone model ...	—
L12	Speaker speech coil ...	4.0
T1	Intervolve { Pri. ...	320.0
	trans. { Sec. ...	2,700.0
T2	Speaker in-put trans. { Pri. ...	950.0
	{ Sec., total ...	3.5*
S1-S4	Waveband switches ...	—
S5	Omitted from MC model ...	—
S6	HT circuit switch ...	—
S7	LT circuit switch ...	—

* Terminals 1 and 2, 1 ohm; terminals 2 and 3, 2.5 ohms.