

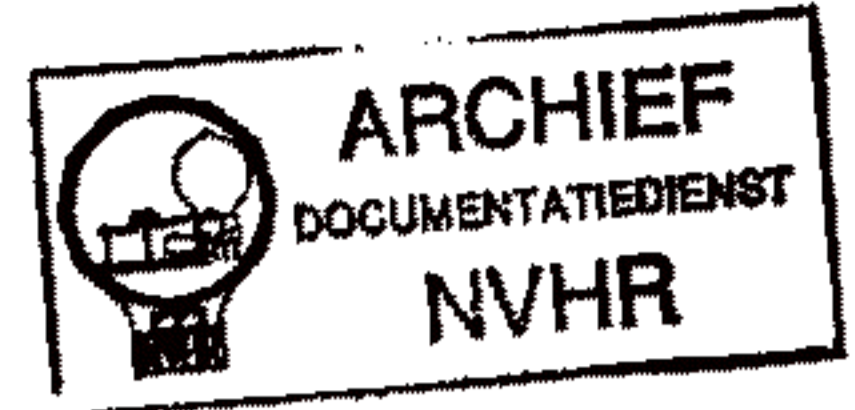

111 Powdermill Road, Maynard, Mass.

Ned. Ver. v. Historie v/d Rad



SERVICE BULLETIN FOR MODEL 340 TUNER - AMPLIFIER

SPECIFICATIONS

(These are minimum-all H. H. Scott Model 340 tuner-amplifiers must meet or exceed these figures.)

TUNER (FM-MPX)

Table with 2 columns: Specification (Usable Sensitivity, Signal to Noise Ratio, etc.) and Value (2.5 microvolts, 60 db, etc.)

PRE-AMPLIFIER

Table with 2 columns: Specification (Output, Input, NAB Tape Equalization) and Value (0.5 V, 100 K, 47 K, etc.)

AMPLIFIER

Table with 2 columns: Specification (Maximum power output, Harmonic distortion, Frequency response, etc.) and Value (30 watts, 0.8%, 20 to 20,000 cycles, etc.)

(These characteristics are measured at a line voltage of 117 volts rms and line frequency of 60 cycles per second. No significant changes of characteristics should be experienced for normal variations of line voltages or a line frequency of 50 cycles per second.)

Table with 2 columns: Specification (Range of line voltage and frequency, Power consumption) and Value (105-125 volts, 240-300 watts)

* All H. H. Scott amplifiers and preamplifiers incorporate a low frequency rolloff which becomes full operative below 20 cycles. This is designed to prevent overload of the output stage and the loudspeaker due to subsonic rumble frequencies and record eccentricity. This means that the full power of the amplifier can be concentrated into the audible range.

GENERAL SERVICE NOTES

Service, other than replacement of either pilot lights or vacuum tubes, is usually not required. If the tuner is not operating properly, all external connections should be checked to make sure that the difficulty is in the tuner. Generally, it is advisable to replace the tuner with a tape recorder or similar device to check out the amplifier performance. If the difficulty appears to be located in the tuner, the level control should be first checked to insure that it is rotated away from its extreme counter-clockwise position. Then, the vacuum tubes should be checked by replacing them with new ones, one by one. The tubes should be tight in their sockets and provided with shields where applicable. Tube defects frequently do not show up in a tube tester. Only operation in the tuner will insure the proper working of a vacuum tube. In replacing tubes, if possible, use exact replacement tubes, available from H. H. Scott or any authorized warranty service station. Other tubes will work, but only exact replacement tubes can give the full performance that the tuner is capable of.

The pilot light may be simply replaced by the following procedure:

1. First, set the tuning dial so that the heavy white lines line up with the pointers on the dial and the logging scale is towards the top of the panel. In this position, the tuning condensers are closed.
2. Unscrew and remove the tuning knob and dial. This will permit access to the pilot light which is a #47 bulb.

After the bulb has been replaced, use the following procedure:

1. Close the condenser plates by rotating the condenser to the extreme counter-clockwise position.
2. Replace the dial, lining up the heavy white lines of the dial with the pointers and keeping the logging scale toward the top of the front panel.
3. Replace the tuning knob.

ALIGNMENT INSTRUCTIONS FOR FM SECTION

Note: No attempt should be made to align the tuner or repair it unless the person so doing has had extensive experience in tuner alignment and repair procedures and has the necessary laboratory equipment. Without proper experience or equipment, the repairman may seriously damage the tuner.

1. Equipment required: VTVM (AC), FM Signal Generator (must be Measurements 210AB or equivalent), Oscilloscope, 400 cps null, and insulated alignment tools.
2. Equipment setup: Connect signal generator directly to the 300 ohm antenna input of the tuner using a matching impedance network if necessary. The left Channel (A) tape recorder output of the 340 then feeds into the 400 cps null and from the null to the oscilloscope and VTVM in parallel. If no null is available (a schematic for making one of these very simple and useful devices is available from the Engineering Department) the tuner can still be serviced. However, it will not be possible to measure the tuner's "Usable Sensitivity" as per IHFM standards or align the detector.
3. Allow tuner and test equipment to warm up fully before beginning alignment. Adjust line voltage for 117 volts. Remove bottom cover of tuner. Always tune primary and secondary of I.F. transformers at the same time, using one alignment tool in each hand. Set 340 Input Selector Switch to FM Mono, AGG switch to Mono.
4. Set generator and tuner for 92 mc. Generator should be modulating a 400 cps signal at 75 kc deviation. Adjust output of generator so that a barely adequate sine wave appears on the scope (on the order of 3 to 6 microvolts input to tuner). The null filter should be switched out of the setup, so the tuner is feeding directly to the VTVM and scope. Peak the I.F.'s for maximum AGC reading on the tuning meter of the 340 (not the VTVM).
5. Increase generator output to 1000 microvolts. Peak the primary of the ratio detector (bottom slug) for maximum audio output (on the VTVM). Switch the 400 cps null into the circuit. Tune ratio detector secondary (top slug) for minimum reading on the VTVM.
6. Return generator output back down to 3 to 6 microvolts. Adjust antenna coil (under chassis) for maximum output. Tune generator and tuner to 106 mc. with same output and deviation, and adjust antenna trimmers (on top - FM ANT.) for maximum output. Repeat this operation until best results are obtained.
7. If calibration is off, repeat "6" except adjust oscillator coils (under chassis) for correct tracking at 92 mc. and oscillator trimmer (FM OSC - on top) for correct tracking at 106 mc.

Note: Replace bottom plate before testing.

1. Test for IHFM Usable Sensitivity measurements: Use 117 volt regulated line, set generator and tuner at 92 mc, with a 5 microvolt input. Take a reference reading on the db. scale and check for 36-38 db, or more reduction in output with 400 cycle null filter switched in to setup. Repeat at 106 mc. If specification is not met, tuner should be realigned and tubes checked. It is very important that the null filter be carefully adjusted so that it is at exactly the same frequency as the 400 cps modulation being fed in. Otherwise, it will be impossible to obtain stated sensitivity figure. Note that a 5 microvolt output of a 9Hc generator is equivalent to 2.5 microvolts at 9Hc tuner input due to drop through the matching impedance network.
2. Audio output: With 1000 microvolt input, 75 kc deviation, maximum output should be 1.5 to 2.5 volts. (From rec. outputs.)
3. Automatic Gain Control: The maximum permissible difference in output between an input of 6 microvolts and 1000 microvolts is 8 db.
4. FM Hum: At 100 mc., 1000 microvolts input, 400 cycle modulation, take a reference reading and remove modulation. A 50 db drop should be noted.
5. Oscillation Check: Check entire FM band for oscillation, with and without antenna, at 105 and 130 volt line.

PRELIMINARY MULTIPLEX TESTS

Use same equipment described above, plus a good Audio Oscillator.

1. Connect the audio oscillator (400 cps) to the test point input on the multiplex section. Adjust the output of the oscillator for 0.25 volts. Set the 340 controls as follows: Input selector to FM mono and AGC to mono.
2. Measure the output of the tuner (from tape rec. output). It should be 0.8 to 1.5 volts with selector switch in either mono or stereo.
3. With the audio oscillator at 400 cps take a reference reading. It should be down maximum of 2 db at 20 cps., 2-4 db at 2 KC, 7-9 db at 5 KC, 12-14 db at 10KC, 15 KC - 15-18 db drop, a minimum of 21 db at 20 KC, and minimum of 44 db at 40 KC.
4. Turn 340 selector switch to FM Stereo. Set oscillator to 67 KC, 0.25 volts output. Adjust L-502 for minimum output from either Channel A or B. The null is quite broad. If necessary increase output of audio oscillator for better null.

STEREO MULTIPLEX SEPARATION TESTS AND ADJUSTMENTS

Equipment needed: In addition to all the equipment mentioned before you will need Hewlett-Packard 200CD Audio Oscillator or equivalent (with balanced output to ground--oscillator with unbalanced outputs cannot be used), and the H. H. Scott Model 830 FM multiplex stereo generator.

Equipment setup: Use the same arrangement described with the tuner alignment procedure, plus: Connect the Audio Oscillator to the 830 (as described in the 830 Instruction Manual) and the 830 to the FM generator. Set the FM generator for External Modulation.

1. Set audio oscillator to 400 cps, and 830 for left channel (Channel A) signal only. IMPORTANT: The 830 MUST be carefully adjusted for input signal and output phase as described in the 830 Instruction Manual. The output phase must be monitored with a scope to check for variances. If the phase is off even slightly, your alignment will cause the tuner to have poor separation when tuned to station.
2. Set all controls on the 340 for full stereo, (input selector switch to FM Stereo, and AGC switch to Mono). Tune the 340 to the point on the dial where you are transmitting your Channel A signal. Make sure you pick a point on the dial that does not coincide with a local FM station.
3. Adjust the tuning dial for maximum reading on the tuner's meter. Take a reference reading on the VTVM, db scale. Remove the output cable from the tuner's Channel A tape rec. output and insert it into the tuner's Channel B output. The difference in output should exceed 30 db. Adjust the top of L-501 with a detector alignment tool for maximum separation. Then turn the pot marked "Sep" for maximum separation.
4. Readjust the 830 so it now provides a right channel signal only (Channel B). Repeat step 4, only the output of Channel A from the tuner should be 30 db down, from Channel B.
5. It is important to realize that maximum meter reading will not exactly coincide with maximum audio output (within 2 db) and maximum separation. However, it comes extremely close to both and does give a good combination of separation, output, and low distortion.

EMERGENCY MULTIPLEX SEPARATION ADJUSTMENTS WITHOUT SPECIAL TEST EQUIPMENT

The following adjustments should only be attempted if it is impossible to get the proper multiplex test equipment and it is obvious that stereo separation is not satisfactory. The only way to be sure the tuner is at fault is to substitute another tuner, known to be working properly. (Very often a tuner will not appear to have good separation when actually the station or the program material is at fault.)

The primary requirement is to have a local FM station broadcasting multiplex stereo with spoken announcements on one channel only. Most multiplex stations do provide this service at certain times of the day. Call the station and check. If they are among the few that are not broadcasting speech on one channel only, you might point out how valuable it would be to service people in their area if they did.

1. Assume the FM multiplex station is transmitting commercials on the right channel only (reverse everything if it is left only.)
2. Connect an audio cable from Amplifier's Channel A output to a speaker.
3. Tune in the station carefully using the tuning meter. Set input selector to FM Stereo, sub-channel filter to out, scratch filter to out, ACG to Mono, volume to quite loud.
4. When the announcer begins to talk, he should be barely audible in Channel A or the left channel signal. Carefully retune till you find the point where the sound is faintest (you should be quite close to the maximum meter reading position.)
5. Carefully rotate the "Sep" pot on the multiplex adaptor until the voice is at its faintest. Keep the volume up on the amplifier.
6. If this does not provide sufficient improvement, take the detector alignment tool and insert it into the top of L-501. Rotate slowly for the best separation point. Then readjust the "Sep" pot.
7. If this does not help, the difficulty may be with the station or with some other part of the system.

AMPLIFIER SECTION

GENERAL SERVICE NOTES

1. Check the tubes, particularly those in the power output stage and the rectifier every year. If the tubes are outside the manufacturer's ratings or show gas, they should be replaced. Gassy tubes may damage other components of the circuit.
2. When the 340 is being checked yearly, clean the tubes of dust so that they may radiate their heat more effectively.
3. If at any time the hum or noise increased noticeably, check the power tubes, for this symptom is often an indication of gassy tubes.
4. If the 340 blows fuses frequently, check the line voltage. If it rises above 125 volts, drop the line voltage by means of an auto-transformer or place a voltage regulator transformer between the amplifier and the line. If the line voltage is correct, check the amplifier itself. Do not use fuse sizes other than the fuse size specified.
5. D.C. Balance Adjustment:
Equipment needed - Oscilloscope and/or AC VTVM, 16 ohm resistive load of adequate wattage (some wirewound resistors have considerable residual inductance and these should be avoided.)
The balance pot for each output stage is located between the output tubes for that stage. These controls should be adjusted when the output tubes age appreciably or are replaced. To set these controls use the following procedure:
 - (a) Connect the 16-ohm resistor across the output terminal of the channel under test.
 - (b) Connect the oscilloscope and/or VTVM across the resistor, and turn the horizontal selector of the scope to "LINE".
 - (c) Remove the phase inverter tube 6U8/6GH8 of the output stage under test.
 - (d) Adjust the proper D.C. Balance Control for a minimum 120 cycle response on the scope or minimum reading on the AC VTVM.
 - (e) Repeat the entire procedure for the other amplifier output stage.
6. Tests can be performed to insure that the unit meets or exceeds the specifications outlined previously. Only use parts and tubes specified by H. H. Scott, Inc. The use of non-standard parts or tubes will preclude obtaining the performance stated in the specifications.

If you have any further questions, write to:



Technical Services Department
H. H. SCOTT, INCORPORATED
111 Powder Mill Road
Maynard, Massachusetts

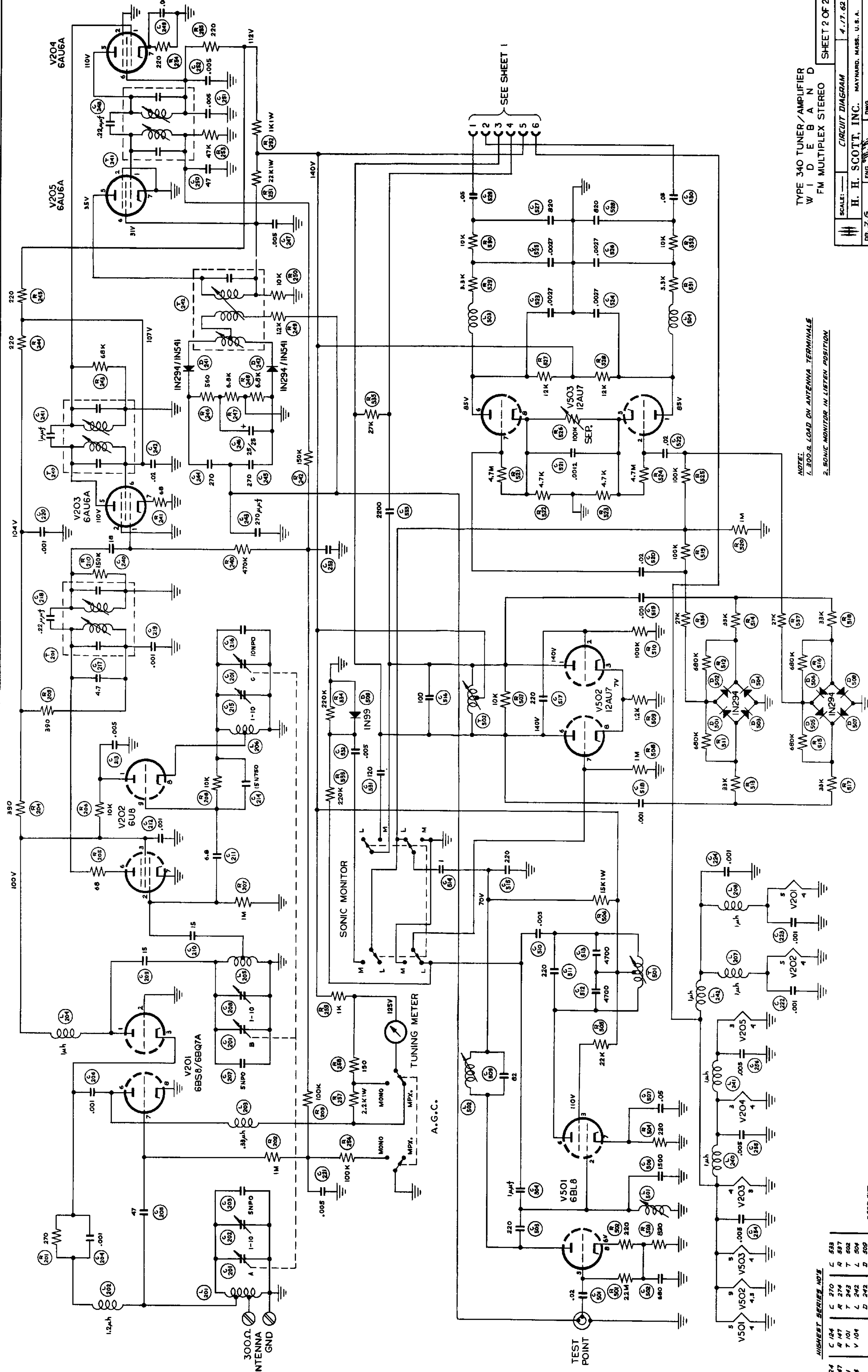

NOTE:
 1. 300Ω LOAD ON ANTENNA TERMINALS
 2. SONIC MONITOR IN LISTEN POSITION

TYPE 340 TUNER/AMPLIFIER
 W I D E B A N D
 FM MULTIPLEX STEREO

CIRCUIT DIAGRAM
 H. H. SCOTT, INC. MAYNARD, MASS., U.S.A.
 DR. J. G. ENG. PROD. NO. D-340-C1 SUB. 1

HIGHEST SERIES NOS

C 124	C 270	C 533
R 47	R 274	R 537
T 1	T 243	T 502
V 4	V 104	V 504
	V 202	V 505
	V 207	V 508

C 508 OUT