

of V1, 2 and 3. Negative feed-back from V4 anode is applied to V4 grid via the network C43.R20.C44.R13.

**CHASSIS REMOVAL** : Remove the screws holding the back cover and move the latter sufficiently to enable the removal of the three knobs and the four screws holding the chassis to the cabinet. Lift out the chassis and back cover complete.

**I.F. ALIGNMENT** : Remove chassis from cabinet. Switch to M.W., set V/C to maximum, fully mesh the gang, connect output meter to loud-speaker tags.

Inject a 460 Kc/s (or 455 Kc/s) signal via a 0.1 mfd. condenser to the control grid of V1.

Adjust the upper and lower cores of I.F.T.2 then I.F.T.1 in that order for maximum output.

**CURSOR SETTING** : With the gang fully meshed, slide the chassis into the cabinet and check the cursor setting. This should coincide with the lines terminating the L.F. end of the scale. Adjust as necessary by sliding cursor along the cord.

**CALIBRATION** : The two cores of the oscillator coils are adjusted at the works and sealed in position, making further adjustment unnecessary. The remaining adjustments are best carried out, with the chassis and back cover replaced in the cabinet, through the holes in the cabinet base.

Inject the signal to aerial socket via a 100 pf condenser.

Set V/C to maximum.

Switch to S.W.

Tune to and inject 15 Mc/s (20 metres) and adjust C18 and C8 for calibration and maximum signal.

Switch to M.W.

Tune to and inject 1200 Kc/s (250 metres) and adjust C20 and C7.

Switch to L.W.

Tune to and inject 300 Kc/s (1000 metres) and adjust C24 and C6.

In the event of the two oscillator cores being tampered with, they should be readjusted at 550 metres and 2000 metres respectively.

**I.F. TRANSFORMERS** : In very early receivers, a few cases of intermittent results have been noticed and the trouble traced to either of these transformers. The eyelet connections at the base had poor contact to one or both of the shunt capacitors. To remedy, scrape clean of wax, etc., and re-solder both sides of the eyelet to ensure a lasting contact.

**WARNING** : As the chassis is "alive", great care must be taken in handling when the back cover is removed, or when the chassis is removed from the cabinet for test purposes. This particularly applies to sets working on A.C. mains, or in the case of D.C. mains, where the positive main is earthed.

When working on A.C., it is necessary as an extra precaution, to insert the plug in the mains socket so that the chassis is connected to the earthed side of the mains supply. Test by connecting a capacitor of about 0.1 mfd. (250 volts A.C. working) in series with the earth lead and touching the chassis with the free end of the capacitor.

If sparks occur, reverse the mains plug.

**IMPORTANT** : This test must NOT be carried out unless the capacitor is fitted as above, otherwise, should polarity of the mains be such that the chassis is alive, the indicator lamp will be burned out on touching the chassis with the earth wire.

Do not forget to replace the back cover.

**CIRCUIT DETAILS** : Signal input circuit for S.W. consists of a tuned frame aerial to which an external aerial may be capacitively coupled.

On M.W., a second tuned frame aerial is used in series with the S.W. frame. An external aerial, if used, would be series choke coupled via the frame tapping.

For L.W., a loading coil is connected in series with S. and M.W. frames to form the secondary circuit, provision being made for coupling an external aerial via the high impedance primary coil.

On S.W. and M.W. the unused secondary coils are short-circuited to chassis.

The oscillator circuits, tuned anode, are quite conventional.

Transformer coupling is used on S.W. and M.W., while on L.W. the osc. circuit is of the colpitts type.

From the anode of the mixer V1, the I.F. signal is transformer coupled to V2, amplified and again transformer coupled to the demodulator diode of V3.

The A.F. component is filtered by C30.R10, C31 and coupled via the volume control R11 and C32 to V3, amplified and then R.C. coupled to V4 for final amplification. V4 output is transformer coupled to the permanent magnet loud-speaker.

Valves 1 to 4 are individually cathode biased. In the case of V3, the valve current is very low and to assist in developing the required voltage across R18, the bottom of the potential divider R3.R4 is connected to V3 cathode.

AVC is obtained by rectifying a small part of the signal from V2 anode by V2 diode, the output being filtered and applied to the grid

**THE 'CONSORT' MODEL, U76**, is a five valve, including rectifier, transportable superheterodyne receiver covering SW, MW and LW bands and designed to operate from A.C. or D.C. mains.

It is housed in a two-colour plastics cabinet and its three controls are fitted to the sides, blending into the contour of the cabinet. On the left side is the Volume On-off, and on the right, Tuning and the Wave-change switch. Built-in frame aerials are provided for S.W. and M.W. which in conjunction with a loading coil are effective on L.W. An external aerial is only required for extended range or in areas of low field strength.

**MAINS SUPPLY** : A.C. 200-250 volts. 40-100 c.p.s.

D.C. 200-250 volts.

Provision is made for the receiver to operate from 110-130 mains, the output level being correspondingly reduced.

For operation at full output on 110-130 volts (A.C. only), a booster transformer for the H.T. section is available together with full instructions for its installation.

**CONSUMPTION** : 185 m.a. with 230 volts A.C. input.

178 m.a. with 230 volts D.C. input.

**VALVES** : V1—UCH42, Frequency changer.

V2—UAF42, I.F. amplifier and A.V.C. diode.

V3—UAF42, Demodulator diode and A.F. amplifier.

V4—UL41, A.F. amplifier.

V5—UY41, Half wave rectifier.

All valves are Mullard and use the B8A socket, the electrode connections of which are given in the diagrams.

For V2 and V3, the sockets are wired to take either the UAF41 or UAF42 as direct replacements without further modification.

**INDICATOR LAMP** : 6.2 volts, 300 m.a. MES type.

**WAVERANGES** : Short-wave. 16—49 metres.

Medium-wave. 200—550 metres.

Long-wave. 1000—2000 metres.

**INTERMEDIATE FREQUENCY** : N—460 Kc/s. S—455 Kc/s. A letter N or S is printed near the centre of the back cover and the I.F. is stamped above the serial number at the rear of the chassis.

**LOUD-SPEAKER IMPEDANCE** : 3 ohms at 400 c.p.s. No provision is made for an extension speaker.

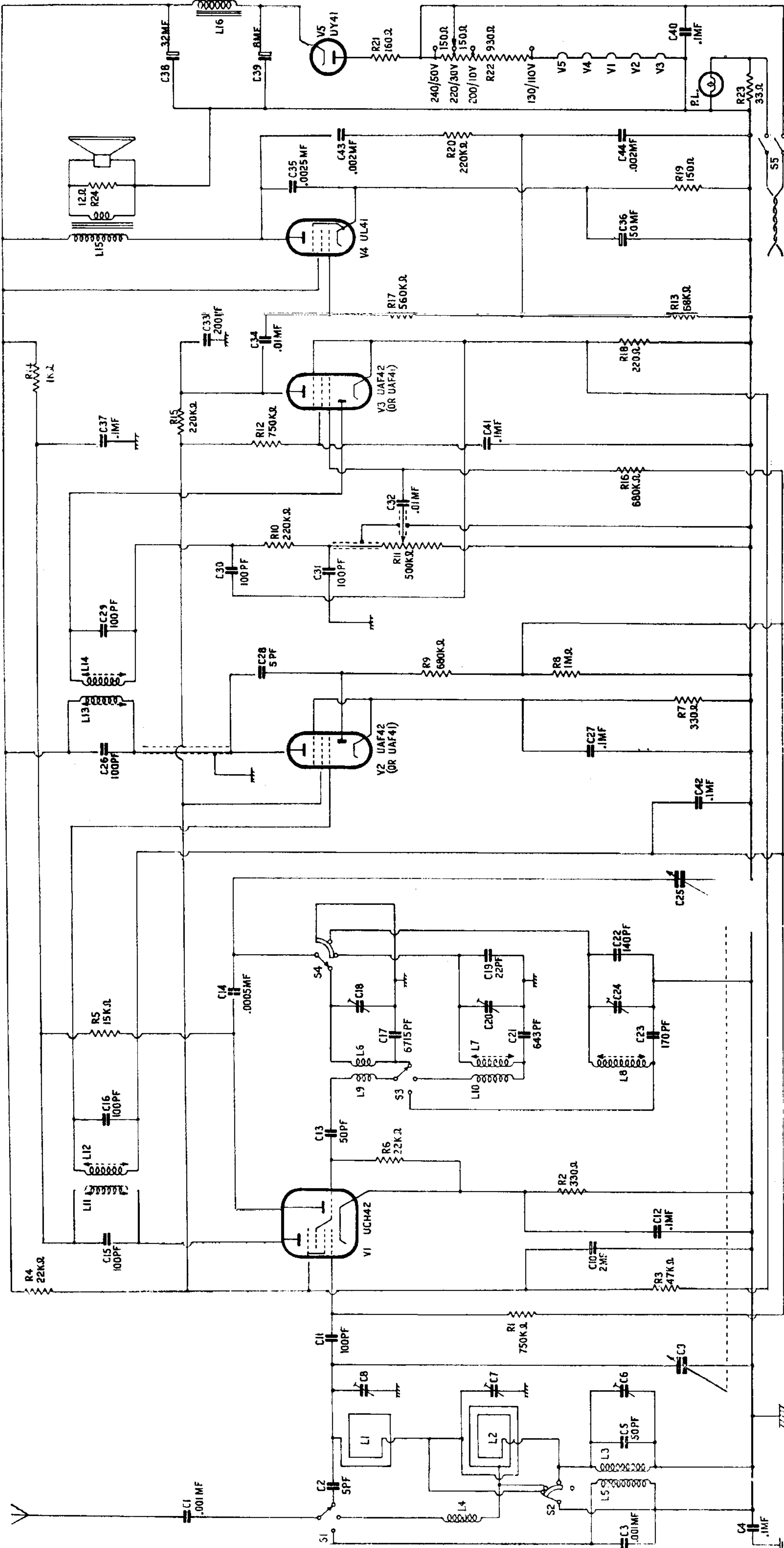

CIRCUIT DIAGRAM

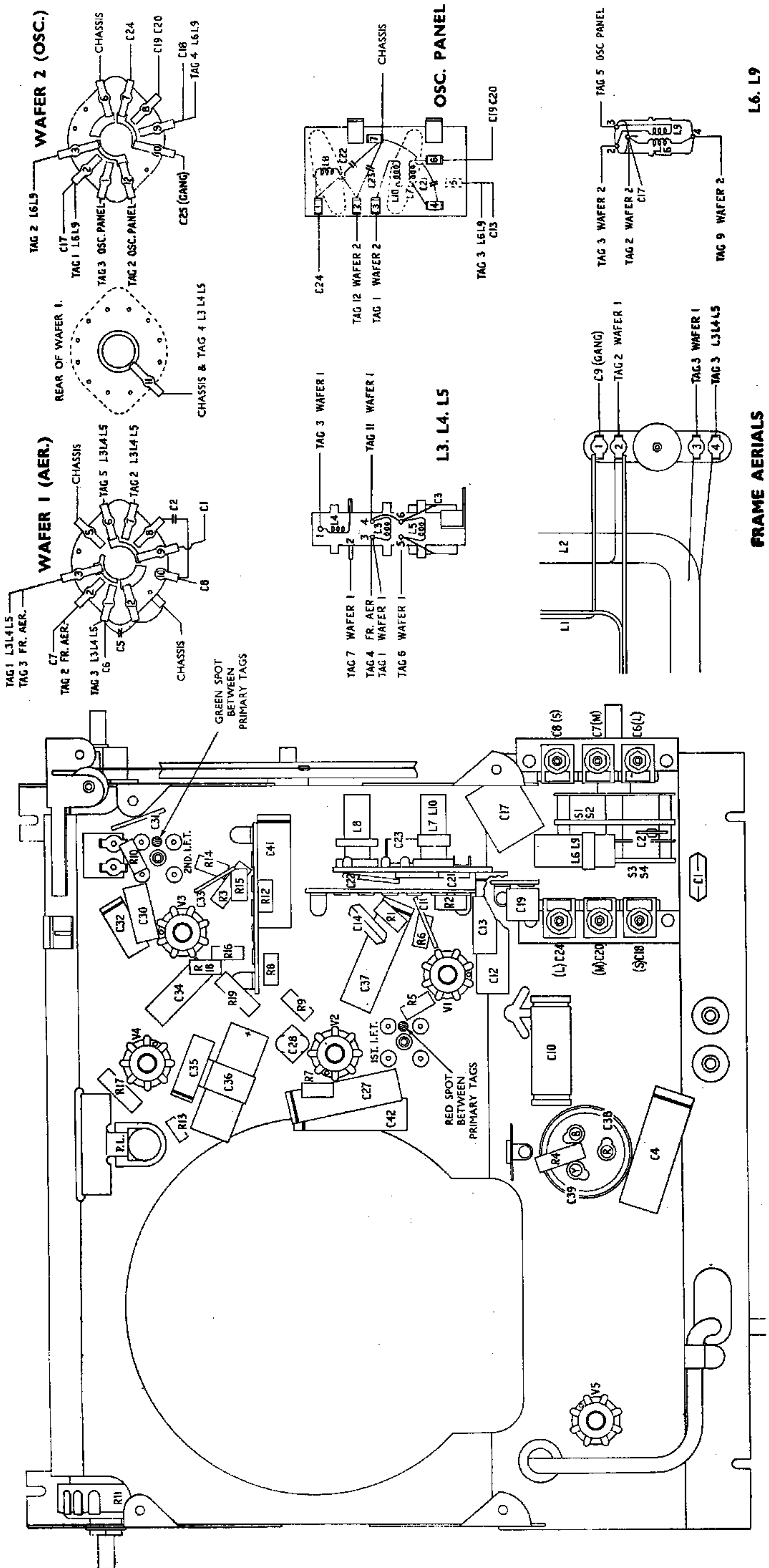

**FRONT OF CHASSIS AND COMPONENT DETAILS**

L6, L9

**DRIVE CORD DETAILS**

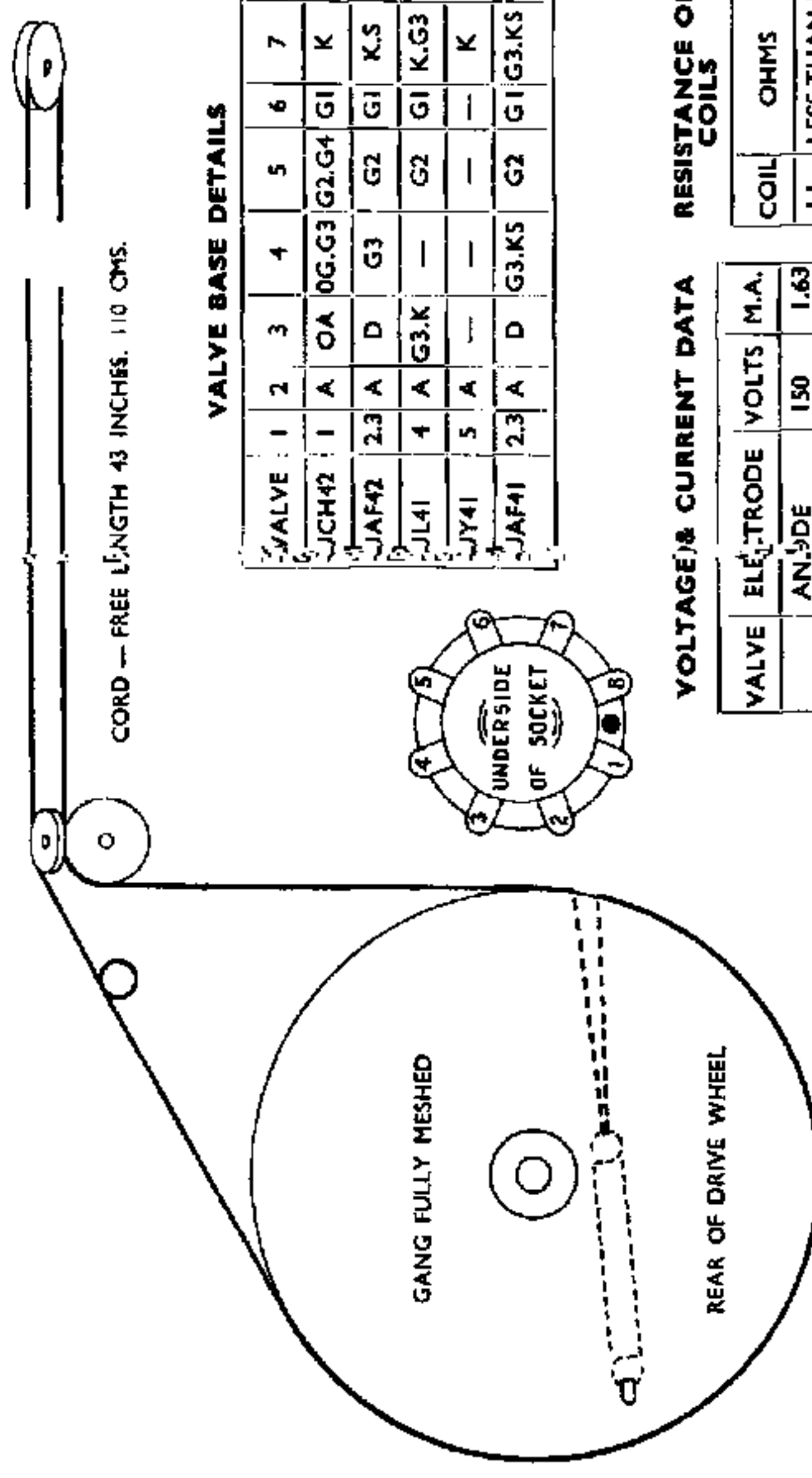

**VALVE BASE DETAILS**

VALVE	1	2	3	4	5	6	7	8
JCH42	1	A	OA	OG.G3	G2.G4	GI	K	H
JAF42	2.3	A	D	G3	G2	GI	K.S	H
JL41	4	A	G3.K	—	G2	GI	K.G3	H
JY41	5	A	—	—	—	—	K	H
JAF41	2.3	A	D	G3.KS	G2	GI	G3.KS	H

**VOLTAGE & CURRENT DATA**

VALVE	ELE. TRODE	VOLTS	M.A.
1	AN. DE	150	1.63
	OSC. ANODE	90	4.52
	SCR. GRID	82	2.62
2	CATHODE	2.9	8.77
	AN. DE	152	3.4
	SCR. GRID	82	1.2
3	CATHODE	1.6	4.6
	AN. DE	—	0.32
	SCR. GRID	—	0.08
4	CATHODE	0.6	2.6
	ANODE	135	41.5
	SCR. GRID	145	7.9
5	CATHODE	7.2	49.4
	ANODE	217	—
	CATHODE	175	66

**RESISTANCE OF COILS**

COIL	OHMS
L1	LESS THAN 1
L2	LESS THAN 1
L3	25
L4	16
L5	25
L6	LESS THAN 1
L9	LESS THAN 1
L7	2
L10	LESS THAN 1
L8	6
L11	16
L12	16
L13	16
L14	16
L15P	460
L15S	LESS THAN 1
L16	375 ± 10 %

SET AT 550 METRES. NO SIGNAL.  
230 VOLTS A.C. INPUT.  
20,000 OHMS/VOLT METER.

**OUTPUT TRANSFR. L15**

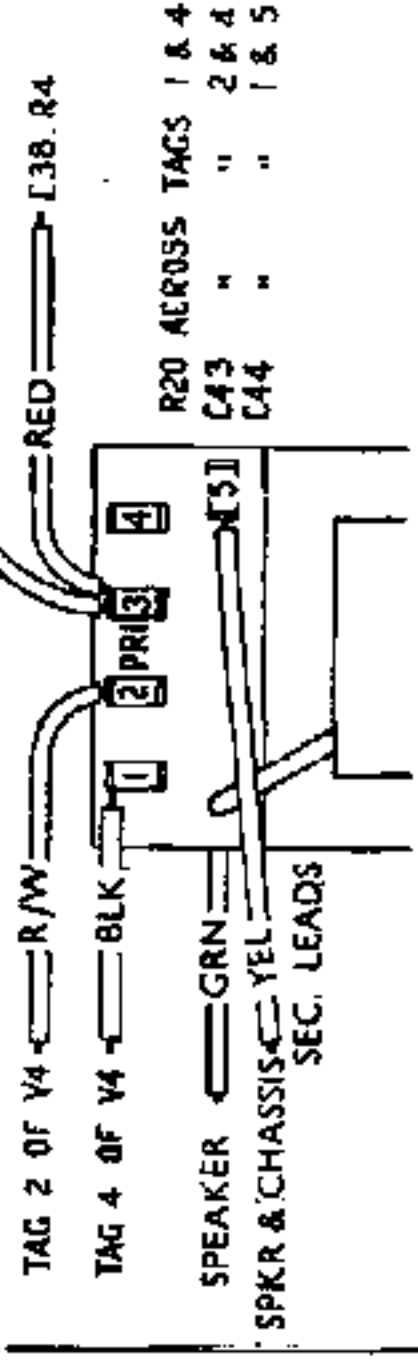

**VOLUME CONTROL**

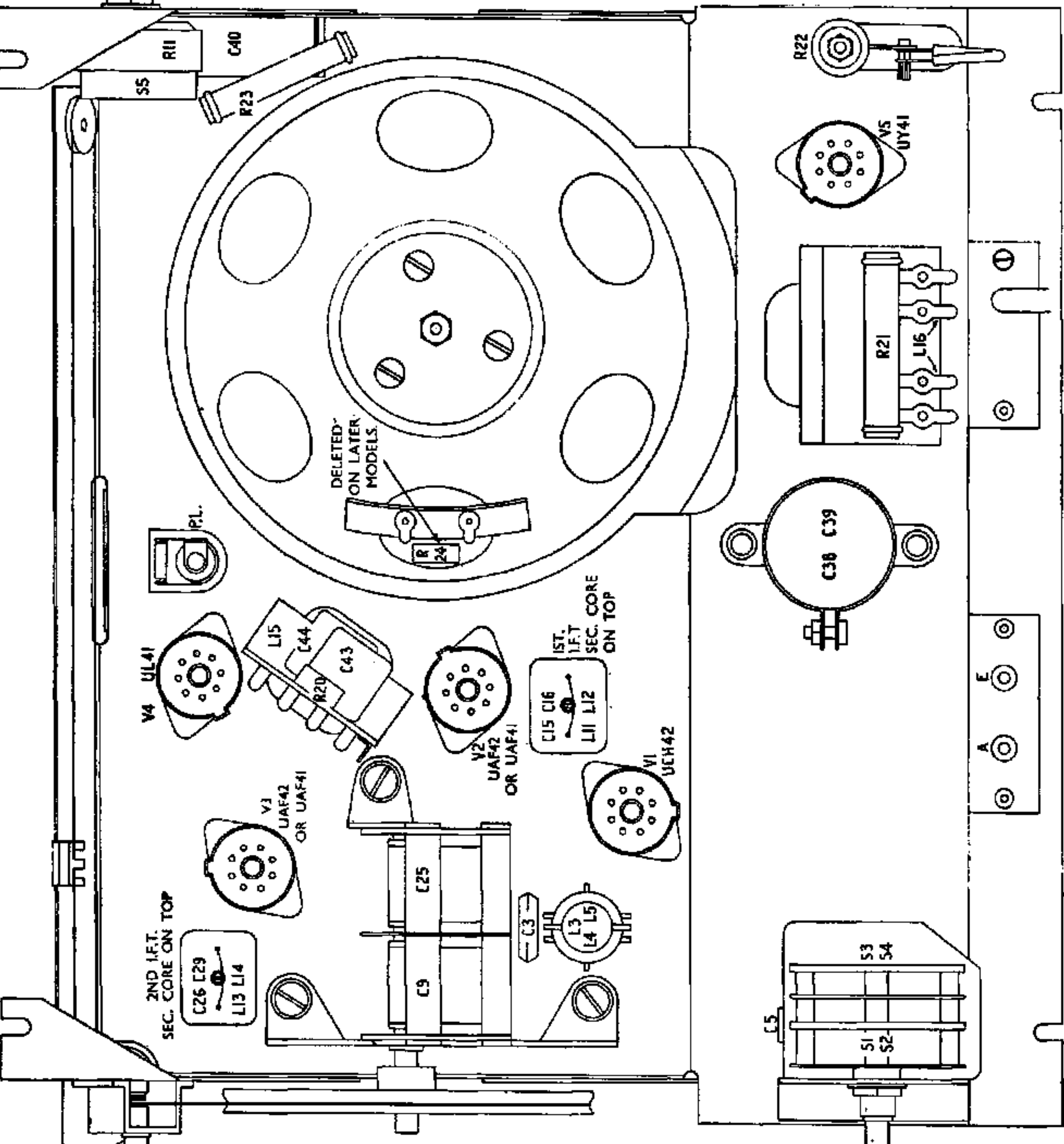
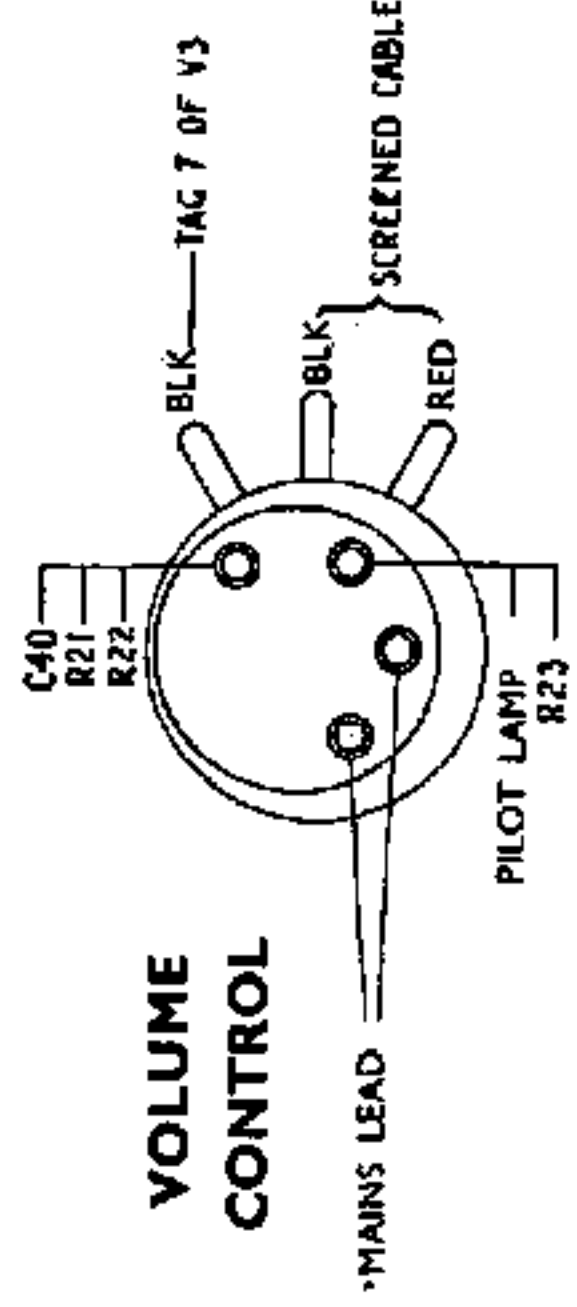

**SCOTTISH SERVICE DEPOT:**  
Duchess Road,  
Rutherglen, Lanarkshire  
Phone: Rutherglen 2240/3

**NORTHERN SERVICE DEPOT:**  
55, Whitworth Street,  
Manchester  
Phone: Central 6711/2

**WESTERN SERVICE DEPOT:**  
4, Redcross Street,  
Bristol  
Phone: Bristol 26311

**SERVICE DEPT., E. K. COLE Ltd.,**  
Somerton Works, Arterial Road,  
Southend-on-Sea  
Phone: Southend 2296  
Head Office: Ekco Works, Southend-on-Sea



# EKCO ADVANCE SERVICE INFORMATION

MODEL U76

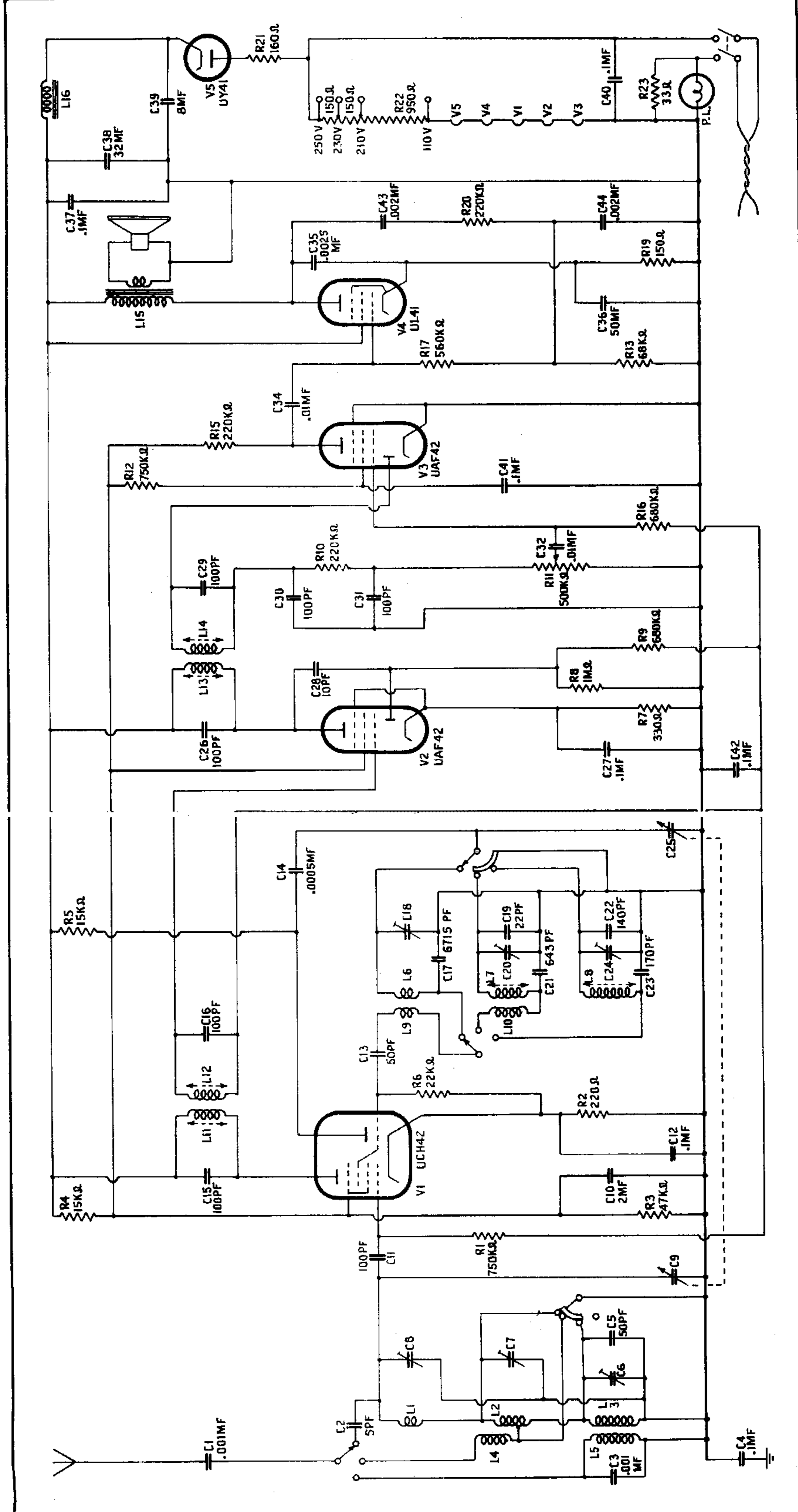

# EKCO ADVANCE SERVICE INFORMATION

MODEL U76

## DRIVE CORD FITTING

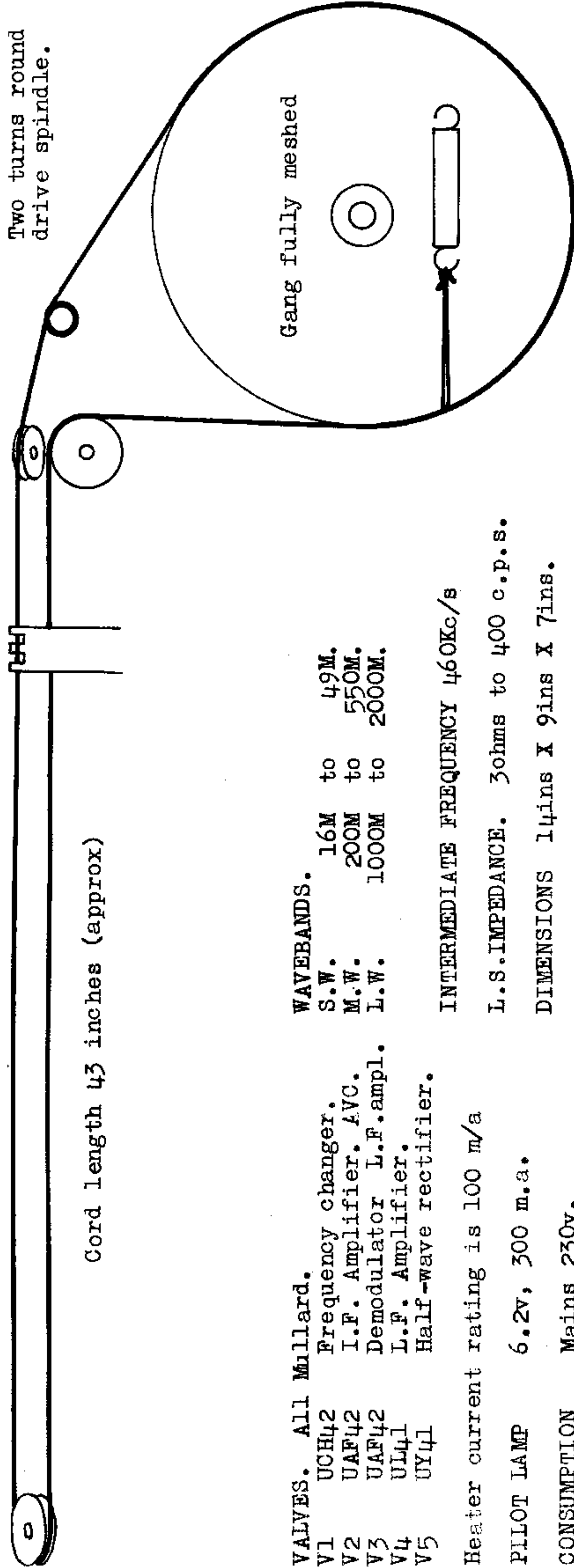

Cord length 43 inches (approx)

VALVES. All Mullard.  
 V1 UCH42 Frequency changer.  
 V2 UAF42 I.F. Amplifier. AVC.  
 V3 UAF42 Demodulator L.F. ampl.  
 V4 UL41 L.F. Amplifier.  
 V5 UY41 Half-wave rectifier.

Heater current rating is 100 m/a

PILOT LAMP 6.2v, 300 m.a.

CONSUMPTION Mains 230v.

A.C. 185 m.a. D.C. 178 m.a.

### WAVEBANDS.

S.W. 16M to 49M.  
 M.W. 200M to 550M.  
 L.W. 1000M to 2000M.

INTERMEDIATE FREQUENCY 460Kc/s

L.S. IMPEDANCE. 3ohms to 400 c.p.s.

DIMENSIONS 14ins X 9ins X 7ins.

WEIGHT (Chassis only) approx 8 lbs.

In certain districts, models will have an Intermediate Frequency of 455 KC/s.