

# Eddystone

## SOLID-STATE BROADCAST RECEIVER

### MODEL EB37

#### INSTRUCTION MANUAL

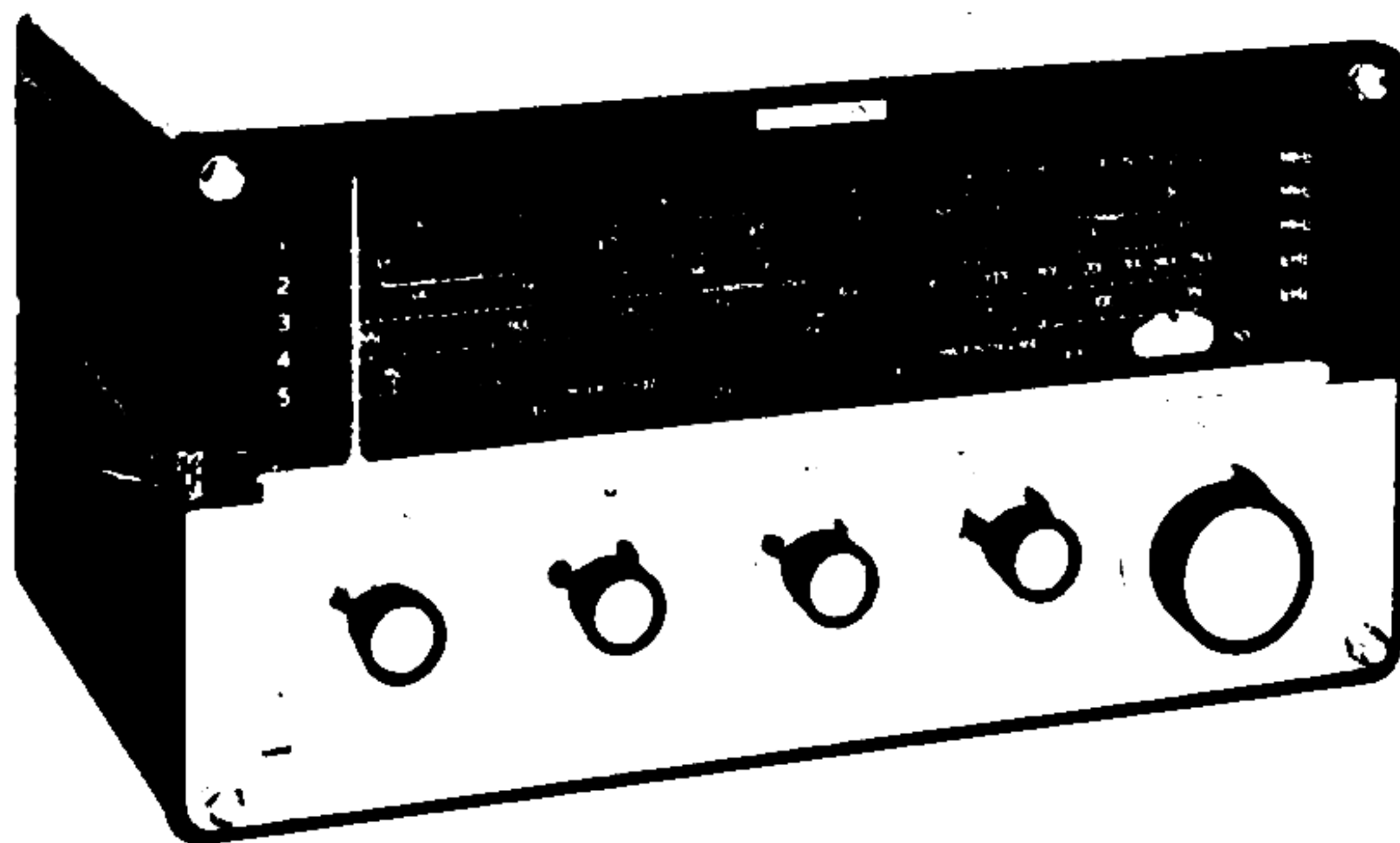

The EDDYSTONE Model EB37 is a fully transistorised receiver designed and produced primarily for the enthusiastic broadcast listener whose requirements are not entirely fulfilled by the average domestic "wireless set". Normal long and medium wave reception is provided together with continuous short-wave coverage down to the popular 16-metre band. The receiver is normally powered from a self-contained battery pack but provision is made for mains operation using a special power unit which fits into the battery compartment.

Ten transistors and five diodes are employed in the high-performance circuit which is based on the well-proven "EC10" communication receiver in use by professional and amateur operators throughout the world. The design makes use of a fully-tuned r.f. amplifier stage which ensures excellent reception even when using a short inefficient aerial. An overload protection circuit is incorporated to prevent damage to the receiver when used in close proximity to a high-powered transmitter.

Facilities are available for using the receiver as a high-quality "tuner" to feed a tape recorder or "hi-fi" outfit. In this role, the external unit can remain perm-

anently connected ready for immediate use without affecting the normal functions of the receiver in any way. The internal loudspeaker can be employed for monitoring purposes or telephones can be used where this is more convenient.

Versatility is further enhanced by making provision for using the audio stages of the receiver in conjunction with an external pick-up, tape-deck or microphone. Many varied applications will be found for the receiver when used in this manner.

Construction follows much the same pattern as that found on the professional receivers in the Eddystone range. Styling is in keeping with modern trends and the receiver will fit nicely into any domestic decor. Finish is to the highest standard with attractive metal cabinet.

The complete frequency coverage is divided into five ranges as follows:—

Range 1	.. ..	8.5 — 22.0 MHz. (SW1).
Range 2	.. ..	3.5 — 8.5 MHz. (SW2).
Range 3	.. ..	1.5 — 3.5 MHz. (SW3).
Range 4	.. ..	550 — 1500 kHz. (MW).
Range 5	.. ..	150 — 350 kHz. (LW).

# INSTALLATION

## Batteries

Six standard 1.5 volt dry cells need to be fitted in the internal battery box before the receiver can be put into use. Any of the following batteries may be used, leak-proof types being preferred where available.

EVER READY	U2	OLDHAM	K532
VIDOR	V0002	SIEMENS	T1
DRYDEX	T20/T21	RAYOVAC	3LP

To fit the batteries, first unscrew the two knurled screws which retain the battery box at the rear of the receiver. Carefully remove the box and free it from the receiver proper by disengaging the battery connector. Lay the box on a flat surface and take off the inner cover. Arrange the batteries in two groups of three and then slide them into the battery troughs.

Use the diagram printed on the container as a guide when fitting the batteries and make certain that they are in the correct positions before replacing the box. Switching on with the batteries connected the wrong way round could damage the transistors. Replace the inner cover, re-connect the battery plug (yellow dots adjacent to each other) and then re-fit the box at the rear of the set.

## Mains Operation

The receiver can be operated directly from all standard AC mains supplies by fitting a Power Unit Type 924 in place of the battery container. The P.U. gives an output of 9V and has the same physical size and fixing arrangements as the normal battery box. An instruction sheet is supplied with the power unit which can be ordered through your local stockist. Voltage Converter Type 945 is also available to permit operation from 12 or 24V DC supplies.

## Aerials and Aerial Connections

The type of aerial used with the EB37 receiver will depend to a large extent on the permanency of the installation. Reasonable results may be obtained in a temporary installation with a relatively short length of wire located indoors. Some 15-20 feet of insulated wire run round the picture rail will provide reception from all long and medium stations serving the area; many of the high-powered short-wave stations should also be audible at good strength. Such an aerial is of course relatively inefficient and it should be realised that signals are received only because of the high receiver sensitivity.

An outside aerial is strongly recommended for a permanent installation, permitting reception from a greater number of stations with a lower level of background noise. A suitable aerial could take the form of some 30-60 feet of insulated wire strung between two insulators and located as high as conveniently possible. It should be kept well away from local obstructions (especially those of metallic construction). The down-lead can be taken from either end or from any point along the horizontal top and should be run well clear of house guttering etc. to avoid any loss in the available signal voltage. Soldered joints should be used where connections are necessary.

Aerials of the types so far described are known broadly as "single-wire" or unbalanced aerials and are connected to socket "A1". The socket marked "AE" should be linked to the "EARTH" terminal using the special shorting plug supplied.

Improved results may be obtained when the wire length is less than 15 feet if the "A2" socket is used for the aerial connection. "A2" should also be used for connecting short rod aerials when a longer aerial is not available as for example when using the receiver in a vehicle. Cat. No. 991 Telescopic Aerial is available as an accessory for this receiver.

For serious short-wave reception a further improvement can be obtained if a "balanced" aerial system is employed. One type which falls in this category and involves no difficult constructional problems is the dipole aerial. This takes the form of a letter "T" in appearance, the horizontal portion being the aerial proper and the

vertical section the down-lead or feeder. Any wire of adequate strength (either insulated or bare) can be used for the top while the feeder can be any good quality twisted flex suitable for outside use (e.g. plastic covered). Special feeder cables are manufactured for this specific application but these are more expensive and offer little in the way of advantage for a normal domestic installation. They can of course be employed if the user so wishes.

For general short-wave reception the overall length of the horizontal portion should be of the order 50-60 feet, the wire being broken at the centre with each lead connected separately to the feeder cable. An insulator is used at this point to facilitate connection and provide mechanical support for the feeder. The length of the feeder is of minor importance and little attention need be paid to its actual positioning. The aerial proper should be erected as high as conveniently possible using insulators for supporting the two ends of the wire.

If attention is centred in one specific short-wave broadcast band, performance can be optimised at this frequency by cutting the aerial to a predetermined length. Overall lengths for the main broadcast bands are as follows—49m : 76ft, 31m : 48ft, 25m : 39ft, 19m : 30ft, 16m : 26ft. Overall lengths (in feet) for other bands can be calculated by dividing 468 by the frequency in Megahertz. (If wavelength only is known, refer to the following section for instructions on converting to frequency).

When using a twisted flex feeder of the type described above, one feeder wire is connected to the "A1" socket and the other to the "AE" socket. The special shorting plug is removed and can be stored in the "A2" socket to avoid loss. The same connections are employed when using a standard flat twin transmission line. Coaxial feeders are unbalanced and are connected as follows; braid to "EARTH" terminal, inner wire to "A1", shorting plug in position between "AE" and "EARTH" terminal. On the lower frequencies the dipole can be operated as a single-wire aerial by strapping both the feeder wires together and connecting to the "A1" socket. This will give greater signal pick-up and increase the versatility of the aerial.

A dipole aerial suitable for use with the "EB37" is manufactured by Eddystone Radio Ltd. Full details are available on request.

## Earthing.

In some cases it will be found that reception can be improved if an earth connection is made to the "EARTH" terminal. One benefit is a reduction of locally generated electrical interference, especially when listening on the lower frequencies in the tuning range. The earth lead should be as short and direct as possible connected to a water pipe or an external earth rod.

## Connecting telephones or an external loudspeaker.

The "PHONES" socket at the rear of the receiver can be used either for connection of telephones for personal listening or an external loudspeaker which can if required be located some distance from the receiver.

Telephones should preferably be of low impedance and the "high-quality" type are recommended. The external loudspeaker should have an impedance in the range 8-15 ohms and can be any size or type. An external transformer is not required. Twisted flex can be used for connection, using a standard jack plug to mate with the telephone socket. Bulgin Type P38 plug will be found suitable. Inserting the plug into the socket automatically switches off the internal loudspeaker.

## Connecting to a tape recorder or hi-fi amplifier

The socket labelled "TAPE" at the rear of the set can be used to extract a low-level signal for connection to a tape recorder or hi-fi system. A suitable plug is supplied with the receiver and this should be used to terminate a screened cable to feed the external unit. The braid of the cable should be soldered to the neck of the plug shell and the inner wire to the pin.

When using the receiver in this way, it will be found that the normal volume control has no effect on the output level at the "TAPE" socket. The volume control on the tape recorder should therefore be used to control the recording level in the usual manner. The receiver speaker (and telephone output) function normally and either can be used for monitoring when a recording is being made.

Volume must be controlled externally when using the receiver as a "tuner" feeding into a hi-fi system and in this case it is best to set the receiver volume control at minimum.

#### Using the receiver as an audio amplifier.

A second plug is supplied for use when employing the audio stages of the receiver as an amplifier in conjunction with a microphone, gramophone pick-up or tape-replay-head. The socket for this facility is marked "AF INPUT" and is arranged to cut out normal signals when the plug is inserted.

The input has a low impedance and it will be necessary to obtain a suitable matching transformer from your local dealer if a crystal microphone or other high impedance device is to be used.

## OPERATION

The EB37 will be found easy to operate. Controls have been kept to a minimum in the interest of simplicity and the user will quickly become familiar with their functions.

Assuming that a suitable aerial has been connected and that either the battery pack or the mains power unit are in situ, the receiver can be brought into use by moving the SUPPLY SWITCH at the left-hand end of the panel to the "ON" position. The VOLUME and TONE controls should be set initially to their midway positions and can be re-adjusted to suit reception conditions once the desired signal has been selected.

To tune to a specific frequency, first determine the appropriate range by reference to the figures printed at the left-hand end of the calibrated scales. Set the WAVECHANGE SWITCH to the range indicated and then move the tuning pointer to the correct setting by means of the TUNING CONTROL. This has a larger knob than the other four controls and requires over fifty revolutions to give a complete traverse of the pointer. The very high tuning ratio makes for ease of tuning especially on the short-wave ranges. Flywheel-loading of the control allows it to be "spun" for rapid tuning.

Dial calibration is in terms of frequency rather than wavelength, a feature which will be found most advantageous when using the short-wave coverage. Published frequencies for stations operating in this range are usually precise whereas the wavelengths quoted are often approximate. All broadcast and amateur bands are underlined on the scales as a further aid to rapid tuning. Broadcast bands are marked in yellow and amateur bands in white.

If the wavelength but not the frequency of a station is known, the approximate frequency can be determined quite easily by making a simple calculation. Dividing the known wavelength into 300 will give the frequency in Megahertz. For example, a station on 100 metres would appear on a frequency of 3 MHz, one on 50 metres at 6 MHz and so on.

On the long and medium wavebands, frequencies are usually given in kilohertz (kHz) and since 1 MHz = 1000 kHz, the figure in MHz obtained in the calculation above is simply multiplied by 1000 to convert it to kilohertz. 0.5 MHz for example would be 500 kHz, 1.4 MHz is 1400 kHz etc. Ranges 4 and 5 are calibrated in kilohertz.

A further scale will be found below the frequency scales, this being calibrated in arbitrary divisions 0-500. It is used in con-

junction with the small calibrated vernier (located above the tuning knob) to obtain very accurate dial settings for specific stations. The readings on the horizontal and vernier scales are combined to give a one, two, or three figure number which corresponds to the actual frequency setting in use. A list of dial settings can be compiled for those stations which attract greatest personal interest.

The small slide switch at the lower left-hand corner of the panel controls the dial illumination, a facility which will be required only on rare occasions. The switch must be held down to illuminate the scale (two lamps, one at each end), and will automatically return to the "off" position on being released. This simple precaution avoids undue drain on the batteries since the dial light consumption doubles the average current taken from the supply.

## LIST OF COMPONENTS

### RESISTORS

R1, 20, 39 :	48,000 $\Omega$
R2, 10, 37, 42, 43 :	1,000 $\Omega$
R3, 19 :	470 $\Omega$
R4, 7, 48 :	68 $\Omega$
R5, 5a, 7a, 15, 18, 20, 29, 31, 41, 51 :	100 $\Omega$
R6, 13 :	22 $\Omega$
R8, 16 :	15,000 $\Omega$
R9, 21 :	3,300 $\Omega$
R11, 49 :	390 $\Omega$
R14 :	Reference not allocated
R17, 27, 33, 38, 40 :	4,700 $\Omega$
R22, 36 :	10,000 $\Omega$
R23 :	1,500 $\Omega$
R24 :	270 $\Omega$
R25, 50 :	330 $\Omega$
R26 :	47,000 $\Omega$
R30 :	220 $\Omega$
R32 :	8,200 $\Omega$
R34 :	2,700 $\Omega$
R35 :	6,800 $\Omega$
R44, 45 :	33,000 $\Omega$
R46 :	10 $\Omega$
R47 :	560 $\Omega$
R52 :	620 $\Omega$
R53, 54 :	2.2 $\Omega$
R55 :	39 $\Omega$
R12 :	150 $\Omega$

All resistors are 10%  $\pm$ -watt except R53/54 : 5% 3-watt and R55 : 5%  $\pm$ -watt

### POTENTIOMETERS

RV1 :	10,000 $\Omega$ carbon
RV2 :	5,000 $\Omega$ carbon

### CAPACITORS

C1 :	3pF Tubular Ceramic $\pm$ 0.5pF 750V DC wkg.
C2 :	0.002uF Polystyrene $\pm$ 5% DC wkg.
C3-7, C21-25, C39-43 :	6-25pF Ceramic Trimmers.
C8, 19, 44 :	12pF Tubular Ceramic $\pm$ 10% 750V DC wkg.
C9 :	20pF Tubular Ceramic $\pm$ 10% 750V DC wkg.
C10 :	200pF Polystyrene $\pm$ 5% 125V DC wkg.
C11 :	790pF Polystyrene $\pm$ 5% 125V DC wkg.
C12, 13, 14, 26, 32, 37, 38, 78, 79, 80 :	References not allocated.
C15, 27, 48 :	3-gang air-spaced variable (3 $\times$ 12-365pF).
C16, 18, 28, 31, 33, 49, 50, 54, 59, 67, 68 :	0.1uF Polyester $\pm$ 20% 250V DC wkg.
C17 :	0.0015uF Tubular Ceramic $\pm$ 50% -25% 750V DC wkg.
C20 :	10pF Tubular Ceramic $\pm$ 10% 750V DC wkg.
C29 :	0.005uF Tubular Ceramic $\pm$ 10% 750V DC wkg.
C30 :	0.01uF Metallised Paper $\pm$ 20% 200V DC wkg.
C34 :	0.0014uF Polystyrene $\pm$ 5% 125V DC wkg.
C35 :	500pF Silvered Mica $\pm$ 2% 350V DC wkg.
C36 :	140pF Polystyrene $\pm$ 5% 125V DC wkg.
C45 :	40pF Tubular Ceramic $\pm$ 10% 750V DC wkg.
C46, 64 :	0.047uF Polyester $\pm$ 20% 250V DC wkg.
C47 :	0.007uF Polystyrene $\pm$ 5% 125V DC wkg.
C51, 52, 56, 57 :	300pF Polystyrene $\pm$ 5% 60V DC wkg.
C53, 58, 69, 71, 82 :	10uF Tubular Electrolytic $\pm$ 50% -10% 16V DC wkg.
C55, 60, 65, 66 :	0.01uF Polyester $\pm$ 20% 250V DC wkg.
C61, 70, 72, 73 :	100uF Tubular Electrolytic $\pm$ 100% -20% 15V DC wkg.
C62 :	250pF Polystyrene $\pm$ 5% 60V DC wkg.
C63 :	0.01uF Metallised Paper $\pm$ 20% 150V DC wkg.
C74 :	0.001uF Polystyrene $\pm$ 5% 125V DC wkg.
C75, 77 :	200uF Tubular Electrolytic $\pm$ 100% -20% 6V DC wkg.
C76 :	0.022uF Polyester $\pm$ 20% 250V DC wkg.
C81 :	600uF Tubular Electrolytic $\pm$ 100% -20% 16V DC wkg.

ALL TRIMMERS ARE 5-15%

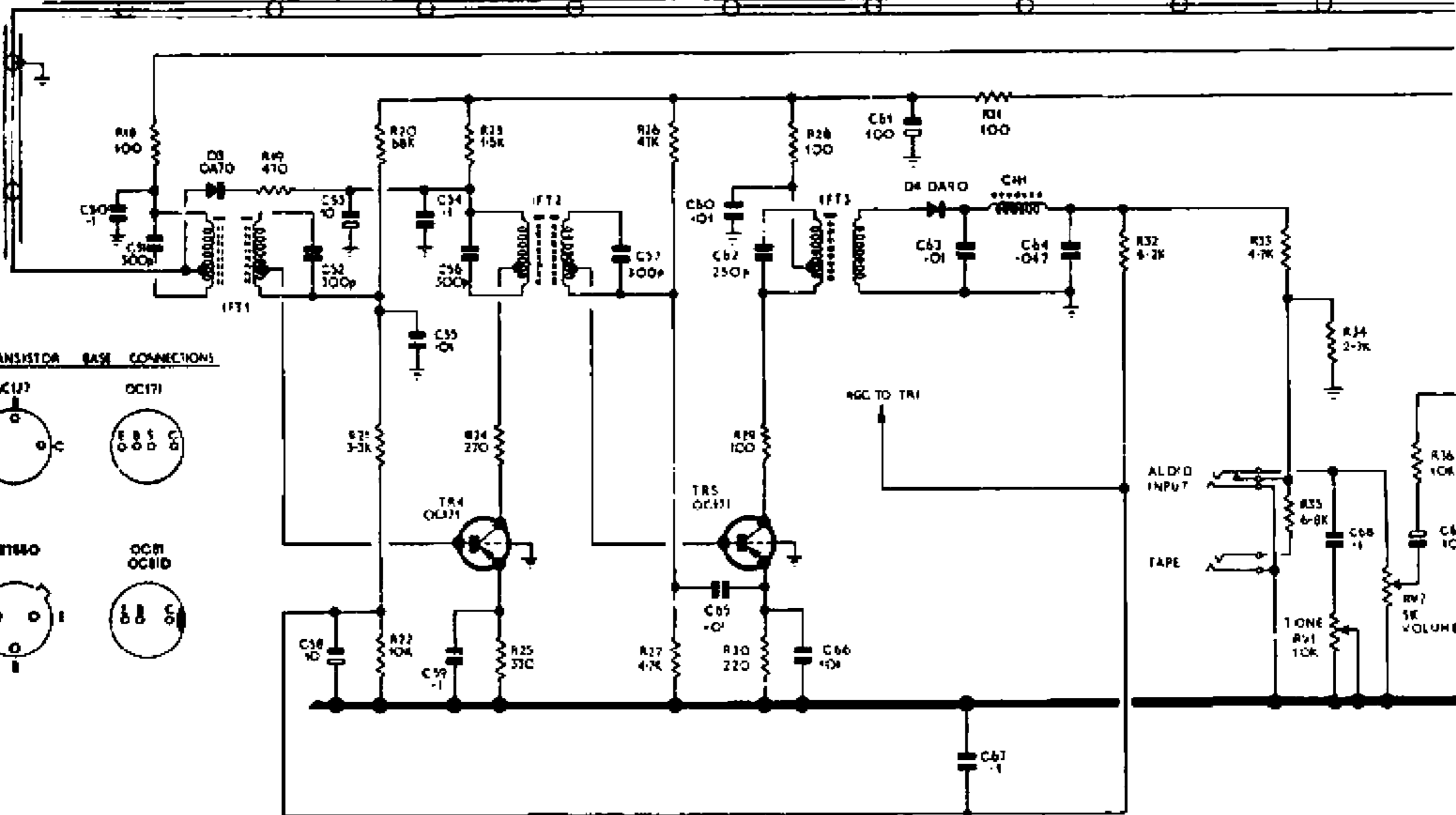
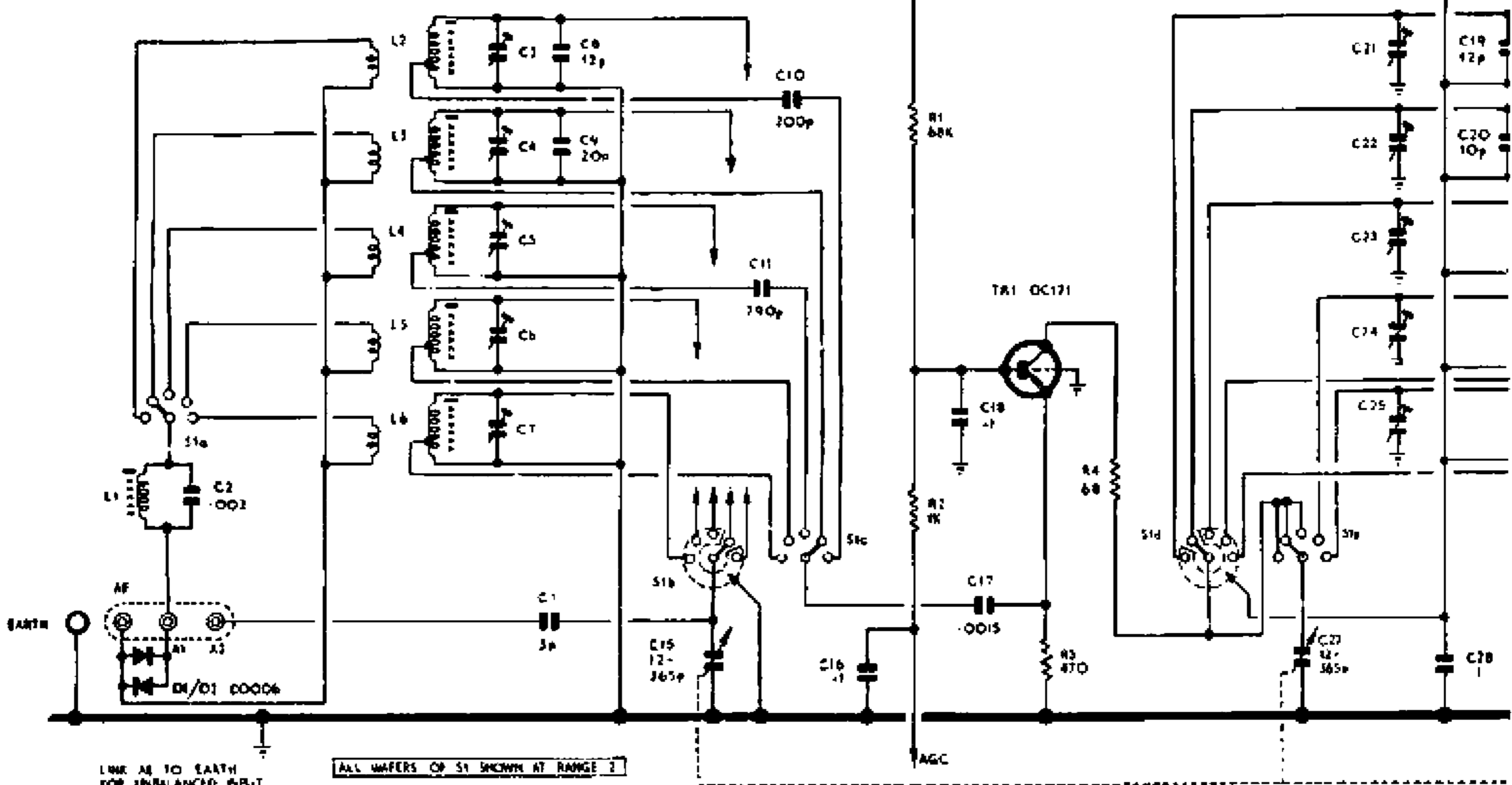

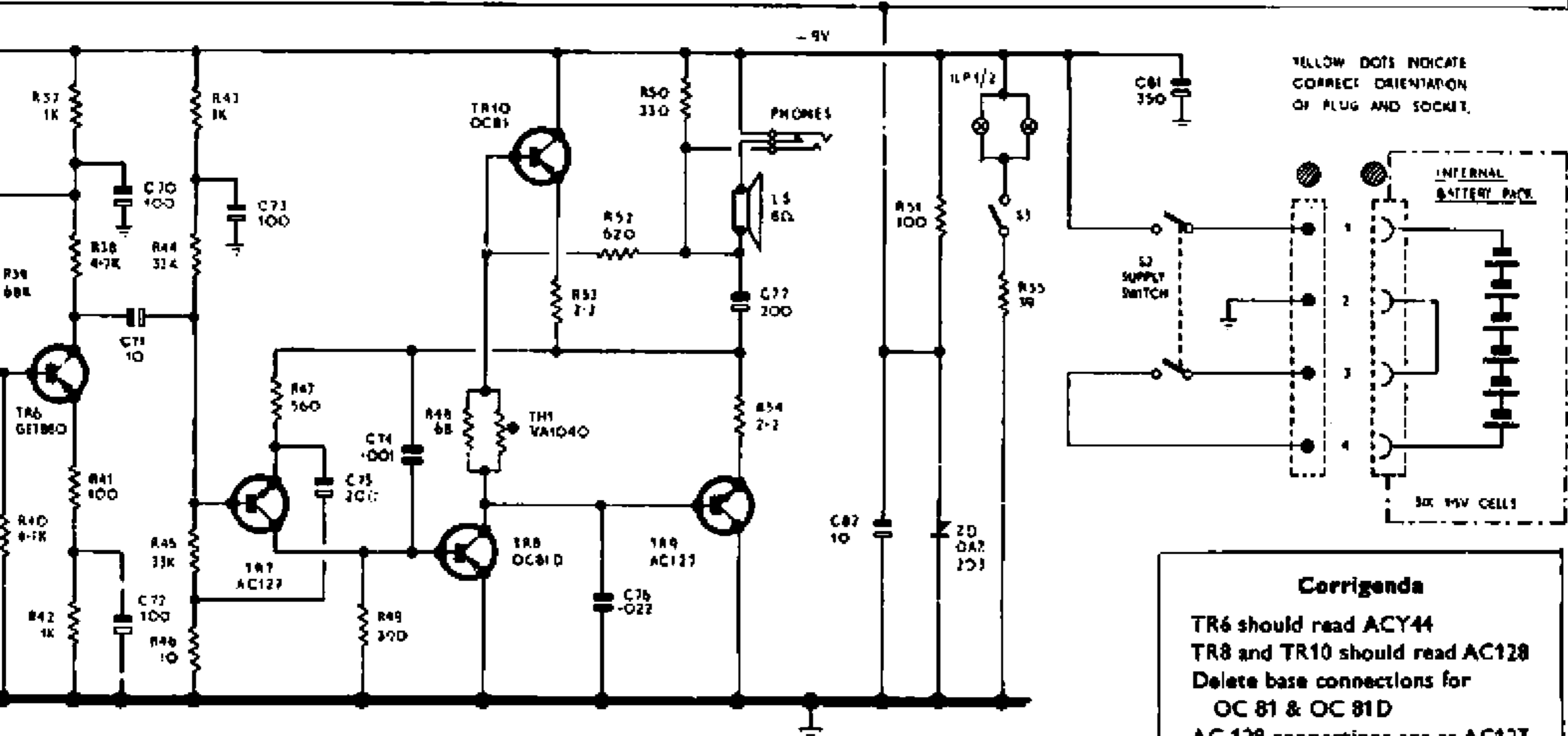
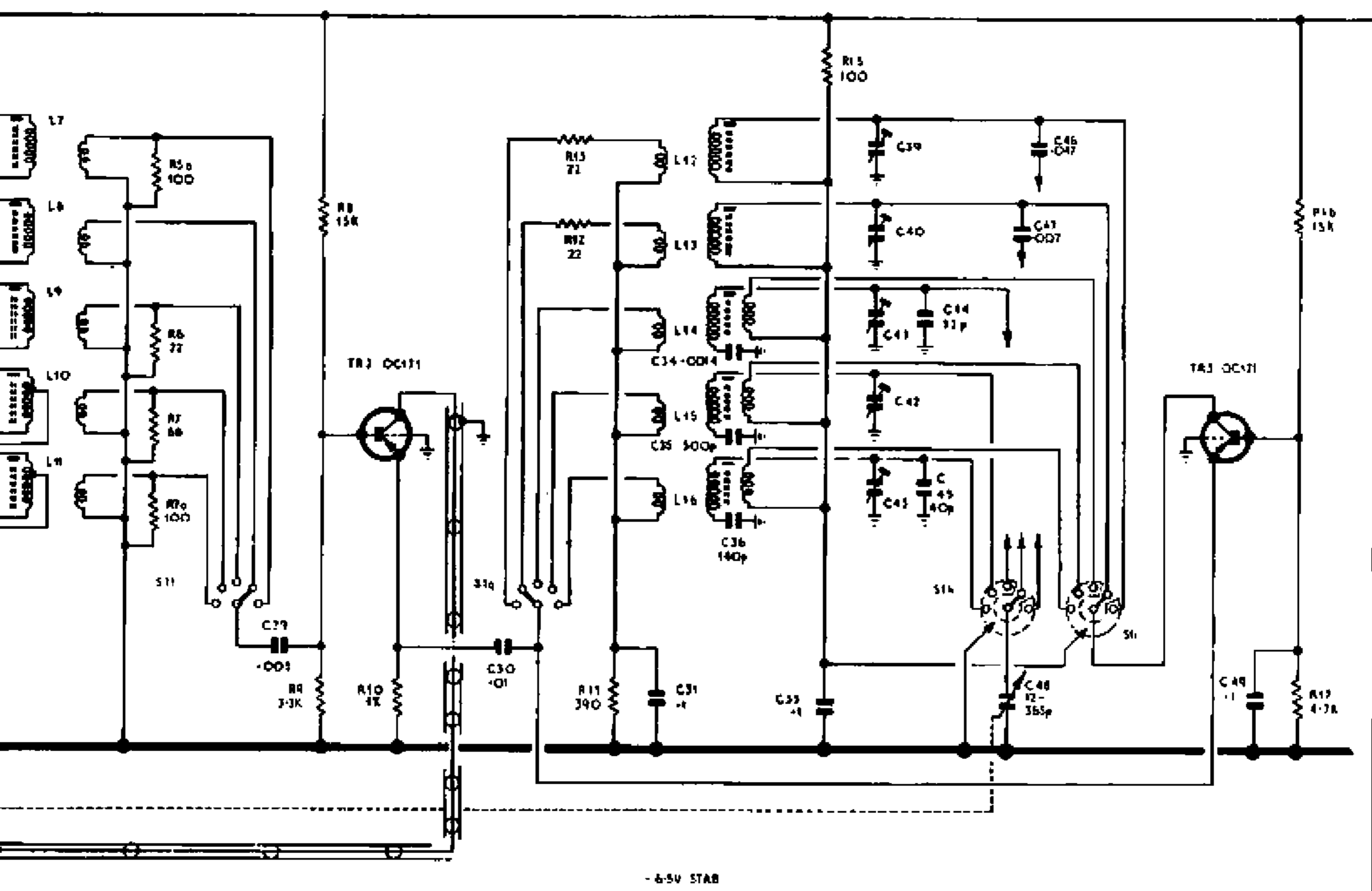

YELLOW DOTS INDICATE CORRECT ORIENTATION OF PLUG AND SOCKET.

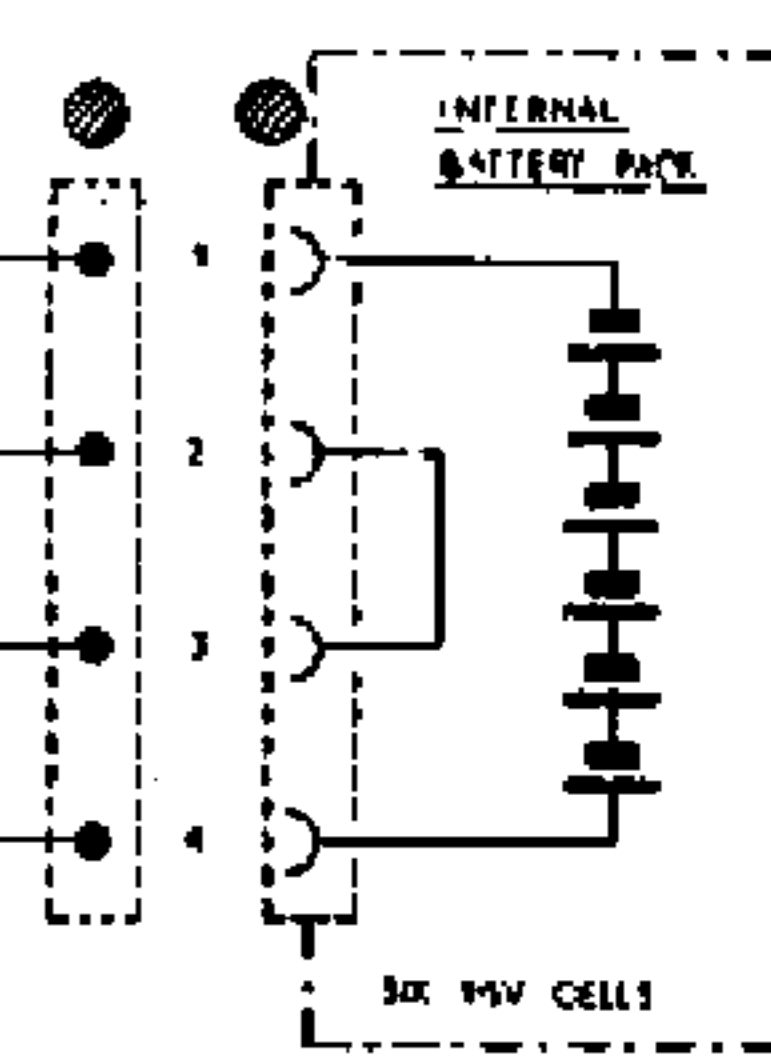

**Corrigenda**

- TR6 should read ACY44
- TR8 and TR10 should read AC128
- Delete base connections for OC 81 & OC 81D
- AC 128 connections are as AC127
- R12 should read 150Ω
- C81 should read 400uF
- GET880 bating should read ACY44

**MODEL EB37**

# MAINTENANCE

## General

The EB37 receiver should require very little in the way of routine maintenance apart from replacement of the batteries from time to time. If a fault should develop, check first that it is not an obvious one such as poor contact in the battery connector due to this not being pushed fully into the socket. Other simple faults which may occur are broken or shorting aerial connections and, in the case of a receiver operating from the mains with a Power Unit Type 924—a blown fuse.

If the fault cannot be traced, take the receiver to the nearest EDDYSTONE Agent who will rectify the trouble at reasonable cost. A list of Agents can be obtained from the Sales and Service Dept., at our usual address.

If there is no Agent in your district the set can be taken to any reputable dealer but you are then advised to take this sheet with the set because the engineer concerned may not be familiar with Eddystone equipment. The sheet contains information which will assist him in locating the fault and will help to ensure that the receiver is serviced in the shortest possible time. Receivers can be returned to the manufacturer but prior arrangements should be made by writing first to the Sales and Service Dept.

## Removing the Cabinet.

1. Remove the battery container (or power unit) by unscrewing the two knurled retaining screws and disengaging the internal connector. In the case of a mains operated receiver, make sure that the supply is disconnected before taking out the power unit.
2. Remove the four cabinet retaining screws located at the rear.
3. Free the cabinet from the panel by applying pressure with the fingers between the inner edge of the cabinet and the ends of the strip which supports the IF printed board (near top edge of cabinet). If stiff, use screwdriver as lever in slots at lower front edge of cabinet.
4. Slide cabinet away from panel.

## Dial lamps.

Faulty dial bulbs can be changed by prising the holders free from the rubber mounting grommets at the extreme ends of the dial. Replacement bulbs should be of the L.E.S. type rated at 6V, 50mA

## Fuses.

These are fitted only for mains operation of the receiver and are located inside the power unit. The mains input is fused at 100mA

and the 9V output feeding the receiver at 500mA. Standard  $1\frac{1}{2}'' \times \frac{1}{4}''$  cartridge fuses are required as replacements.

## Re-stringing the pointer drive cord.

It is most unlikely that trouble would be experienced with the high quality cord used on the EB37 receiver. If a breakage should occur however, a length of suitable cord can be obtained from the manufacturer. No difficulty should be encountered in fitting the replacement if the instructions given below are followed carefully step by step. Right-hand and left-hand are as viewed from the rear of the set.

1. Remove the existing cord and set the tuning gang to full mesh.
2. Tie a double knot in one end of the replacement cord and feed the cord through the hole provided in the left-hand drive pulley with the knot on the inside of the rim.
3. Wind approximately one and a half turns anti-clockwise round the drive pulley and then pass the cord under and over the left-hand guide pulley.
4. Pass the cord across the dial from left to right and then, while holding the free end of the cord in tension, rotate the tuning control to fully unmesh the tuning gang. This operation will wind just over three complete turns of cord onto the left-hand drive pulley and tension must now be maintained to prevent the cord from slipping out of the pulley groove.
5. Pass the cord clockwise round the jockey pulley (right-hand side of receiver) and then back across to the right-hand drive pulley. Feed the cord into the pulley groove and then through the hole in the rim. Increase tension on the cord until the outer rim of the jockey pulley takes up a position level with the nearest edge of the panel handle retaining screw. Mark the cord with a pencil at the point where the retaining knot must be tied.
6. Free the cord from the jockey pulley and, while maintaining tension, draw the cord through the hole in the right-hand drive pulley until it tightens on the left-hand guide pulley.
7. Tie a double knot in the position marked in (5) above and then cut off the surplus cord. Feed the cord back through the hole and replace in position round the jockey pulley.
8. Set the tuning gang to full mesh and slide the pointer to "0" on the logging scale. Attach the cord to the pointer in this position making sure that the cord passes under the two outer prongs at the rear of the pointer carrier
9. Check the drive for free and normal operation. Verify scale accuracy by tuning to one of the frequency standard stations (2.5, 5, 10, 15, 20 MHz.)

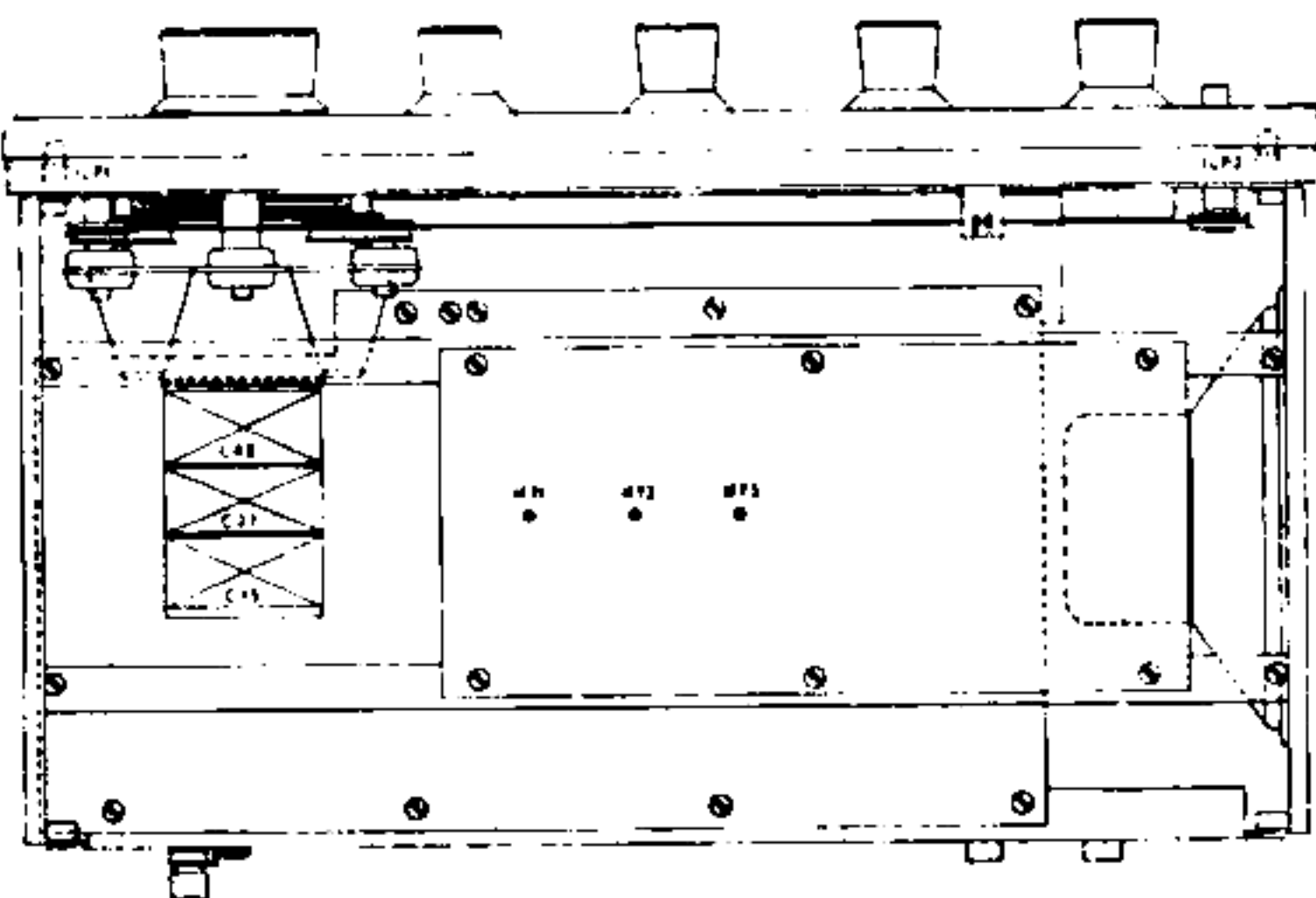

Plan view of Model EB37 Receiver

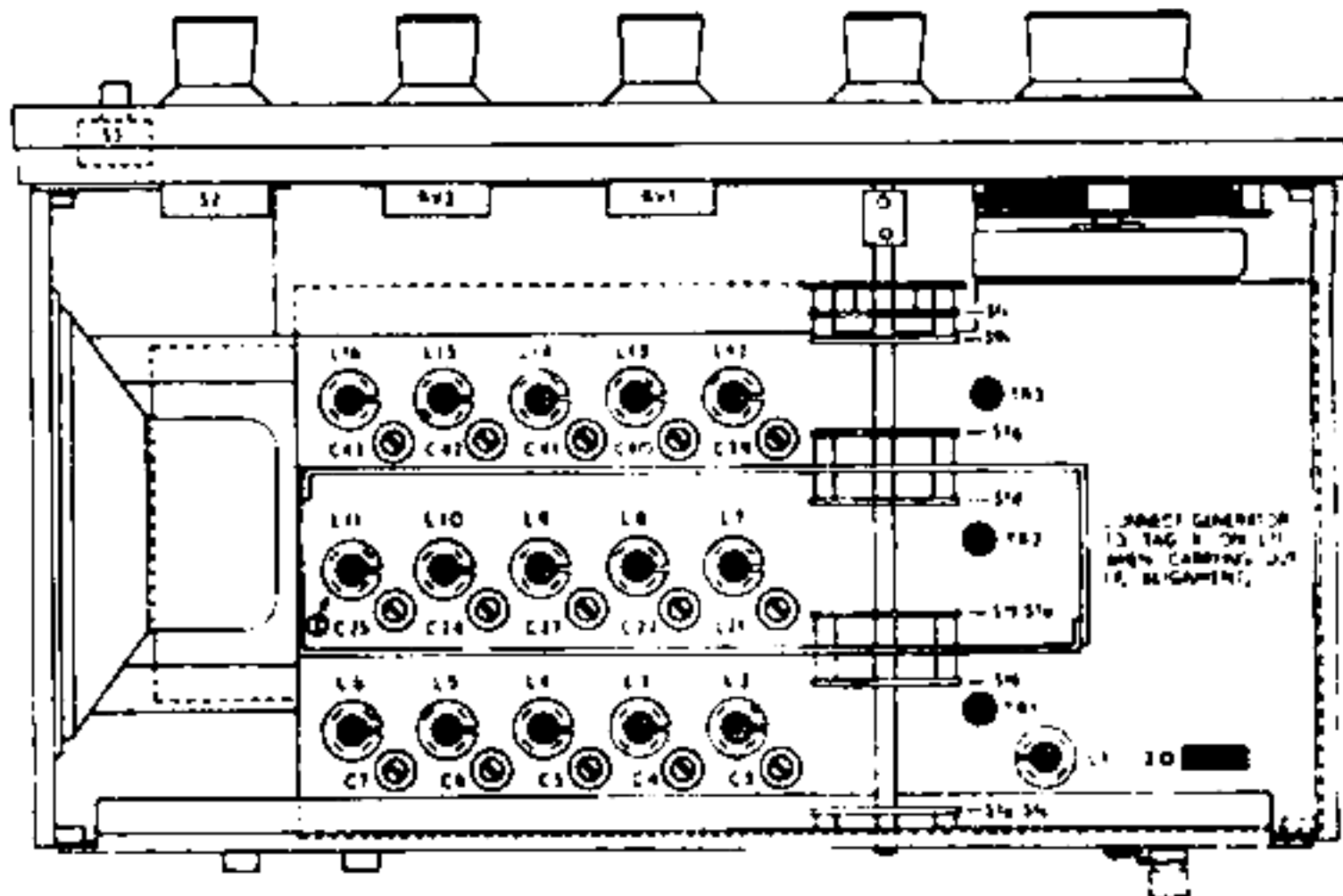

Underside view of Model EB37 Receiver

# RE-ALIGNMENT

Initial factory alignment of the receiver should hold for a long period and further adjustment should not be attempted unless there is a clear indication that this course of action is in fact essential. An adequate range of test equipment is required for accurate re-alignment (see below) and the task should be performed only by individuals having a skilled knowledge of the procedures involved.

Sensitivity figures quoted in the instructions which follow are based on the assumption that the battery pack is delivering a supply voltage of 9V. All dust cores and trimmers are self-locking.

The following items of test equipment are required for re-aligning the EB37 receiver:—

Signal generator(s) covering the intermediate frequency of 465 kHz and the signal frequency ranges 150—350 kHz and 550 kHz—30 MHz. Output impedance  $50/75\Omega$ , modulation 30% at 400 Hz.

Modulated crystal-controlled harmonic-generator providing 100 kHz markers up to 7.5 MHz and 1 MHz markers up to 22 MHz.

Output meter matched to  $8\Omega$  with plug to mate with telephone socket on panel.

Trimming tools:— Miniature insulated screwdriver with  $\frac{1}{16}$ " blade, small metal-tipped insulated screwdriver and a Neosid Type H.S.I. hexagonal core adjuster

## Re-alignment of the IF Stages

First locate and remove the four screws holding the two angle strips on which the IF printed wiring board is mounted. Rotate the board through 90° and temporarily secure in this position using two of the screws just removed. Access to both ends of the IF Transformers is now possible and the receiver can be placed on its left-hand side-plate to permit connection of the generator output lead to the Range 5 Mixer coil L11 (see underside view of receiver). Generator output impedance should be arranged to match  $50\Omega$ , the earthy lead being clipped to the screen adjacent to the coil.

Short out the forward section of the tuning gang (C48) to disable the Local Oscillator and connect the output meter to the telephone socket on the panel. The speaker circuit is interrupted by insertion of the plug and the meter will therefore indicate true output power. Switch on the generator, allow it adequate time to stabilise against drift and set the receiver controls as follows:—

Range Switch .. Range 5.      Volume .. Maximum.  
Tuning .. .. 350 kHz.      Tone .. .. Fully c/wise.

Tune the signal generator to 465 kHz (with modulation 30% at 400 Hz) and then set the attenuator to give a reading of approximately 50mW on the output meter. Peak the cores in IFT1, IFT2 and IFT3 for maximum output remembering that the first two transformers are double-tuned and the final transformer has a single core only. All cores should be set to the "outer" peak, each adjustment being repeated several times to ensure accurate alignment.

On completion of the adjustments detailed above, re-set the attenuator for an output reading of 50mW and check that the overall IF sensitivity is of the order 4uV. If the gain appears to be on the low side, commence investigation by taking sensitivity readings from the bases of TR4 and TR5. The live generator lead must be blocked with a capacitor of some 0.05uF while making this check which should reveal sensitivities of the order 35 uV and 1mV respectively for an output of 50mW.

A low reading from the base of TR5 almost certainly indicates a fault in the audio section of the receiver. The appropriate stages can be tested by introducing a 1000Hz signal via the Audio Input socket at the rear. An input of approximately 5mV should produce 50mW output.

Once the IF alignment has been completed, disconnect the generator(s) and output meter, remove the shorting link from C48 and re-fit the IF board in its normal position.

## RF Alignment.

The first step in this part of the alignment procedure is a check on the overall calibration accuracy. Proceed as follows:—

Connect the output of the harmonic generator to the "AI" and "AE" sockets with the shorting link in place between the "AE" socket and the EARTH terminal. Set the generator to provide modulated 1 MHz markers and then tune across the whole of Range 1, checking the scale accuracy at each Megahertz point. Accuracy should be within 1% (i.e. 200 kHz at 20 MHz, 100 kHz at 10 MHz, 20 kHz at 2 MHz etc.). Re-alignment of the Local Oscillator circuits should be considered necessary only if the error observed is greater than this.

Repeat the check on Range 2 and then select Range 3. The 100 kHz markers can be introduced on this range to permit checking at 500 kHz intervals. On Ranges 4 and 5, check each 100 kHz point.

Errors in excess of 1% on any range should be rectified by carrying out normal tracking procedure, taking care to repeat all adjustments several times to nullify interaction between the appropriate trimmer and core. Alignment frequencies and adjustments are given in Table 1.

Table 1

## OSCILLATOR ALIGNMENT FREQUENCIES AND ADJUSTMENTS

Range	Freq.	Trimmer	Freq.	Core
1	20.0 MHz	C39	8.0 MHz	L12
2	8.0 MHz	C40	3.6 MHz	L13
3	3.5 MHz	C41	1.5 MHz	L14
4	1400 kHz	C42	550 kHz	L15
5	330 kHz	C43	160 kHz	L16

On completion of any re-alignment of the Local Oscillator circuits, disconnect the harmonic generator and connect the signal generator in its place prior to commencing re-alignment of the RF (Aerial) and Mixer circuits. The generator output impedance should be arranged to match  $75\Omega$  when aligning Ranges 1—3 and  $400\Omega$  for Ranges 4 and 5. Modulation should be set to 30% at 400 Hz and the output meter should be connected to the telephone socket as during IF alignment.

Adjustments are made at the same frequencies employed for oscillator alignment but using the trimmers and cores listed in Table 2. As with oscillator alignment, each adjustment should be repeated several times to cancel the inevitable interaction between trimmer and core. The aerial input circuits should be adjusted for best signal/noise ratio.

Table 2.

## RF/MIXER ALIGNMENT FREQUENCIES AND ADJUSTMENTS

Range	Trimmer			Core		
	Freq.	Aerial	Mixer	Freq.	Aerial	Mixer
1	20.0 MHz	C3	C21	8.6 MHz	L2	L7
2	8.0 MHz	C4	C22	3.6 MHz	L3	L8
3	3.5 MHz	C5	C23	1.5 MHz	L4	L9
4	1400 kHz	C6	C24	550 kHz	L5	L10
5	330 kHz	C7	C25	160 kHz	L6	L11

The IF rejector coil L1 should be adjusted when aligning Range 4, the procedure being as follows:—

Tune the receiver to 550 kHz (low frequency alignment point) and the generator to the intermediate frequency of 465 kHz. Increase output from the generator until an indication is obtained on the output meter. Adjust the rejector coil for *minimum* signal. Re-tune the generator to 550 kHz, reduce its output and check the adjustment of L5 for *maximum* signal. Repeat both checks to ensure accurate alignment of the two circuits.

Finally, carry out a check on the overall sensitivity at the mid-band frequency on each range. With the generator properly matched sensitivities of the order 5 $\mu$ V or better should be realised on the three higher frequency ranges. On Ranges 4 and 5 the sensitivity is a little lower being in the region of 15 $\mu$ V or better. All sensitivities are quoted for a signal/noise ratio of 15dB and an output of 50mW in 8 $\Omega$ .

## VOLTAGE ANALYSIS

Typical voltage readings for each stage are given in the Table which follows. All readings were taken under no-signal conditions on Range 5 using a testmeter with a sensitivity of 20,000 $\Omega$ /V. All readings are negative w.r.t. earth and a tolerance of 20% should be allowed.

Reference	Collector	Base	Emitter
TR1	6.1V	0.95V	0.65V
TR2	6.3V	1.25V	1.3V
TR3	6.1V	1.5V	1.5V
TR4	5.0V	1.15V	0.95V
TR5	8.0V	0.7V	0.45V
TR6	6.4V	0.5V	0.45V
TR7	0.16V	4.2V	4.6V
TR8	4.7V	0.16V	—
TR9	—	4.8V	4.9V
TR10	9.0V	5.0V	4.9V

## SPARES

The following list details all major spares for the EB37 receiver. The Serial No. of the receiver must be quoted in all correspondence and enquiries should be directed to the "Sales and Service Dept".

### Inductors, Transformers etc.

L1	465 kHz IF Rejector coil	.. .. .	D3204
L2	Range 1 RF (Aerial) coil	.. .. .	D3517
L3	Range 2 RF (Aerial) coil	.. .. .	D3191
L4	Range 3 RF (Aerial) coil	.. .. .	D3192
L5	Range 4 RF (Aerial) coil	.. .. .	D3193
L6	Range 5 RF (Aerial) coil	.. .. .	D3518
L7	Range 1 Mixer coil	.. .. .	D3519
L8	Range 2 Mixer coil	.. .. .	D3196
L9	Range 3 Mixer coil	.. .. .	D3197/1
L10	Range 4 Mixer coil	.. .. .	D3198
L11	Range 5 Mixer coil	.. .. .	D3520
L12	Range 1 Oscillator coil	.. .. .	D3521

L13	Range 2 Oscillator coil	.. .. .	D3201
L14	Range 3 Oscillator coil	.. .. .	D3202
L15	Range 4 Oscillator coil	.. .. .	D3203
L16	Range 5 Oscillator coil	.. .. .	D3522
IFT1	1st 465 kHz IF transformer	.. .. .	6653P
IFT2	2nd 465 kHz IF transformer	.. .. .	6654P
IFT3	3rd 465 kHz IF transformer	.. .. .	6655P
CH1	Detector filter choke	.. .. .	D2414/1

### Semiconductors.

TR1	RF Amplifier	.. .. .	Mullard OC171
TR2	Mixer	.. .. .	Mullard OC171
TR3	Local Oscillator	.. .. .	Mullard OC171
TR4	1st IF Amplifier	.. .. .	Mullard OC171
TR5	2nd IF Amplifier	.. .. .	Mullard OC171
TR6	1st AF Amplifier	.. .. .	Mullard ACY 44
TR7	2nd AF Amplifier	.. .. .	Mullard AC127
TR8	AF Driver	.. .. .	Mullard AC128
TR9	Complementary	.. .. .	Mullard AC127
TR10	AF Output	.. .. .	Mullard AC128
D1/D2	Overload Protector	.. .. .	Lucas DD006's
D3	AGC Attenuator	.. .. .	Mullard OA70
D4	Detector/AGC	.. .. .	Mullard OA90
D5 (ZD)	Zener Stabiliser	.. .. .	Mullard OAZ203

### Miscellaneous.

Range Switch:	Clicker mechanism	.. .. .	5625P
	Wafers Sla/c, Sle/f Slg	.. .. .	5393P
	Wafers Slb, Sld, Slh, Sli	.. .. .	5404P
Supply Switch (S2)		.. .. .	8425P
Dial Light Switch (S3)		.. .. .	6918P
Volume Control (RV2)		.. .. .	6860P
Tone Control (RV1)		.. .. .	6860/IP
Dial Bulbs (L.E.S., 50mA, 6.7mm.)		.. .. .	6659P
Dial Bulb Holder		.. .. .	6600P
Phone Jack		.. .. .	6660P
Loudspeaker (8 $\Omega$ , 5-inch round)		.. .. .	7348P
Drive Assembly		.. .. .	LP2864
Pointer Assembly		.. .. .	D3215
Dial Glass (Calibrated)		.. .. .	D4526
Knobs:	Tuning	.. .. .	D3613/3
	Wavechange	.. .. .	
	Vol., Tone, Supply	.. .. .	D3617/4
Tape and			
AF Input sockets (combined assembly)		.. .. .	7841P
Tape Plug (white)		.. .. .	6943P
AF Input plug (black)		.. .. .	6943/1P
3-gang Tuning Capacitor		.. .. .	6528P
Flexible coupler		.. .. .	D2017
Shorting Plug (AE)		.. .. .	D3210
Earth Terminal		.. .. .	6371P
Aerial Socket Strip		.. .. .	D3209

### Manufacturers :

# EDDYSTONE RADIO LTD.

MEMBER OF MARCONI COMMUNICATIONS SYSTEMS LTD.

ALVECHURCH ROAD, BIRMINGHAM B31 3PP

Telephone : 021-475 2231

Cables: EDDYSTONE, BIRMINGHAM

Telex : 337081

