

UNITED MOTORS

Chevrolet Pushbutton Model 987575

(Continued from page 158, over)

ARCHIEF  
DOCUMENTATIEDIENST  
NVHR

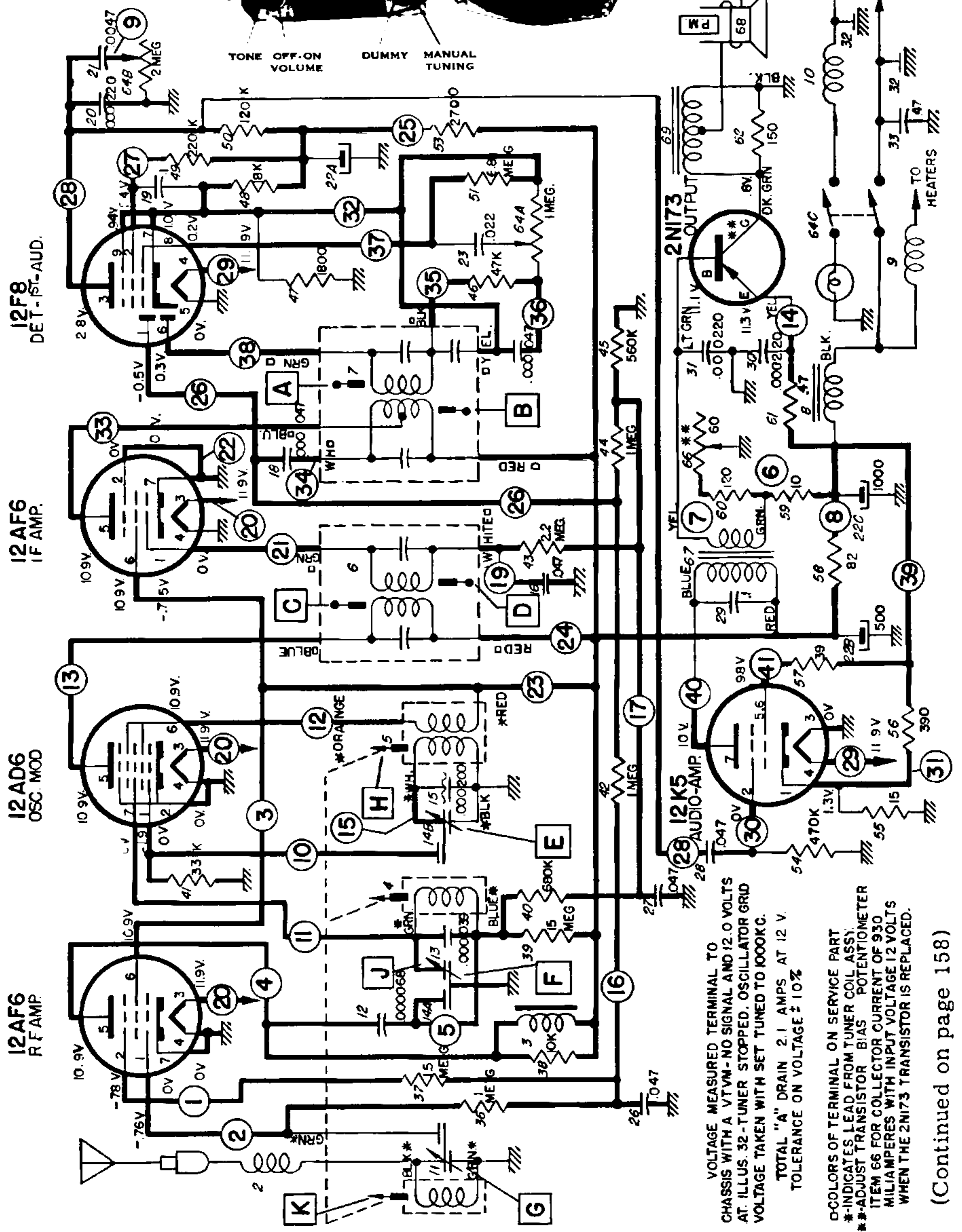
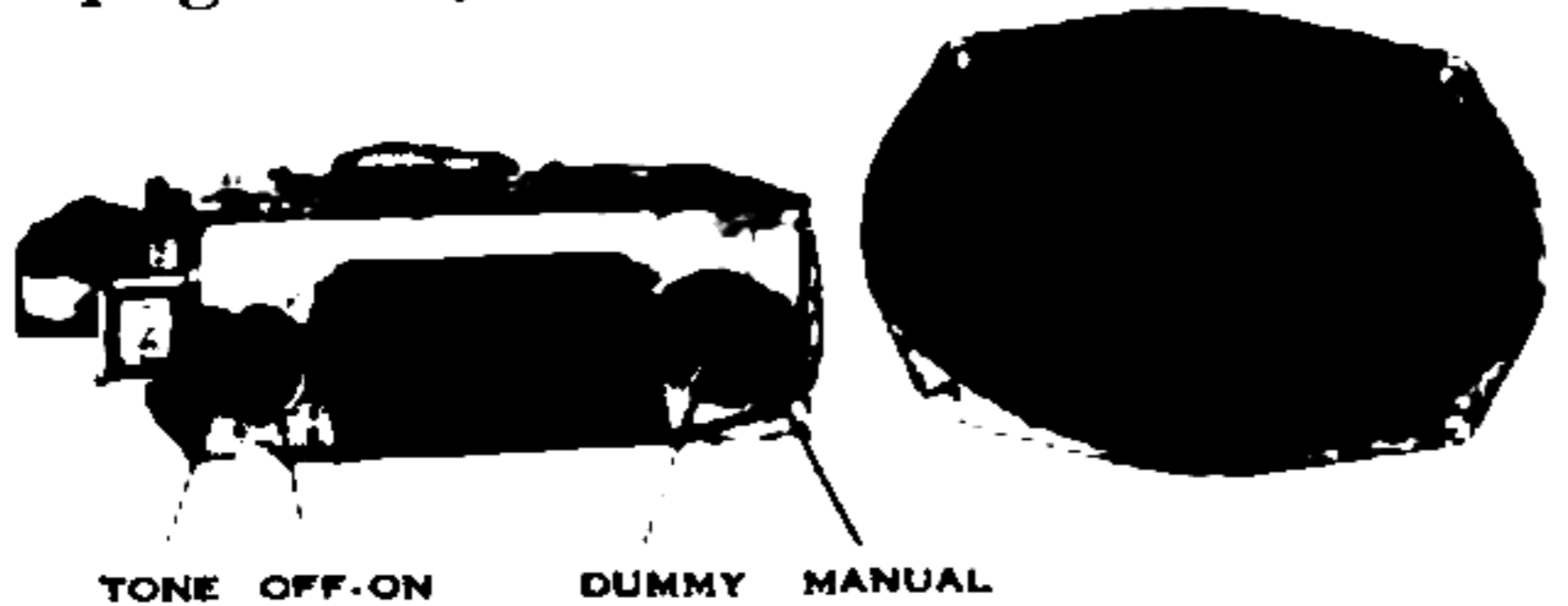

VOLTAGE MEASURED TERMINAL TO CHASSIS WITH A VTVM - NO SIGNAL AND 12.0 VOLTS AT ILLUS. 32-TUNER STOPPED. OSCILLATOR GRID VOLTAGE TAKEN WITH SET TUNED TO 1000KC.  
TOTAL "A" DRAIN 2.1 AMPS AT 12 V. TOLERANCE ON VOLTAGE ± 10%

COLORS OF TERMINAL ON SERVICE PART \*-INDICATES LEAD FROM TUNER COIL ASSY. \*-ADJUST TRANSISTOR BIAS POTENTIOMETER ITEM 66 FOR COLLECTOR CURRENT OF 930 MILLIAMPERES WITH INPUT VOLTAGE 12 VOLTS WHEN THE 2N173 TRANSISTOR IS REPLACED.

(Continued on page 158)

RADIO BLOWS FUSES

If the radio blows fuses, check for a shorted transistor. If the transistor is O.K. check for a short in the radio supply circuit.

Signal trace, using isolated (capacitor in lead) signal generator or "signal tracer." A strong audio signal injected at the 12K5 tube plate, pin #7, should be heard in the case of a dead radio. (A quick check of the audio stage can be made with the radio warmed up by pulling out the 12K5 tube and listening for a "click". If the "click" is heard the transistor stage is working).

UNITED MOTORS Chevrolet 987575 (Continued from page 157)

TROUBLE SHOOTING THE OUTPUT STAGE

A quick way to determine that the 2N173 is conducting can be made by checking the collector voltage, from transistor case to the radio case. If no voltage is present the transistor is not conducting or the transistor heat radiator is grounded to the radio case. If the voltage at the collector is higher than listed the transistor is conducting too heavily (check with milliammeter) or the output transformer is open. The amount of current the transistor conducts is determined by the voltages at each element, the resistor in the base and emitter circuits, the input transformer secondary resistance, and the transistor itself. The most common defect in the transistor is an internal

short between emitter and collector. To check for this, use the following procedure:

1. Unsolder base and emitter leads from the circuit.
2. Set ohmmeter on the "R x 1" scale (no other scale should be used).
3. Place negative lead of ohmmeter (polarity refers to internal ohmmeter battery) on collector, and positive lead on the emitter.
4. The transistor is shorted if reading is "0".

If a transistor is replaced, the "bias" adjustment should be made for the new transistor. Insert a milliammeter in the collector lead and adjust the bias control for a collector current of 930 ma.

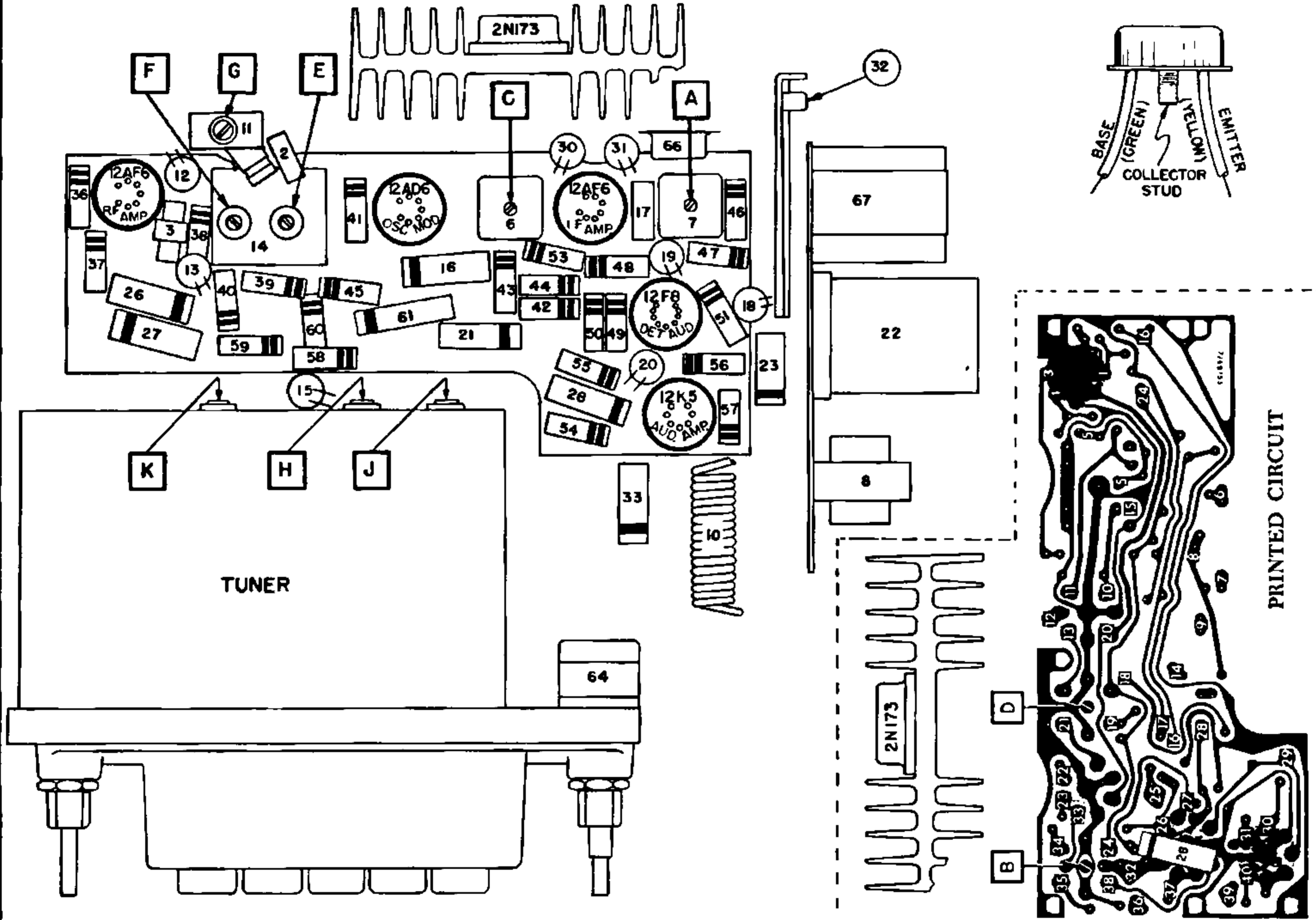

PARTS LAYOUT—TUBE VIEW

ALIGNMENT PROCEDURE

Steps	Series Capacitor or Dummy Antenna	Connect Signal Generator to	Signal Generator Frequency	Tune Receiver to	Adjust in Sequence For Max. Output
1	0.1 Mfd.	12AD6 Grid (Pin #7)	262 KC	High Frequency Stop	A, B, C, D
2	0.000068 Mfd.	Antenna Connector	1615 KC	High Frequency Stop	*E, F, G
3	0.000068 Mfd.	Antenna Connector	640 KC	Signal Generator Signal	J, K
4	0.000068 Mfd.	Antenna Connector	1615 KC	High Frequency Stop	F, G
5	0.000068 Mfd.	Antenna Connector	900 KC	Signal Generator Signal	L**

\*Before making this adjustment check mechanical setting of oscillator core "H." The rear of the core should be 1 5/8" from the mounting end of the coil form. (This measurement is readily made by inserting a suitable plug in the mounting end of the coil form.) Core adjustment should be made with a non-metallic screw driver.

\*\*L is the pointer adjustment which is on the connecting link, between the pointer assembly and core guide bar. It should be adjusted so that when looking directly at the dial the pointer is on the 1100 KC mark. This setting is to give the correct relationship between the pointer and the dial when the radio is installed in a car.

With the radio installed and the car antenna plugged in adjust the antenna trimmer "G" for maximum volume with the radio tuned to a weak station between 600 and 1000 KC (see sticker on case.)