

EKCO PB199 WITH MOTOR TUNING

CIRCUIT.—It is easier to understand the circuit if it is appreciated at the outset that V3 and V5 are used solely for automatic frequency correction. Apart from these and their associated circuits the receiver is a comparatively straightforward superhet.

The principles of automatic frequency control were explained in the *Service Engineer* of March 5, 19 and 26. Briefly its object is to correct electrically for any mechanical tuning error introduced by the motor drive. This is done by shifting the oscillator frequency so that the correct I.F. is produced even though the oscillator stage does not originally produce the exact required frequency. V3 is the corrector valve which controls the oscillator frequency, and V5 is the discriminator which is operated by any off-tune I.F. signal and produces a current which increases or decreases the capacity effect of V3 as required.

Radio Section.—The aerial input to the grid of V1, an H.F. pentode operating as an amplifier, is via a set of transformer aerial coils on all three wavebands. There is a condenser C51 across the primary medium wave winding.

V1 is coupled to V2, a triode hexode frequency changer, by means of further H.F. transformers. The output of V2 passes via an iron-cored I.F. transformer, provided with a third winding that gives variable selectivity controlled by a switch, to the I.F. amplifier V4, an H.F. pentode. V1, V2 and V4 are A.V.C. controlled. The cathode circuits contain resistors that

provide a standing bias, and, in the cases of V1 and V2, there are further resistors controlled by shorting switches to regulate sensitivity.

Another I.F. transformer provides the coupling between V4 and the demodulating diode of V6, a double diode triode. The potentials from the demodulating diode load of V6 feed both the visual tuning indicator and the grid of the triode section of V6.

The other diode of V6, fed by a coupling condenser C32 and with load resistors R17 and R18, provides the impulse operating the A.V.C. network.

A manual volume control in the grid circuit of V6 is tone compensated by C54, whilst potentials obtained from an inverse feed-back circuit R35, R44 and C36—fed from a third winding on the output trans-

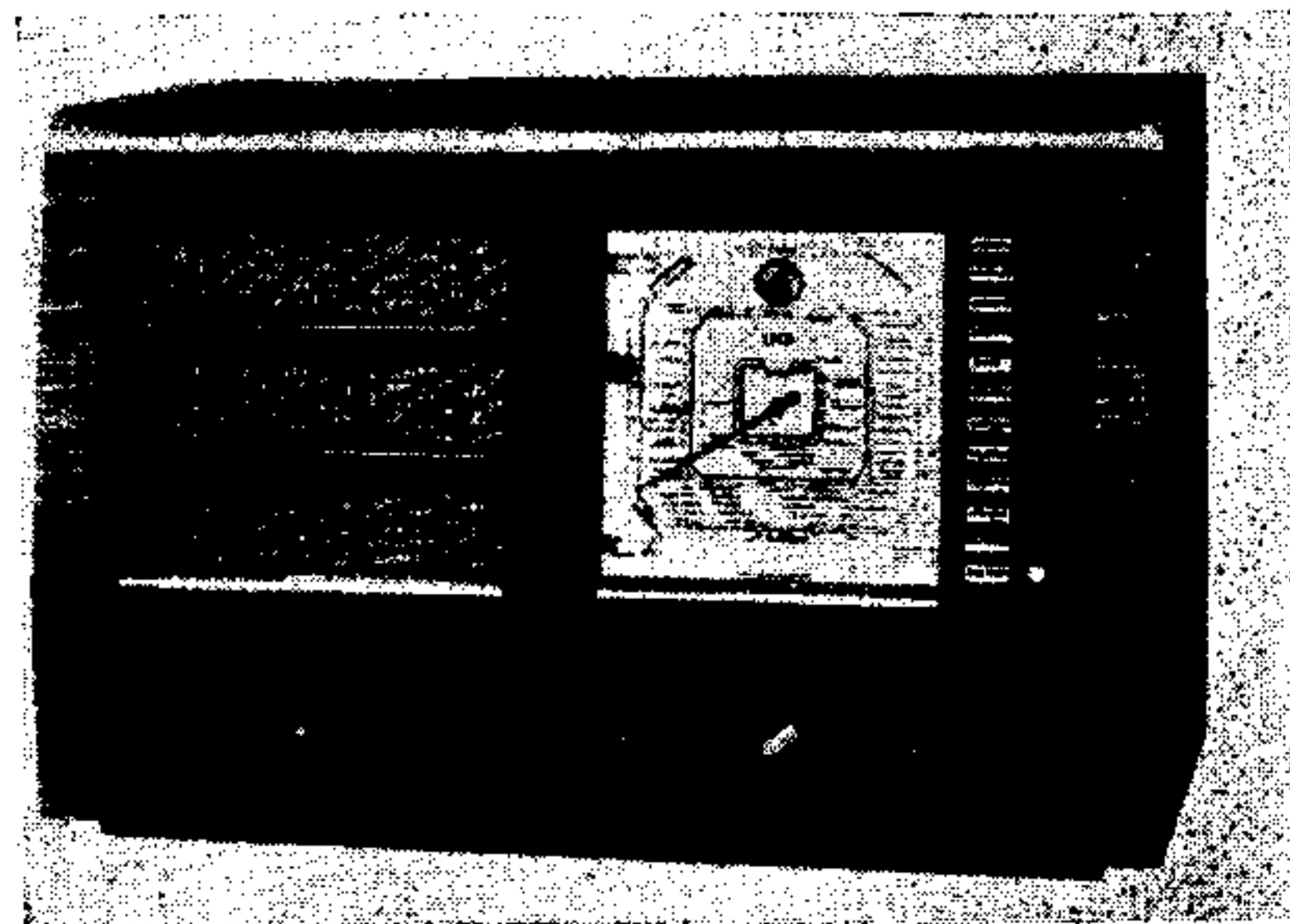

The Ekco PB 199 is a five-valve, plus rectifier, A.C. superhet with motorised automatic tuning and two additional valves for automatic frequency control.

former to the lower end of the manual volume control—emphasise the bass response.

V6 is resistance capacity coupled to the output valve V7, an output pentode. A

RESISTANCES

R.	Purpose.	Ohms.	R.	Purpose.	Ohms.
1	V1 cathode bias (part)	100	24	Negative feed-back injection resistance	500
2	V1 cathode bias (part)	1,000	25	V6 and T.I. cathode bias	1,000
3	V1 screen decoupling	10,000	26	V3 grid decoupling	1 meg.
4	V1 anode decoupling	1,000	27	T.I. anode feed	2 meg.
6	V2 cathode bias (part)	200	28	T.I. grid leak	25,000
7	Osc. grid leak	25,000	29	V5 cathodes potr. (part)	500,000
8	V3 cathode bias (part)	300	30	V5 cathodes potr. (part)	500,000
9	V1 A.V.C. decoupling	1 meg.	32	H.T. line decoupling (part)	700
10	V3 cathode bias	1,200	33	H.T. line decoupling (part)	700
11	Corrector valve network	15,000	34	V6 anode load	50,000
12	Corrector valve network	25,000	35	Negative feed-back filter	15,000
13	Corrector valve network	25,000	36	V7 grid leak	250,000
14	V3 grid decoupling	100,000	37	T.I. anode feed	80,000
15	V3 anode decoupling	15,000	38	V7 cathode bias	200
16	V2 A.V.C. decoupling	1 meg.	39	Tone control	30,000
17	A.V.C. diode load (part)	750,000	40	H.F. stopper	50,000
18	A.V.C. diode load (part)	500,000	41	T.I. grid feed	1 meg.
19	V4 cathode bias	250	42	T.I. grid stopper	500,000
20	V4 anode decoupling	1,000	43	V6 anode decoupling	10,000
21	H.F. stopper	100,000	44	Negative feed-back filter	15,000
22	Demodulator diode load	250,000	45	V7 grid stopper	100,000
23	Volume control	500,000			

CIRCUIT

E. K. COLE, LTD., do not permit publication of the circuit diagram of this receiver. The lay-out diagrams and component tables give the value and purpose of every component, however, and the text provides particularly detailed circuit descriptions. Engineers should have no difficulty in understanding the circuit, which is basically entirely orthodox.

VALVE READINGS

No signal. Volume maximum. M.W. min. cap. 200 volt A.C. mains.

V.	Type.	Electrode.	Volts.	Ma.
1	VP41 ..	Anode ..	230	1.4
		Screen ..	35	.5
2	TX41 ..	Anode ..	225	4.5
		Screen ..	180	4.5
		Osc.anode	145	3
3	T41 ..	Anode ..	205	.9
4	VP41 ..	Anode ..	225	6.5
		Screen ..	230	2.9
5	2D41 ..	Diodes only.	—	—
6	DT41 ..	Anode ..	90	2.3
		Screen ..	230	2.9
7	OP41 ..	Anode ..	275	50
		Screen ..	230	6.8
8	R41 ..	Heaters	325	—

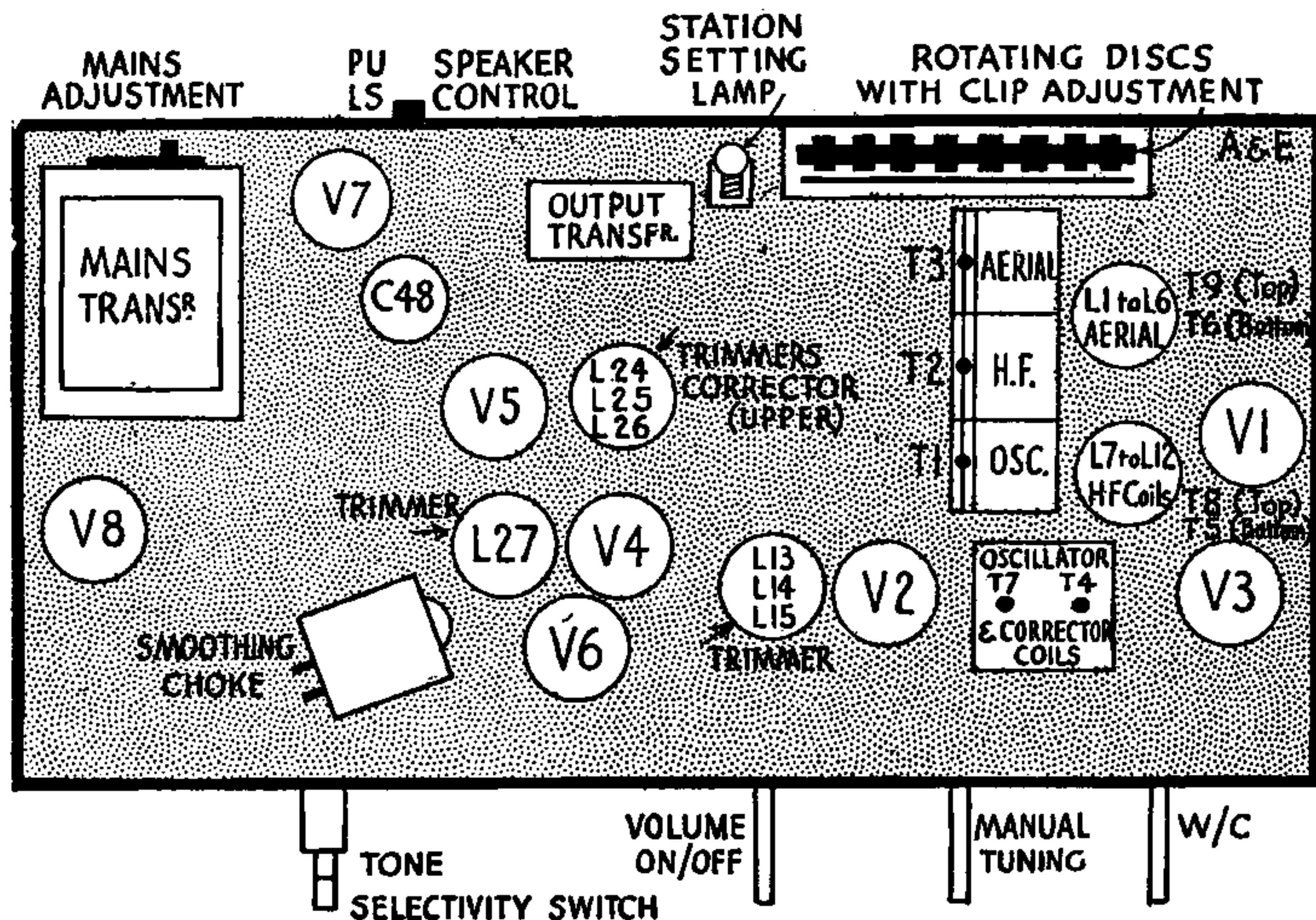

This layout diagram of the top of the Ekco chassis shows the positions of the coils and trimmers and should be referred to in connection with the alignment notes given on page 54

pentode compensator condenser C42 conforms with standard practice, and a variable tone circuit C40 and R49 is also included. Across the secondary of the speaker matching transformer there is a 9-kc. filter (L28, L29 and L30).

Mains equipment consists of a transformer that also provides the power for the tuning motor, a full-wave rectifying valve V8, electrolytic smoothing condensers and a separate smoothing choke. A pair of condensers, C55 and C56, suppress interference from the motor.

A.F.C. Section.—The second I.F. transformer contains a tuned circuit, L26, C29, which feeds the diodes of V5, a double-diode double-cathode valve, which forms the discriminator. A centre tapping of L26 is joined to the anode of V4 through C27, and also to the centre point of two resistors, R29 and R30, which are connected across the two cathodes of V5.

The circuit L26, C29 is tuned to the I.F. At resonance the two diodes of V5 are equally conductive. But when the I.F. is off tune, the signal produced in

L29 inductively and the signal injected via C29 are out of phase. The result is that a larger signal is applied to one diode than to the other. Opposing voltages are developed across R29 and R30, the resultant being fed by R26 and R14 to the grid of the corrector or control valve V3.

The changing grid voltage alters the impedance of V3. This impedance is "reflected" by anode coils into the oscillator circuit of V2. The corrector circuit only operates on automatic tuning.

Auto-Mechanism.—In addition to an orthodox tuning scale, the PB199 has a vertical panel carrying eleven push-buttons. A twelfth button changes to manual control. When a station button is pressed a motor rotates the gang condenser to the required station, the set being silenced until the tune-point is reached.

The key part of the mechanism is a disc mounted on the gang condenser spindle and easily accessible from the back of the set. The disc consists of paxolin and carries two semi-circular plates arranged

Ekco PB199 on Test

MODEL PB199.—Standard model for A.C. mains operation, 200-250 volts, 40-100 cycles. Price 18½ gns.

DESCRIPTION.—Seven-valve, plus rectifier, three-band push-button motor driven superhet table type receiver.

FEATURES.—Full-vision scale calibrated in metres and station names with short wave scale also calibrated in megacycles. Choice of 11 stations automatically tuned by press-buttons. Controls for manual tuning, wave selection, combined volume and on-off, tone and selectivity. Visual tuning indicator. Sockets for gram and L.S., with control of internal speaker.

LOADING.—85 watts. Tuning motor.—40 watts.

Sensitivity and Selectivity

SHORT WAVES (16-50 metres).—Excellent gain and selectivity. Many well-known stations received with small aerial. There is no noticeable drift and tuning is very easy. Scale calibration is accurate.

MEDIUM WAVES (200-560 metres).—Excellent gain. Selectivity depends upon position of selectivity control. In maximum position local stations spread on adjacent channels only. Gain well maintained over band.

LONG WAVES (900-2,000 metres).—Good sensitivity and excellent selectivity. Deutschlandsender received with practically no interference.

Acoustic Output

The tone is very well balanced and there is good radiation at both ends of the scale. Colouration on speech is very slight and balance on orchestral music is excellent.

Motor Tuning

The push-button system was given a very thorough trial on a selected number of stations with strong and also comparatively weak carriers. It functions perfectly in every respect. Provided that the contacts were accurately set, and this operation was found to be exceedingly simple, accurate tuning was obtained.

The AFC action is very strong and the control definitely positive. Our impression of the system is that it will give entirely reliable operation.

with a narrow strip of paxolin between them.

Close to the disc are two semi-circular rails on which are clipped eleven adjustable selector contacts. These make rubbing contact with the flat sides of the metal plates. Each is wired to a push-button switch, the other side of which goes to chassis.

The selectors are insulated from the rails, which act only as supports. Two rails are used, because with only one the size of the selectors would limit the close-

(Continued on page 54)

CONDENSERS

C.	Purpose.	Mfds.	C.	Purpose.	Mfds.
3	V1 A.V.C. decoupling	.04	34	L.F. couplings	.01
5	V1 cathode bias shunt	.1	35	V6 and T.I. cathode bias shunt	.25
6	V1 screen decoupling	.1	36	Negative feed-back condenser	.2
10	V2 A.V.C. decoupling	.04	37	V5 cathodes shunt	.1
11	I.F.T.1 prim. fixed shunt	.00014	38	L.F. coupling	.1
12	V2 anode decoupling	.02	39	V3 grid decoupling	.04
13	Osc. grid	.00005	40	Tone control	.1
17	I.F.T.1 sec. fixed trimmer	.00014	41	V7 cathode bias shunt	.50
18	V3 A.V.C. decoupling	.01	42	Pentode compensator	.0025
19	L.W. osc. fixed padder	.000145	43	Tone control	.2
20	M.W. osc. fixed padder	.00051	44	Tone control	.2
21	S.W. osc. fixed padder	.008	45	V6 anode decoupling	.2
22	V3 anode decoupling	.1	46	H.T. line decoupling	.4
23	V3 grid decoupling	15 cms.	47	H.T. smoothing	12
24	V3 cathode bias shunt	.1	48	H.T. smoothing	8
25	V4 cathode bias shunt	.1	49	V2 cathode bias	.1
26	I.F.T.2 prim. fixed trimmer	.00014	50	T.I. grid decoupling	.1
27	I.F.T.2 prim./sec. coupling	.00014	51	M.W. aerial trimmer	.0002
28	V3 anode decoupling	.02	52	V1 anode bypass	.1
29	Discriminator circuit fixed trimmer	.00014	53	Osc. anode coupling	.001
30	I.F.T.2 sec. fixed trimmer	.00014	54	Tone compensation	.00006
31	H.F. bypass	.0002	55	Motor suppressor	.02
32	A.V.C. diode coupling	15 cms.	56	Motor suppressor	.02
33	H.F. bypass	.0002			

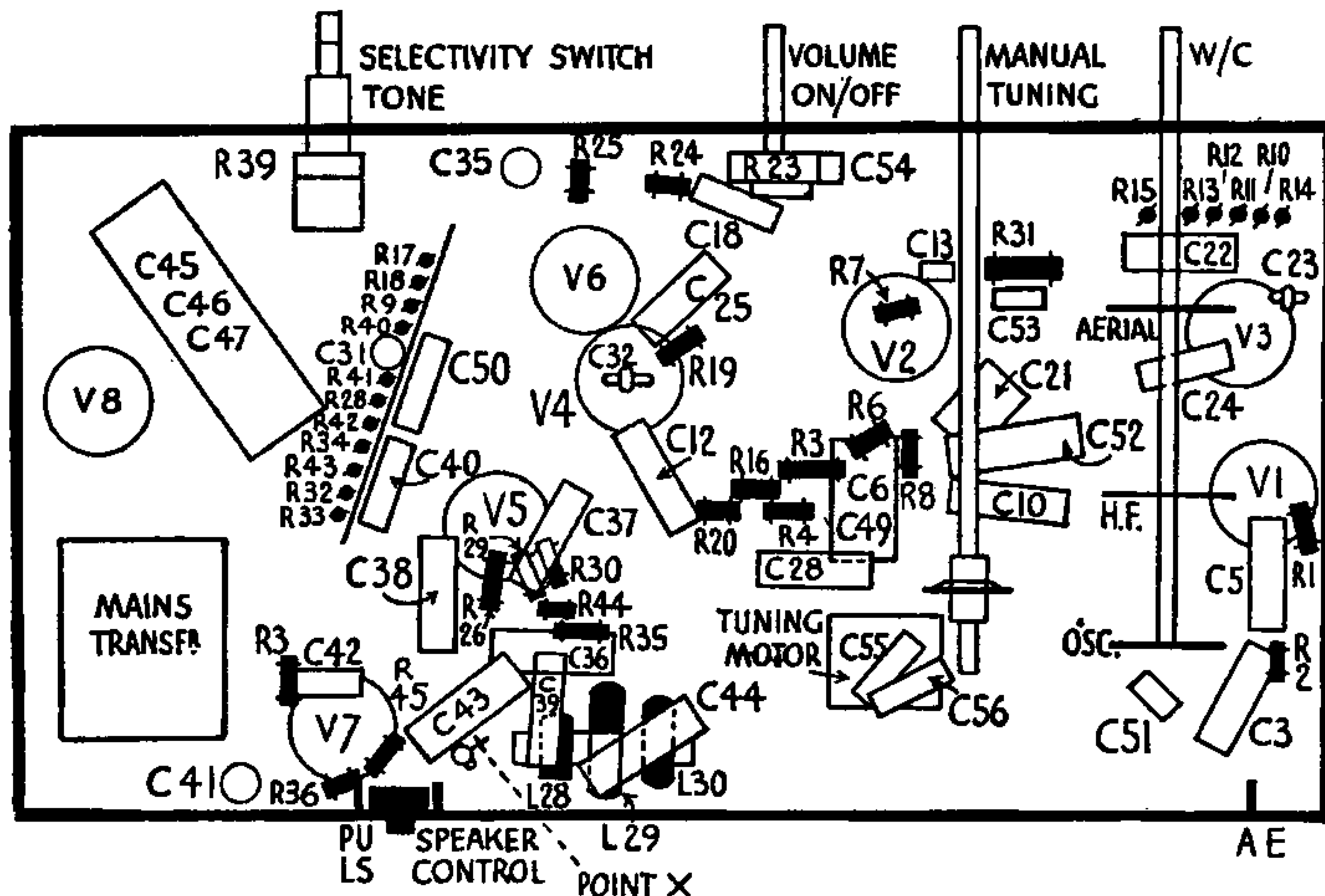

With the discriminator and control valves and rectifier, the PB 199 "five" uses eight valves in all. Construction, is on neat, logical lines. This diagram shows the point "X" (see alignment notes).

EKCO AUTOMATIC PB199

(Continued from previous page.)

ness to which any two stations could be selected.

The two contact plates are wired to two windings on a reversing motor, which can tune the gang either up or down scale as required.

Starting at the chassis the circuit passes through the automatic switch (the twelfth button) to a 22-volt winding on the mains transformer, through either of the motor windings to one of the contact discs, and thence by any one of the push-button switches back to chassis.

When current flows through this circuit the motor turns the gang, and with it the contact disc. The disc turns until the insulating strip between the two plates comes under the selector contact of the button operated, thereby breaking the circuit and stopping the motor.

When a second button is pressed the circuit is completed once more through one of the contact plates, and the motor turns in the required direction.

Associated with the motor are switches which silence the receiver and cut out the automatic frequency control circuit during tuning. The switches are operated by automatic displacement of the motor armature as soon as the driving current flows.

Chassis Removal.—The cabinet has a false bottom secured by six wood screws. Removal of this permits access to the whole of the underside of the chassis to be obtained. If, however, it is required to remove the chassis, proceed as follows:—

Remove the back of the cabinet, the four control knobs, and the four chassis securing bolts from the base. Unclear the leads to the tuning indicator and speaker from the front (inside) of the cabinet. Then remove the four bolts securing the station name plate. Removal of this panel reveals two more bolts securing the auto-switch mechanism, and these should be removed, when the chassis can be withdrawn.

The speaker, secured by four nuts, may be removed if desired and the chassis operated externally. If the chassis is operated externally, care should be taken to prevent the press-button mechanism contacts touching the chassis.

Special Notes.—An insulating panel at the rear of the chassis carries pairs of sockets for a pick-up and an extension speaker. The extension speaker should have an impedance of 3 to 4 ohms. A small knob near the L.S. sockets provides control of the internal speaker.

There are two pilot lights mounted in screw-in holders and clamped to the top of the wavelength scale. These are rated at 6.2 volts .3 amp., and have M.E.S. bases. A similar lamp at the rear of the chassis deck is for calibrating the push-buttons.

R27 and R37 are located on the tuning indicator valve holder near the top of the wavelength dial assembly. C19 and C20 are in the oscillator can, C11 and C17 with L13 to L15, C26, C27 and C29 with L24 to L26 and C30, C31, C33, R21 and R22 with L27.

The mains input lead, at the chassis end, is terminated in bakelite cased recessed sockets that fit plugs under the chassis at the rear, the bakelite plug

WINDINGS (D.C. Resistances)

Winding.	Ohms.	Range	Where measured.	Winding	Ohms.	Range	Where measured.
L1 ..	.6	S.W.	Aerial socket and chassis.	L16 ..	14.4	M.W.	Anode V3 and R15 + C22.
L2 ..	30.7	M.W.	Aerial socket and chassis.	L17 ..	55	L.W.	Anode V3 and R15 + C22.
L3 ..	153.9	L.W.	Aerial socket and chassis.	L18 ..	Below .1	S.W.	C53 and C21.
L4 ..	.3	S.W.	Top grid V1 and C3.	L21 ..	.25	S.W.	C13 and chassis.
L5 ..	3	M.W.	Top grid B1 and C3.	L22 ..	.75	M.W.	C13 and chassis.
L6 ..	22.3	L.W.	Top grid V1 and C3.	L23 ..	1.4	L.W.	C13 and chassis.
L7 ..	.4	S.W.	Anode V1 and C52.	L24 ..	4.7	—	Anode V4 and C28 + R20.
L8 ..	4	M.W.	Anode B1 and C52.	L26 ..	.9	—	Across diodes V5.
L9 ..	*7.5	L.W.	Anode V1 and C52.	L28 ..	3.4	—	Across tags.
L10 ..	.2	S.W.	Top grid V2 and C10.	L29 ..	2.7	—	Across tags.
L11 ..	2	M.W.	Top grid V2 and C10.	L30 ..	4.3	—	Across tags.
L12 ..	21	L.W.	Top grid V2 and C10.	Field ..	432	—	Across tags.
L13 ..	4.5	Any	Anode V2 and R4.	O.T. prim. ..	170	—	Anode of V7 + C47.
L14 and L15	5	Any	Top grid V4 and R16.	Tertiary ..	19	—	R35 and chassis.
				M.T. prim. .	21	—	Across mains pins.
				Total H.T. sec.	311	—	Anodes V8.

partly passing through a slot in the chassis.

The automatic push-button system does not operate on the short waveband or when the wave selection switch is in the gram. position.

Circuit Alignment Notes

I.F. Circuits.—With this receiver it is important that the I.F. circuits be lined up first and that the complete I.F. procedure be carried out.

A signal of 480 kc. should be injected from a service oscillator through a .02-mfd. condenser to the grid of the TX41. The set should be tuned to the top of the medium waveband. Connect an output meter to the output transformer.

With a non-metallic screwdriver adjust the iron cores of the following coils (see lay-out diagram of upper side of chassis) for maximum deflection: I.F.T.1 (can containing Ls 13, 14 and 15), I.F.T.2 (can containing Ls 24, 25 and 26) and the demodulator coil (can containing L27).

Note, however, this exception: the I.F.T.2 secondary trimmer (at top of L24-26 can) must be adjusted as follows: Connect a high-resistance voltmeter (20,000 ohms per volt) between the insulated screw "X"—see chassis lay-out diagram—and chassis. Adjust core for zero voltage. (The point "X" is electrically between one cathode of V5 and the 500,000-ohm resistor R30.)

In the case of the primary of I.F.T.1 (bottom trimmer on L13-15 can), the core should be on the trimming side of the centre—i.e., towards the front of the chassis. In the case of the primary of I.F.T.2 (bottom trimmer L24-26 can) the core should be on the side remote from the trimming end—i.e., also towards the front of the chassis.

Reduce the input as the circuits come into line to keep below the point at which the A.V.C. operates.

Signal Circuits.—Connect the service oscillator to the aerial and earth sockets

via a dummy aerial, only feeding sufficient input to obtain reliable peaks in the output meter.

The wavelength pointer should cover the black line at the end of the M.W. scale when at maximum. The control and discriminator valves must be in position.

Short Waves.—Tune set and oscillator to 18 mc. and adjust T1 for maximum.

Tune set and oscillator to 17 mc. and adjust T2 and T3 for maximum.

Medium Waves.—Tune set and oscillator to 200 metres (1,500 kc.), screw T4 right up and then unscrew until the first peak is heard.

Tune set and oscillator to 250 metres (1,200 kc.) and adjust T5 and then T6 for maximum.

Tune to 500 metres and adjust top core of oscillator can for correct calibration. Keep core on far side of centre.

Repeat whole procedure for final adjustment.

Long Waves.—Tune set and oscillator to 1,300 metres and adjust T7 for correct calibration and T8 and T9 for maximum output.

Tune to 1,700 metres and adjust L.W. oscillator core (bottom core, oscillator coil can) for correct calibration. Keep core on far side of centre.

Repeat procedure for final adjustment.

AUTOMATIC TUNING—12

(Continued from page 1)

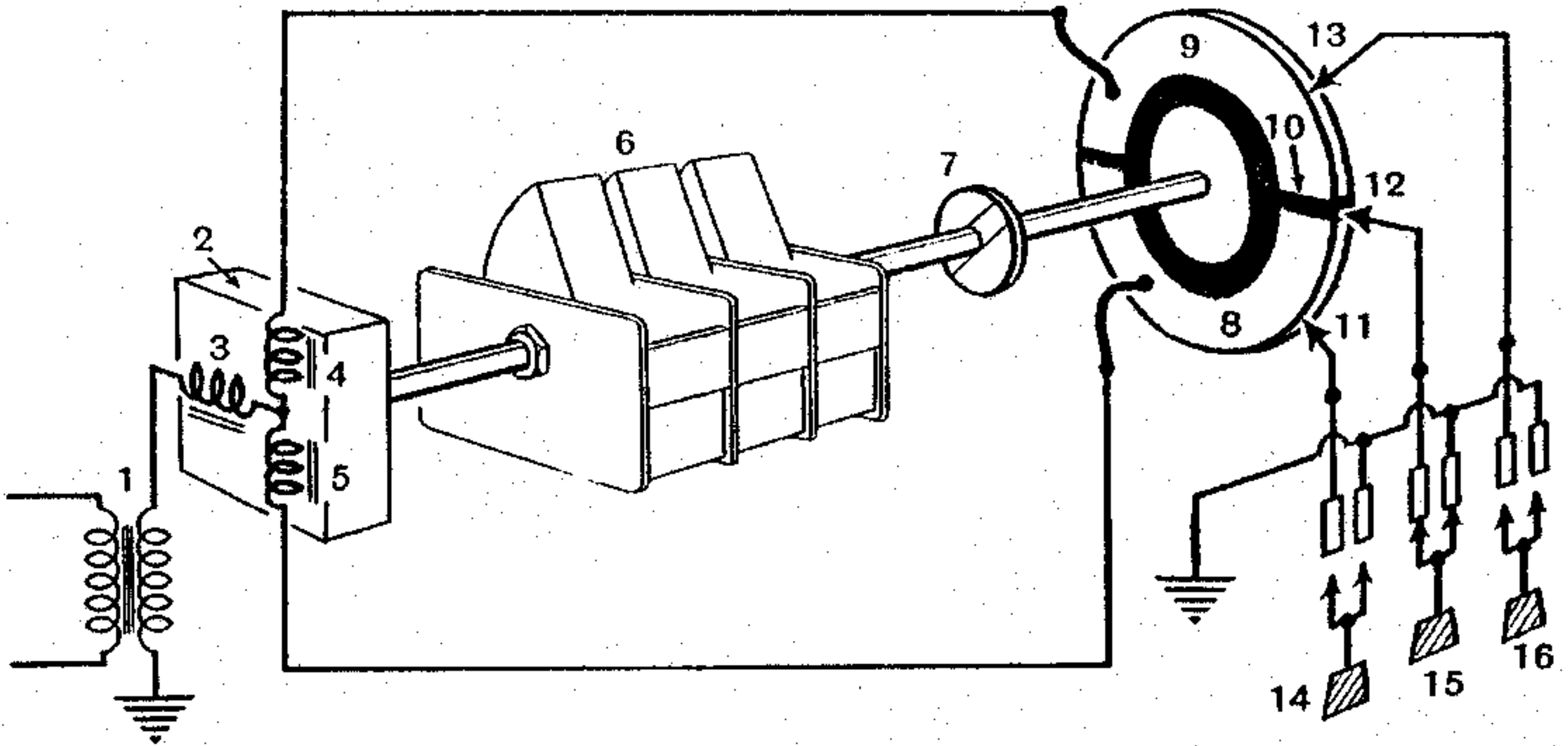

Fig. 2.—Schematic diagram of a single disc "direct-homing" system.

8 to motor windings 5 and 3, through the secondary of 1, and so to earth. The motor then runs, driving the gang and selector disc clockwise until 10 comes under 11, and so breaks the circuit. In Fig 2, contact 12 is in this position, and switch 15 is closed.

If switch 16 is closed (15 opening), the circuit is now via contact 13, segment 9 and motor windings 4 and 3. Since winding 4 instead of 5 is in circuit, the motor now drives the gang anti-clockwise until strip 10 comes under contact 13.

So the system is "direct-homing," and only one selector disc is used. The mechanical layout used by Ekco in the PB199 is shown in Fig 3. Here 1, 2 and 3 are the tuning scale, pointer and gang condenser. The contact clips (5) are mounted on, but insulated from, two semi-circular carrier rails (4), two being used to allow stations on adjacent channels to be selected. 6 represents the leads from each contact clip to the press buttons on the front of the cabinet. 7 (upper arrow) is the insulated strip which breaks the contact of any clip under which it passes with the heavily silvered selector plates

(lower arrow). 8 is the motor, and when it is excited its spindle 9 is drawn into a position which engages the clutch, and also closes switches for noise suppression and for cutting out the AFC circuits. When the motor stops, the clutch is released and the switches open.

10 is a pilot lamp to help in selecting stations. The procedure is to press the manual tuning button and also the button which is to be set to the required station. Now tune in the station manually, and adjust the position of the clip corresponding to the depressed selector button until it rests on the insulated strip in the selector disc. This is assisted by the lamp, which glows as long as the clip in question is on the metal selector plate, but goes out when the clip is on the insulation.

The Ekco clips can be removed instantaneously from their rails, interchanged, or replaced in any order. In some of the American sets it was more difficult to interchange the contacts, which were fitted in semi-circular grooves in a flat plate, and were held in position by screws and nuts.

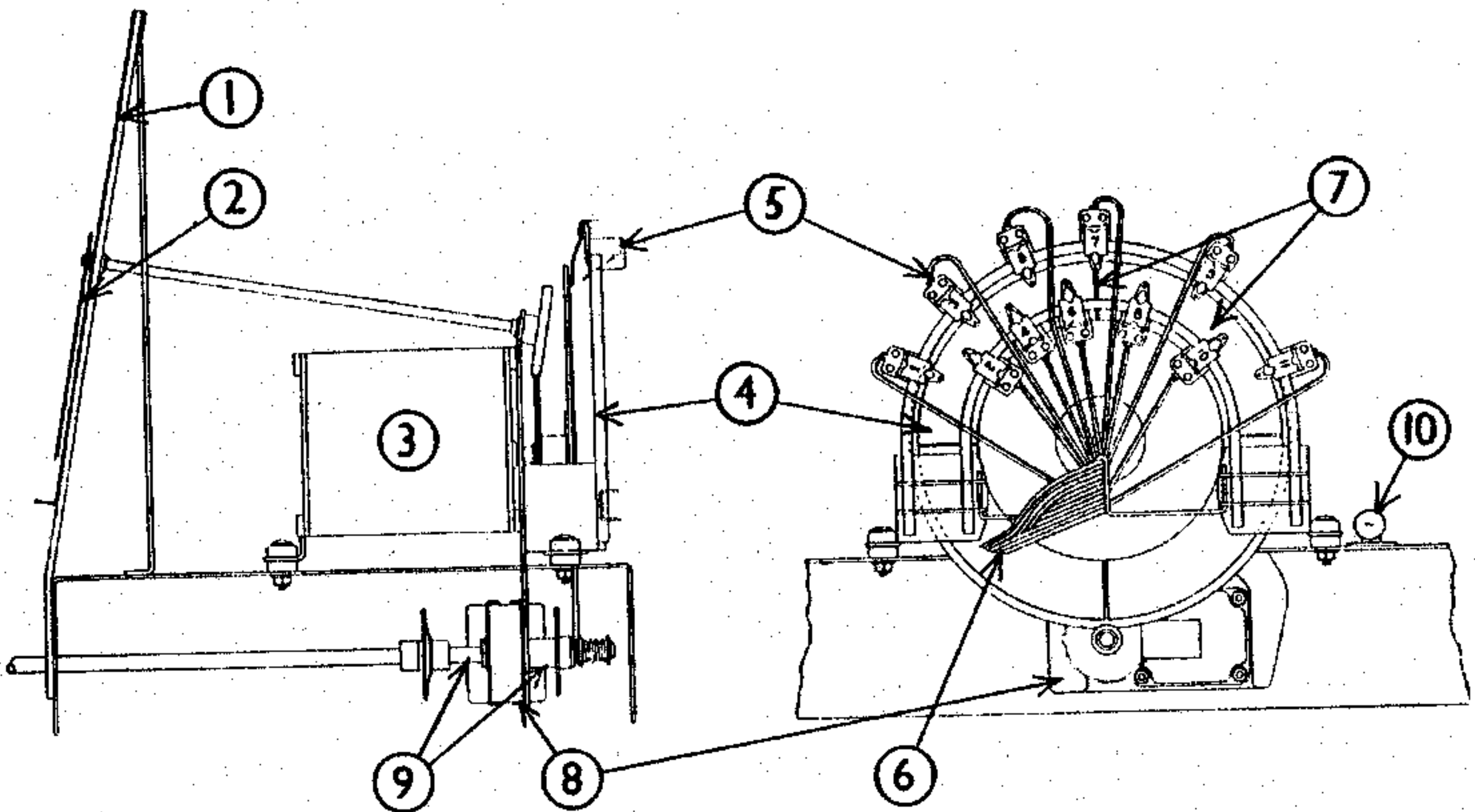

Fig. 3.—Mechanical layout of the Ekco PB199 receiver.