

Ned. Ver. v. Historie v/d Radio

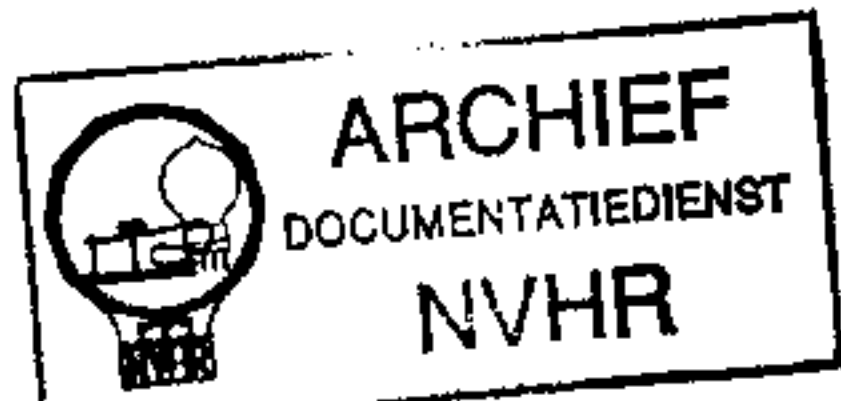

# EKCO BV67 (VIBRATOR MODEL) AND B67

REVISED ISSUE OF  
SERVICE SHEET No. 198

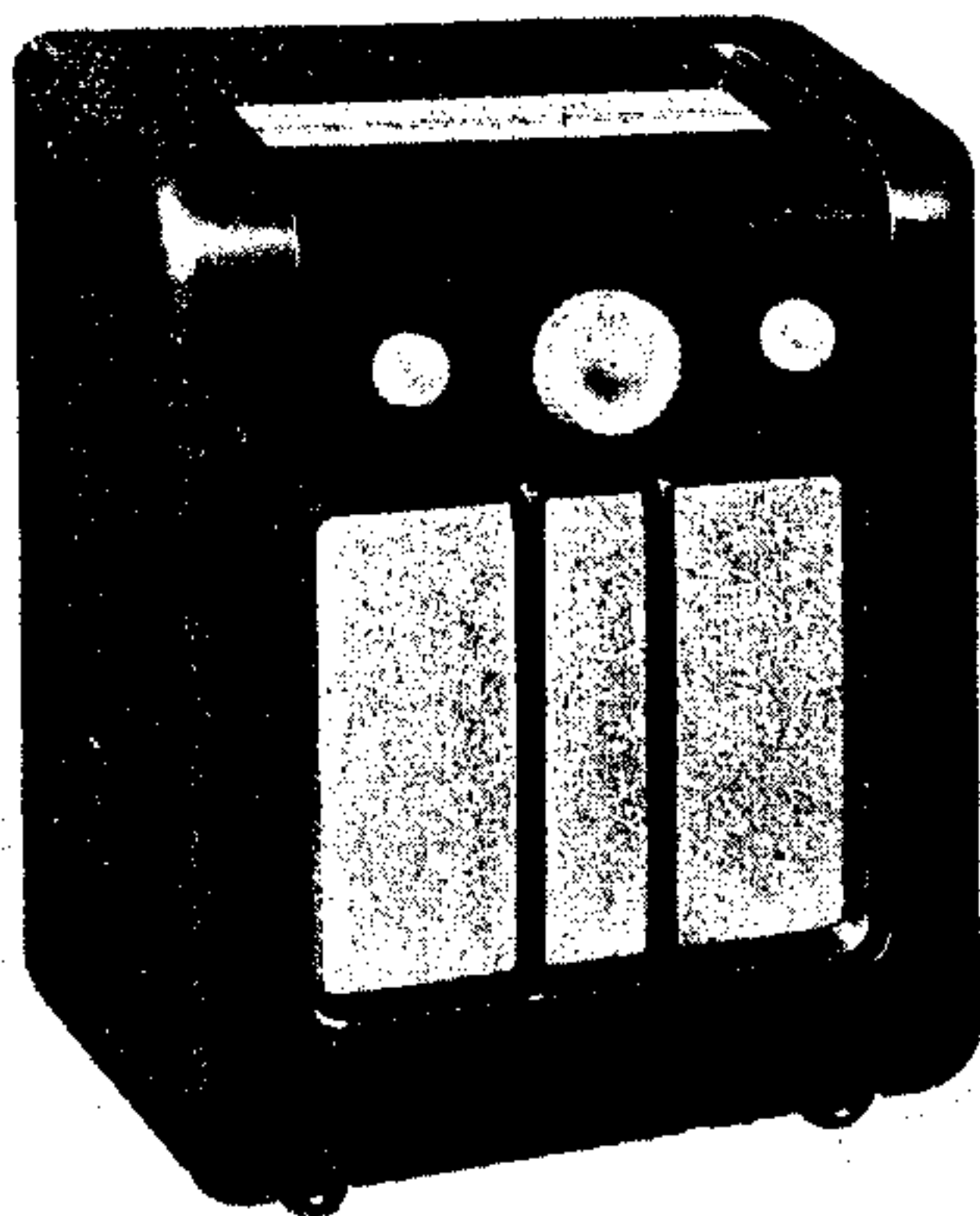

The appearance of the EKCO BV67 in the black and ivory finish. The alternative finish is walnut. The appearance of the B67 is similar.

**D**ESIGNED to operate without an HT battery, the Eko BV67 is a 5-valve, 2-band superhet. HT supply is derived from a vibratory converter unit operated from a 4 V accumulator. 2 V valves are used, connected in series-parallel across the 4 V supply.

A two-valve frequency changer circuit is employed, and the double diode detector is indirectly heated. Provision is made for connecting a gramophone pick-up and an external speaker. The set is housed in a moulded cabinet, available in walnut or black and ivory finish.

The Ekco B67 employs basically a chassis like that in the BV67, but it is designed for use with an HT battery and a 2 V accumulator. The differences between the two models are described under "General Notes." Its cabinet is similar to that of the BV67, and is available in both finishes.

Release date, both models: July, 1936.

Original prices: BV67, walnut finish, £12 12s.; black and ivory finish, £12 19s. 6d. B67, walnut finish, £9 9s.; black and ivory finish, £9 16s. 6d.

## CIRCUIT DESCRIPTION

Aerial input via MW coupling condenser C1 and LW coupling coil L1 to inductively coupled band-pass filter. Primaries L2 (MW) and L3 (LW) tuned by C19. Secondary L4, L5 (MW and LW) tuned by C21. Image rejection by pre-set condenser C18.

First valve (V1, Mullard metallised

VP2) is a variable-mu RF pentode operating as first detector, with suppressor grid injection from separate triode oscillator (V2, Mullard metallised PM1HL). Oscillator anode coils L6, L7 tuned by C24; parallel trimming by C23; tracking by shaped condenser vanes, and C7, C25 (LW); oscillator grid coils L8, L9.

Third valve, a variable-mu RF pentode (V3, Mullard metallised VP2) operates as intermediate frequency amplifier with tuned-primary tuned-secondary transformer couplings C26, L10, L11, C27 and C28, L12, L13, C29.

Intermediate frequency 126.5 kc/s.

Diode second detector is part of separate double diode valve (V4, Mullard metallised 2D2) with indirectly heated cathode. Audio-frequency component in rectified output is developed across load resistor R10 and passed via coupling condenser C13 and manual volume control R11 to CG of pentode output valve (V5, Mullard PM22D). IF filtering by L14, C11 and C12.

Variable tone control in V5 anode circuit by RC filter R12, C16. Fixed tone correction by C15. Provision for connection of external low impedance speaker across secondary of T1. Small screw switch S9 permits internal speaker speech coil circuit to be broken. Provision for connection of gramophone pick-up in control grid circuit of V5.

Second diode of V4, fed from V3 anode via C10, provides DC potentials which are developed across load resistors R7, R8,

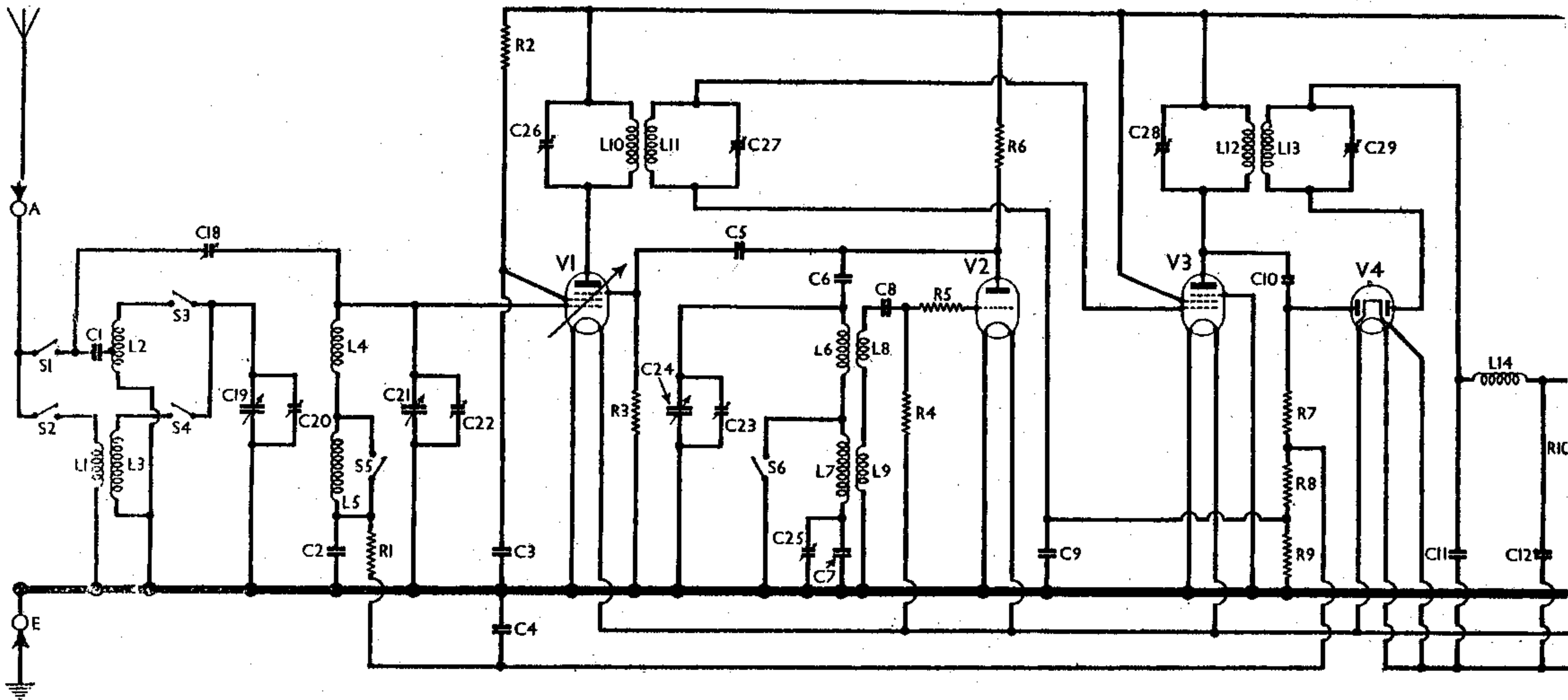

Plan view of the receiver chassis. A plate has been removed from beneath the scale pointer, and the cover has been removed from the L1-L5 coil assembly, showing the position of the waveband switch unit. A diagram showing the switch unit in detail, as viewed from the bottom of this illustration, will be found in col. 4 overleaf.

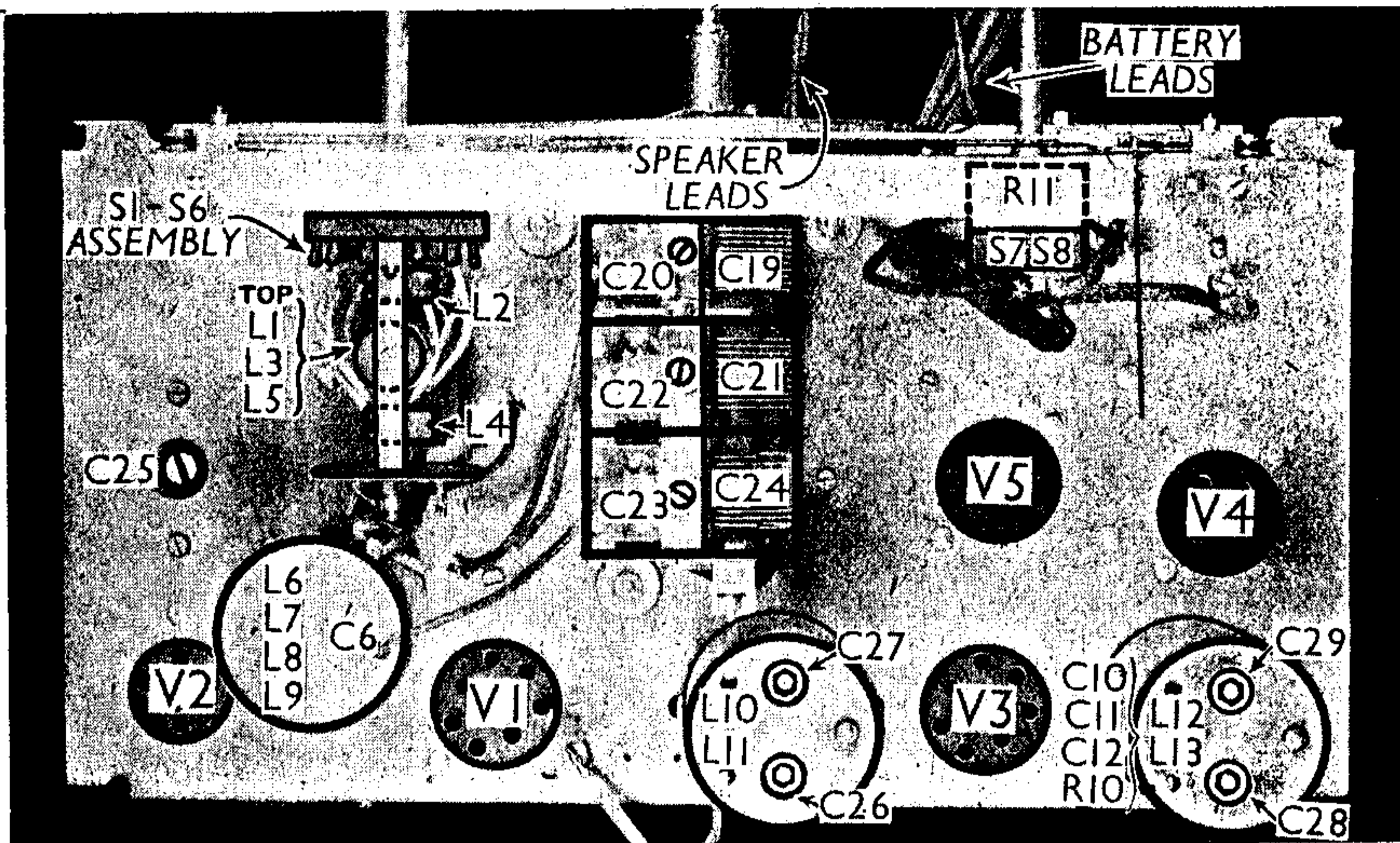

R9, and fed back through decoupling circuits as GB to first detector and IF valves, giving automatic volume control.

Delay voltage and V5 GB potential are obtained from drop across the filament circuits, which altogether total 4 V. V1, V2 and V3 are connected in parallel; and so are V4, V5, with their ballast resistor R13; but the two groups are connected in series across the 4 V accumulator, V4, V5 being at the positive end.

Filtering in HT positive circuit by L16, C14, and in LT positive circuit by L17, C17.

**Converter Chassis.**—LT input to vibrator unit causes two pairs of primary contacts to open and close alternately,

feeding LT pulses in rapid succession to alternate halves of the centre-tapped primary of the HT output transformer T2. HT pulses produced in secondary of T2 are rectified by two pairs of secondary contacts in vibrator unit, providing full wave rectification. Smoothing by R14, C34 and C35. Filter and by-pass network C31, C32 and C33, and L18, C36 on LT side; RF filtering on HT side by C30, C37. Fuse F1 in LT positive lead protects the input circuit.

### VALVE ANALYSIS

Valve voltages and currents in the table (next column) are those measured in our receiver when it was operating from fully

charged accumulators. The receiver was tuned to the lowest wavelength on the medium band and the volume control was at maximum, but there was no signal input.

Voltages were measured on the 1,200 V scale of an Avometer, chassis being negative.

Valve	Anode Voltage (V)	Anode Current (mA)	Screen Voltage (V)	Screen Current (mA)
V1 VP2	135	1.0	105	0.3
V2 PM1HL	35	1.0	—	—
V3 VP2	135	1.0	135	0.4
V4 2D2	—	—	—	—
V5 PM22D	130	7.8	135	1.3

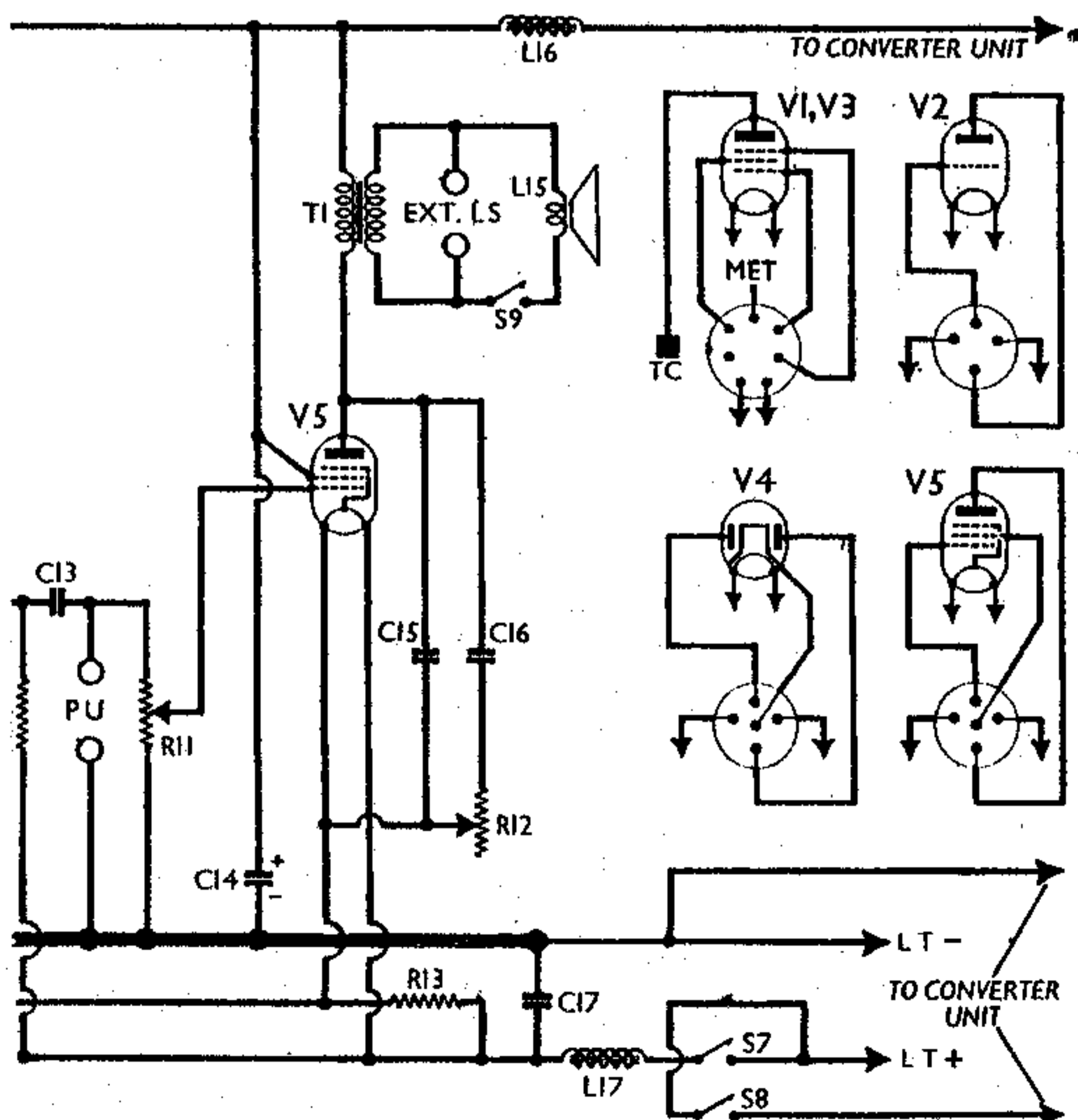

*Left:* Circuit diagram of the EKCO BV67 superhet. V2 is a separate oscillator valve operating in conjunction with V1 as frequency changer. Note that the LT supply is 4V, and that the 2V valve filaments are arranged in two groups, the groups being connected in series. R13 is a ballast resistor in the V4, V5 group. The set will operate as it is with normal batteries, provided that a 4V accumulator is used.

*Right:* Circuit diagram of the vibratory converter unit, which obtains its driving energy from the 4V accumulator and supplies H.T. current to the receiver. Three leads provide the connections between the receiver and the unit.

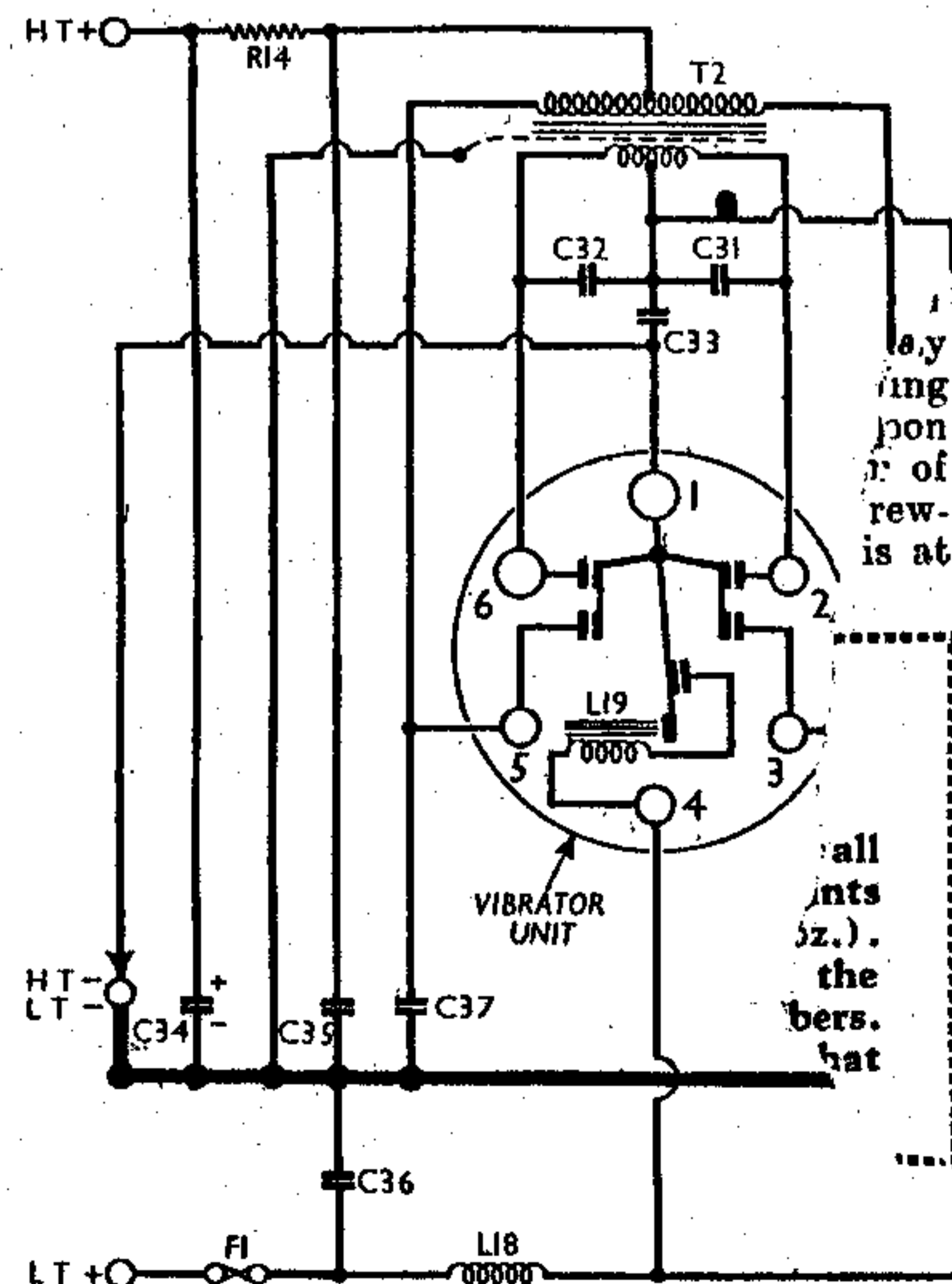

COMPONENTS AND VALUES

RESISTORS		Values (ohms)
R1	V1 CG decoupling ...	250,000
R2	V1 SG HT feed ...	40,000
R3	V1 injector resistor ...	500,000
R4	V2 CG resistor ...	30,000
R5	V2 CG stabiliser ...	2,000
R6	V2 anode HT feed ...	100,000
R7	V4 AVC diode load resistors ...	250,000
R8		500,000
R9		500,000
R10	V4 signal diode load ...	500,000
R11	Manual volume control ...	1,000,000
R12	Variable tone control ...	250,000
R13	V4, V5 filament shunt ...	19.5
R14	HT smoothing resistor ...	500

CONDENSERS		Values (µF)
C1	Aerial MW coupling ...	0.0008
C2	V1 CG decoupling ...	0.1
C3	V1 SG decoupling ...	0.1
C4	V1 AVC line decoupling ...	0.02
C5	Osc. coupling condensers	0.0005
C6		0.0005
C7		0.0007
C8	Osc. LW tracker ...	0.0005
C9	V2 CG condenser ...	0.1
C10	V3 CG decoupling ...	0.00001
C11	V4 AVC diode feed ...	0.0003
C12	IF by-pass condensers	0.001
C13		0.01
C14*	AF coupling to V5 ...	20.0
C15	HT smoothing condenser	0.001
C16	Fixed tone corrector ...	0.01
C17	Part variable tone control	0.25
C18	LT circuit by-pass ...	—
C19	Image rejector ...	—
C20	Band-pass pri. tuning ...	—
C21	Band-pass pri. trimmer	—
C22	Band-pass sec. tuning ...	—
C23	Band-pass sec. trimmer	—
C24	Osc. circuit trimmer ...	—
C25	Osc. circuit tuning ...	—
C26	Osc. LW tracker ...	—
C27	1st IF trans. pri. tuning	—
C28	1st IF trans. sec. tuning	—
C29	2nd IF trans. pri. tuning	—
C30	2nd IF trans. sec. tuning	0.01
C31	Converter unit ...	0.1
C32		0.1
C33	Interference suppressors	0.1
C34*		8.0
C35	HT smoothing condensers	0.25
C36		0.5
C37	Converter unit interference suppressors	0.01

OTHER COMPONENTS		Approx. Values (ohms)
L1	Aerial LW coupling ...	30.0
L2	Band-pass primary coils	3.5
L3		30.0
L4	Band-pass secondary coils	3.5
L5		30.0
L6	Oscillator anode tuning coils ...	5.0
L7	...	10.0
L8	Oscillator grid coils, total	5.0
L9		...
L10	1st IF trans. { Pri. ...	75.0
L11		Sec. ...
L12	2nd IF trans. { Pri. ...	75.0
L13		Sec. ...
L14	IF filter choke ...	260.0
L15	Speaker peech coil ...	2.7
L16	HT smoothing choke ...	310.0
L17	LT filter choke ...	0.35
L18	Converter unit RF choke ...	0.1
L19	Vibrator energising coil ...	7.0
T1	Output trans. { Pri. ...	700.0
T2	Sec. ...	0.15
	Converter trans. { Pri. (total) ...	0.15
	Sec. (total) ...	950.0
S1-S6	Waveband switches ...	—
S7	LT filament switch ...	—
S8	LT converter switch ...	—
S9	Internal speaker switch ...	—
F1	Converter LT fuse (10A) ...	—

\* Electrolytic. † Variable. ‡ Pre-set.

DISMANTLING THE SET

**Removing Chassis.**—Remove the three control knobs (recessed grub screws) from the front of the cabinet, and the tone control (recessed grub screw inside cabinet) from the side;

remove two screws (with washers and lock-washers) holding the back of the chassis to the cabinet; remove two screws (with lock-washers) holding the front of the chassis to the cabinet; unsolder the leads from the speaker connecting panel; remove the two screws (with metal and rubber washers) holding the vibrator assembly to the base of the cabinet, and one screw (with washer) holding it to the rear of the cabinet.

The receiver chassis and vibrator assembly may now be withdrawn together, but to obtain access to the compartment beneath the receiver chassis, a fibre cover must be removed (four screws with lock-washers).

When replacing, do not omit to fit the rubber washers beneath vibrator assembly.

The green spot on the waveband switch knob should be uppermost with the switch in the MW position.

If the vibrator assembly has been separated from the receiver chassis, connect the HT positive lead from the receiver to the tag on the extreme left of the fuse terminals, when viewed from the direction of the vibrator socket, and the LT positive lead (4 V) to the tag on the extreme right (this tag is connected to the right-hand fuse terminal).

A third lead, metal braided and covered with black systoflex, with the LT negative lead attached to it, goes on to a bolt fitted directly on to the metal chassis of the vibrator assembly, together with a metal braided lead from pin 1 of the vibrator unit socket.

**Removing Speaker.**—Remove the nuts (with washers and lock-washers) from the four bolts holding the speaker to the sub-baffle.

When replacing, the connecting panel should be on the right.

GENERAL NOTES

**Switches.**—S1-S6 are the waveband switches, in a single rotary unit inside the band-pass coil unit. The cover of this unit has been removed in our plan chassis view, and the switch unit is indicated. A detailed diagram appears in col. 4, drawn as seen when viewed from the rear of the chassis.

The table below gives the switch positions for the two control settings, LW (anti-clockwise) and MW (clockwise). A dash indicates open, and C, closed.

Switch	LW	MW
S1	—	○
S2	○	—
S3	—	○
S4	○	—
S5	—	○
S6	—	○

S7 is the LT filament switch, and S8 the converter LT switch, in a single QMB unit ganged with the volume control R11.

S9 is the internal speaker switch, of the screw type, operated by a knob at the rear of the chassis.

**Coils.**—L1-L5 are inside the horizontally mounted unit, containing also the switch unit. Its cover has been removed in our plan chassis view. This unit also contains C1, shown in the under-chassis

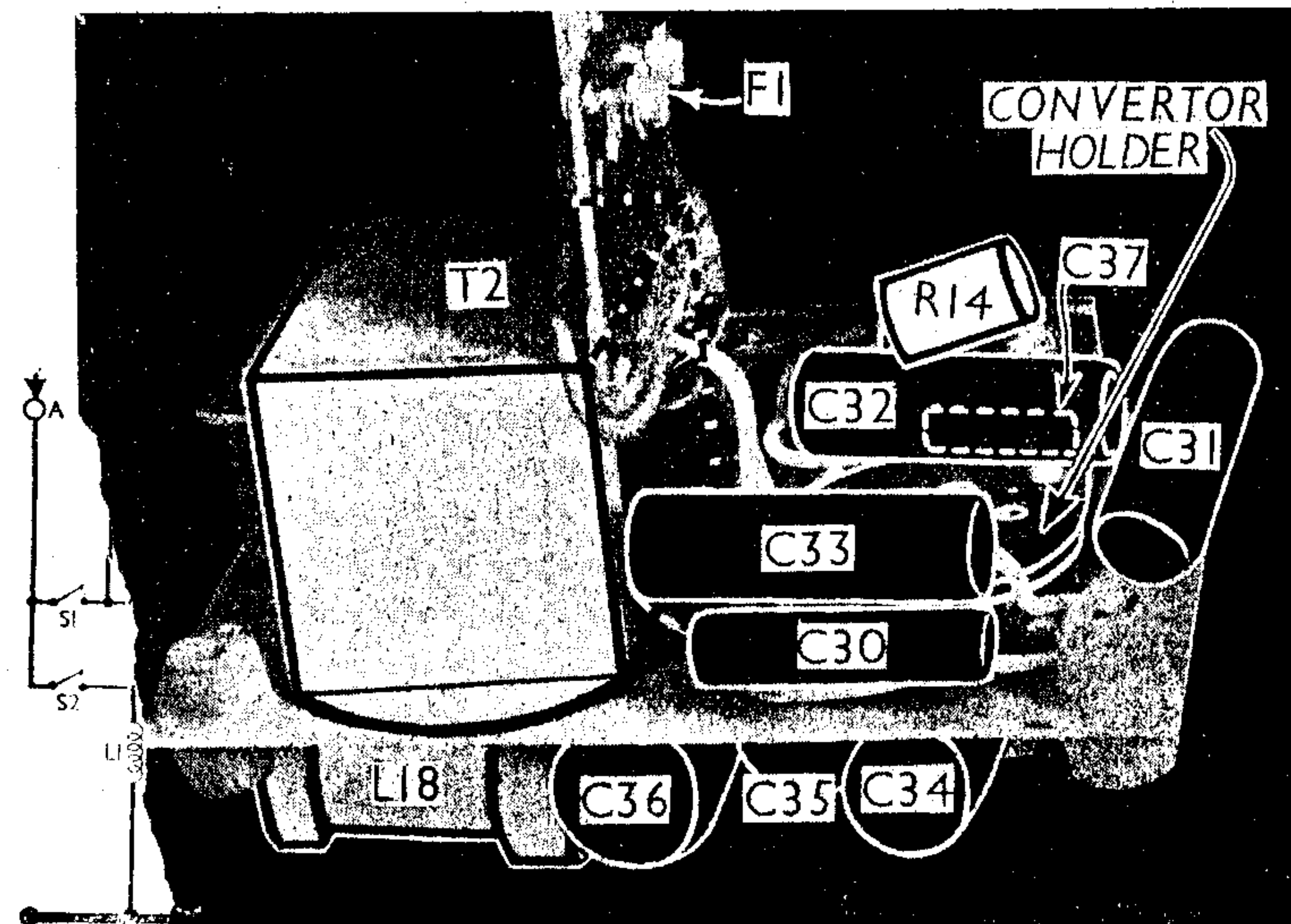

Three-quarter plan view of the converter unit assembly, showing the components above and below the chassis deck. The H.T. + lead and L.T. + lead from the receiver go to two tags, one either side of the fuse F1. The vibrator unit plugs into the holder indicated.

Under-chassis view of the BV67 receiver. C<sub>9</sub> is beneath C<sub>4</sub> in this view. The two smoothing chokes L<sub>16</sub>, L<sub>17</sub> are omitted in the B67. C<sub>1</sub> is actually mounted beneath the L<sub>1</sub>-L<sub>5</sub> coil assembly on the chassis deck, but is seen here through a hole in the pressing.

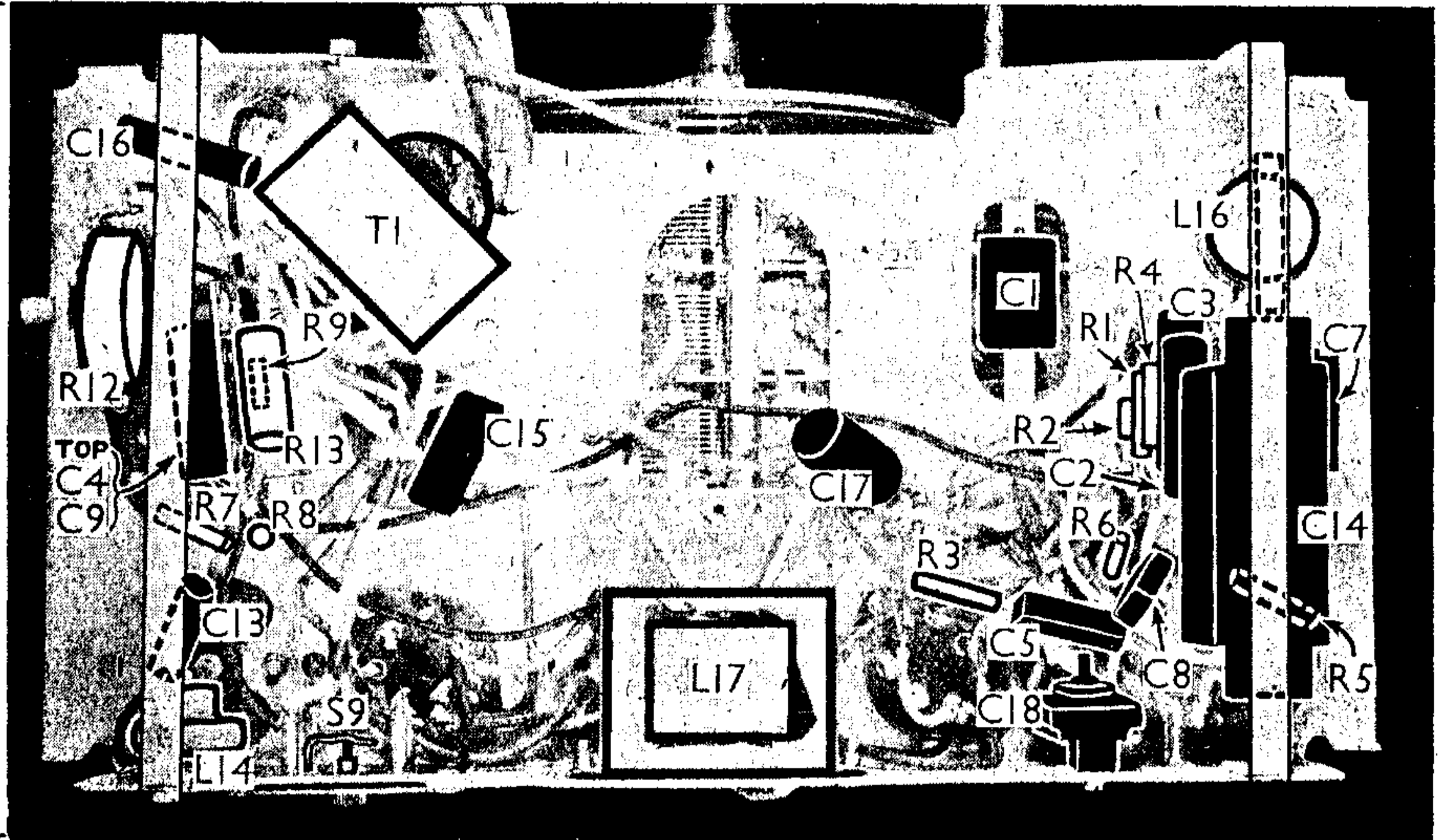

view. L<sub>6</sub>-L<sub>9</sub> are in a screened unit on the chassis deck, containing also C<sub>6</sub>. The IF transformers L<sub>10</sub>, L<sub>11</sub> and L<sub>12</sub>, L<sub>13</sub> are in two further screened units, with their trimmers. The second unit also contains C<sub>10</sub>, C<sub>11</sub>, C<sub>12</sub> and R<sub>10</sub>. The condensers can be identified by their values.

The chokes L<sub>14</sub>, L<sub>16</sub> and L<sub>17</sub> are beneath the chassis. L<sub>18</sub> is in the converter unit.

**External Speaker.**—Two sockets are provided at the rear of the chassis for a low impedance (about 3 Ω) external speaker. S<sub>9</sub> can be used to cut out the internal speaker.

**Converter Unit.**—This uses an Oak 4 V vibrator in a tubular metal case, fitted with an American 6-pin base. Looking at the ends of the pins, with the thick pair at the bottom, and numbering in a clock-

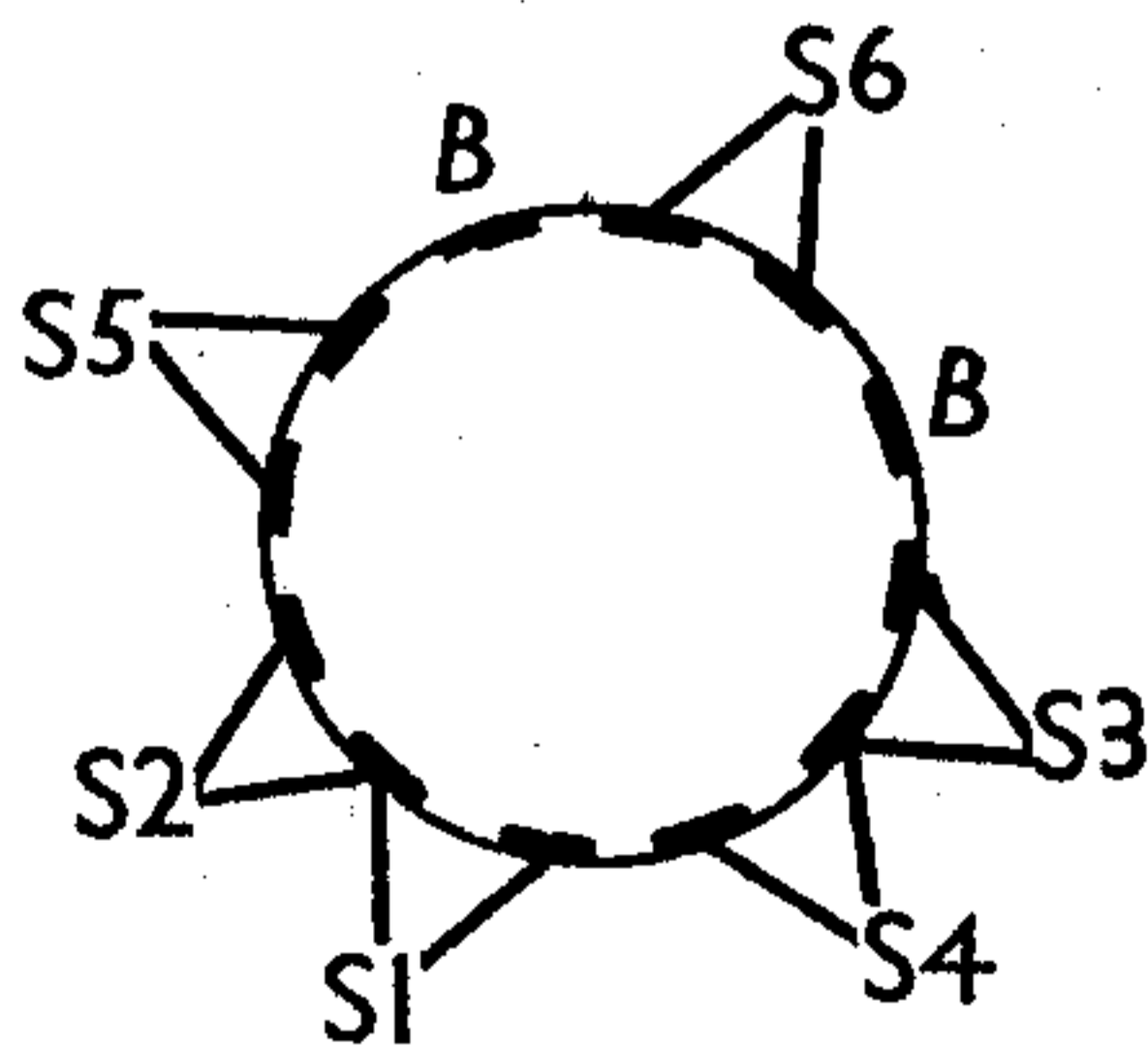

Diagram of the waveband switch unit, as seen when viewed from the rear of the upper side of the chassis. Normally it is covered by a coil screen.

wise direction from the left-hand thick pin, the energising winding L<sub>19</sub> of the vibrator is between pins 1 and 4 (7 Ω approx.), the LT contacts go to pins 2 and 6, and the HT contacts to pins 3 and 5.

The total LT consumption should be 1.4 A, that of the converter alone being 0.9 A, while the valve filaments alone take 0.5 A. The HT voltage from the converter should be about 144 V on load (15.5 mA), or 170 V with the HT positive lead to the set disconnected.

**Batteries and Connections.**—Two Exide CZH4 2 V cells in series are used, one each side of the converter unit. Of the leads from the receiver the light blue lead with black rubber end goes to negative of left-hand cell; dark blue and black rubber leads with red rubber end to positive of left-hand cell; light blue lead with red rubber end to positive of right-hand cell. A black systoflex lead from converter to negative of right-hand cell.

**B67 Divergencies.**—The ordinary battery receiver uses ordinary LT and HT battery supplies, a 2 V Exide CZH3 cell and a 144 V Drydex H1083 HT battery. L<sub>16</sub>, L<sub>17</sub> and C<sub>17</sub> are omitted; all filaments are in parallel for the 2 V supply, and R<sub>13</sub> is omitted; S<sub>7</sub> is in the LT negative lead and S<sub>8</sub> in the HT negative lead; a 300 Ω bias resistance is between the HT negative and LT negative line, the bottom end of R<sub>11</sub> being returned to the HT negative side of this resistance. There are other small differences, but basically the two chassis are the same.

The BV67 can be used as an ordinary battery receiver, with a normal HT battery, but unless modifications are made to the heater circuits and grid return leads, a 4 V accumulator must still be used.

### CIRCUIT ALIGNMENT

**IF Stages.**—Connect output meter (0.5 V AC) to external speaker sockets. Connect signal generator to top cap of V<sub>1</sub>, via a 0.02 μF condenser, leaving existing anode lead connected. The other output lead of generator goes to the E socket. Feed in a 126.5 kc/s (2,372 m) signal, and adjust C<sub>26</sub>, C<sub>28</sub>, C<sub>27</sub>, C<sub>29</sub> in

that order for maximum output. Re-check.

**RF and Oscillator Stages.**—With the gang at maximum, the pointer should cover the 560 m calibration mark on the scale. Connect the signal generator, via a suitable dummy aerial, to A and E sockets.

**MW.**—Switch set to MW, tune to 200 m on scale, feed in a 200 m (1,500 kc/s) signal, and adjust C<sub>23</sub> for maximum output, selecting the peak involving the lesser trimmer capacity.

Feed in a 250 m (1,200 kc/s) signal, tune it in, and adjust C<sub>22</sub> and C<sub>20</sub> for maximum output.

**LW.**—Switch set to LW, tune to 1,700 m on scale, feed in a 1,700 m (176.5 kc/s) signal, and adjust C<sub>25</sub> (through a hole in chassis deck) for maximum output, while rocking gang slightly for optimum results.

**Image Rejector.**—This should be adjusted on the most powerful MW station, usually the local Regional. Look up the frequency of this station and subtract 253 kc/s (twice the intermediate frequency). The result is the frequency on which second channel interference may be caused. Tune to the station operating on or near this frequency, and, upon detecting the image, adjust C<sub>18</sub> (rear of chassis) by means of a non-metallic screwdriver until the interference whistle is at zero or minimum intensity.