

Ned. Ver. v. Historie v/d Radio

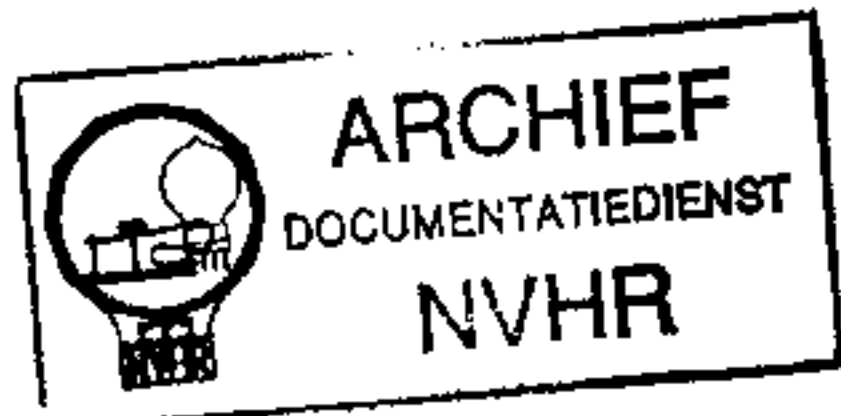

# EKCO AW87 AND CTA87 CONSOLE

REVISED ISSUE OF SERVICE SHEET No. 222

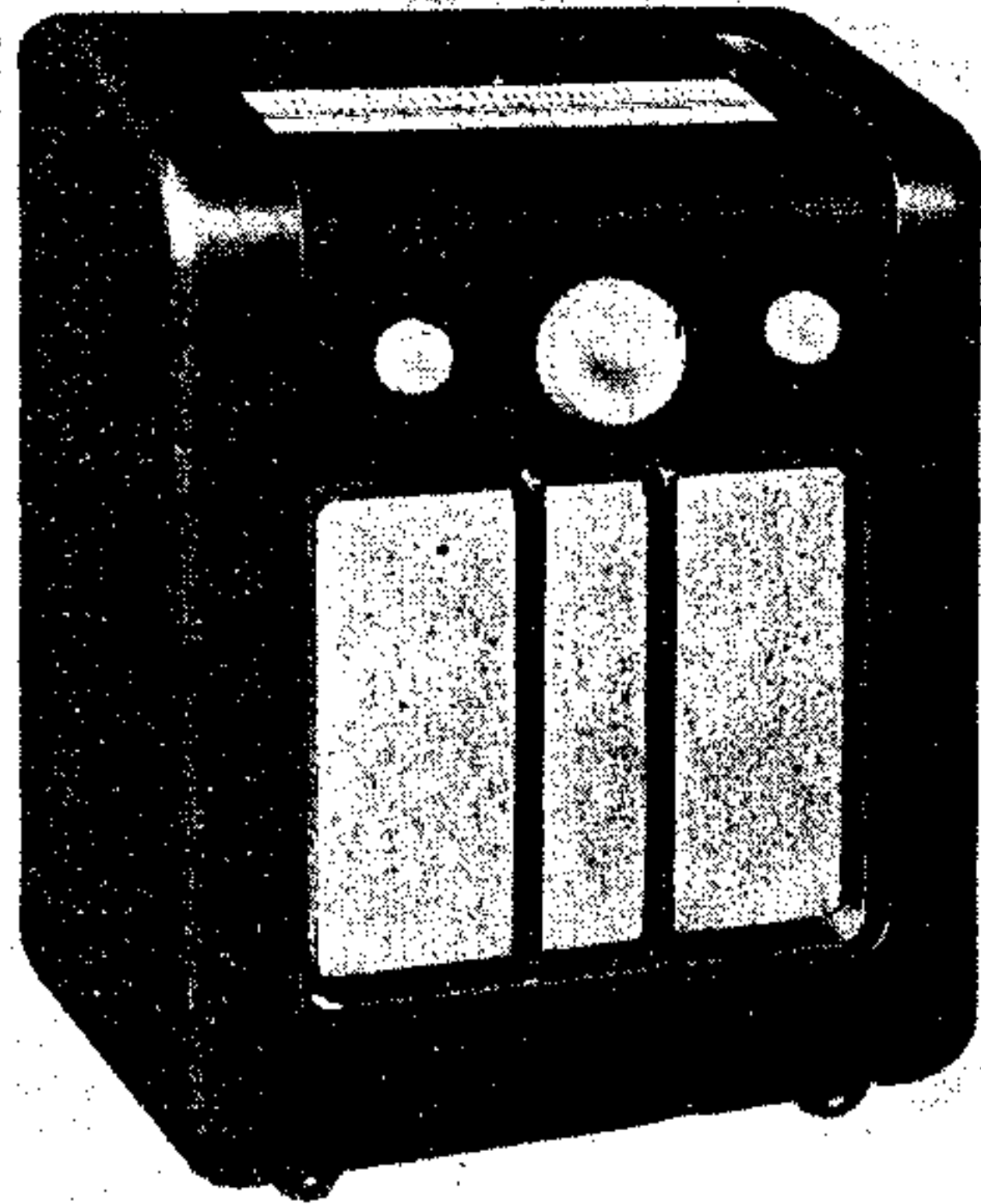

**T**HREE wavebands are provided in the Ekco AW87, the SW range being 19.50 m. Two sockets are fitted for a doublet aerial on the SW band. The set is available in walnut or black and ivory finish.

The chassis is divided into three sections, interconnected via two rows of tags. It is designed to operate from AC mains of 200-250 V, 40-80 c/s. There is provision for a gramophone pick-up and a low impedance external speaker.

An identical chassis is used in the CTA87 console.

Release date, both models: July, 1936.

Original prices: A W87, walnut, £12 12s.; black and ivory, £12 19s. 6d. CTA87, £15 15s.

### CIRCUIT DESCRIPTION

Aerial input on MW and LW is from socket A1 via coupling coils L1 (MW) and L2 (LW) to inductively coupled band-pass filter. Primary coils L3, L4 are tuned by C30; secondary coils L7, L8 are tuned by C34. Coupling by mutual inductance of primary and secondary windings. Socket A2 should be connected to socket E, as indicated by the dotted line in our circuit diagram.

On SW, a doublet, or dipole aerial should be used, connected to sockets A1 and A2, as the input impedance on SW is low. The shorting strap between A2 and E should be removed, and E should be connected to earth as usual. Input is then via L5 to single tuned circuit L6, C34. If a doublet aerial is not available, the same method of connection as explained for MW and LW may be employed.

First valve (V1, Mullard metallised TH4) is a triode-hexode operating as frequency changer with internal coupling. Oscillator grid coils L9 (SW), L11 (MW) and L13 (LW) are tuned by C36; parallel trimming by C40 (SW), C10, C41 (MW) and C12, C42 (LW); series tracking by C37 (SW), C11, C38 (MW) and C39 (LW). Reaction coupling from anode is applied via coils L10 (SW), L12 (MW) and L14 (LW), and on each band additional coupling is afforded by including the common impedance of the trackers in grid in anode circuits.

Second valve, a variable-mu RF pentode (V2, Ekco metallised VP41 or Mullard metallised VP4B) operates as intermediate frequency amplifier with tuned-primary tuned-secondary transformer

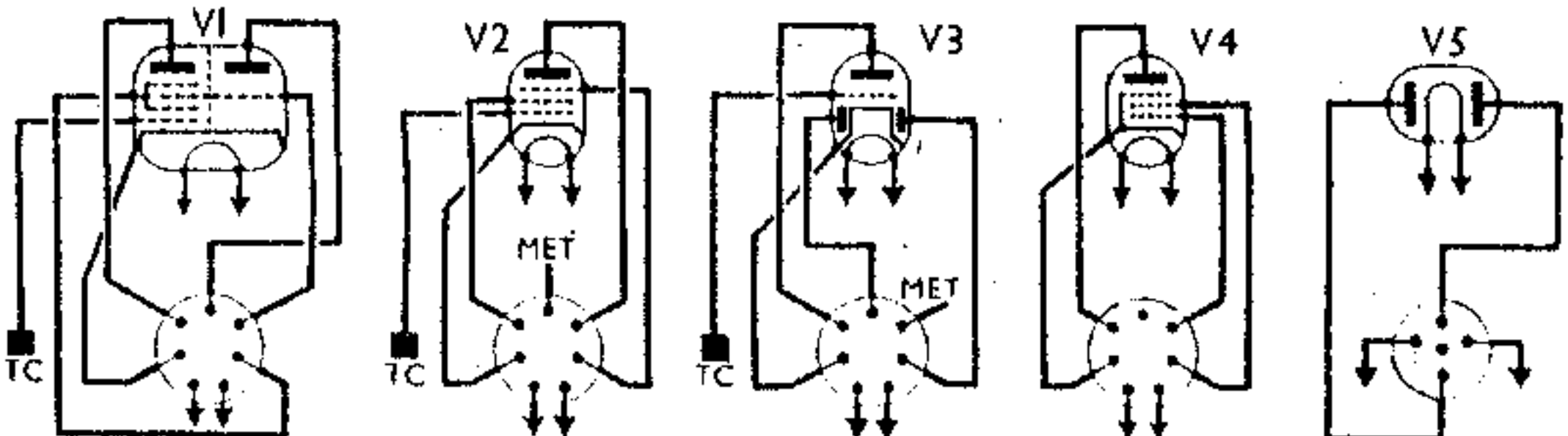
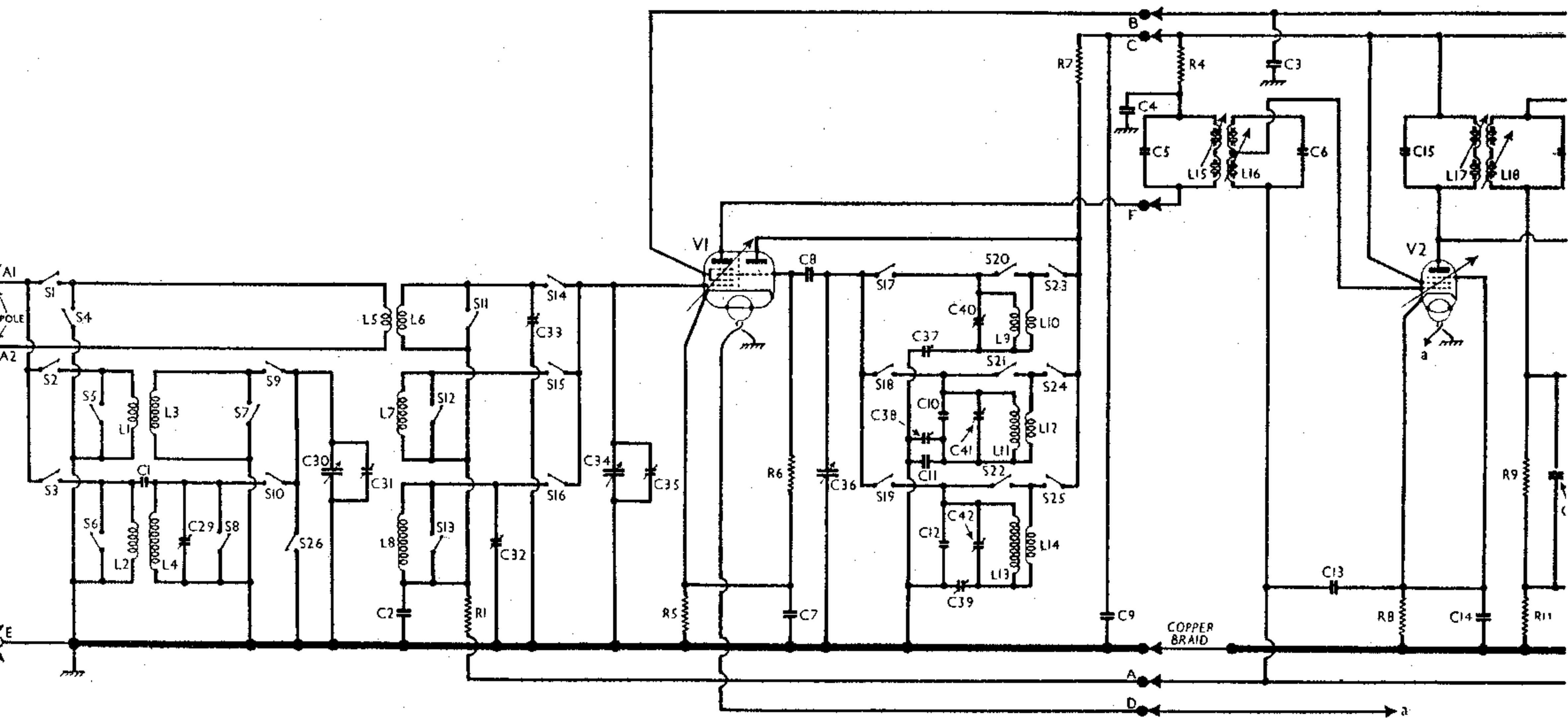

Circuit diagram of the Ekco AW87 (table) and CTA87 (console) AC set with a normal aerial, the aerial should be connected to socket A1, and strapped to E as indicated by the dotted lines. Where a doublet aerial SW work, the strap should be removed, and the two aerial leads should be connected to sockets A2 and E. The RF sub-chassis (left of centre-line) is connected to the main chassis (right of centre-line) via tags 1-11.

Plan view of the chassis. The coil adjustments for the IF transformers L15, L16 and L17, L18 are reached through holes in the sides of the cans. L16 is above L15, and L17 is above L18.

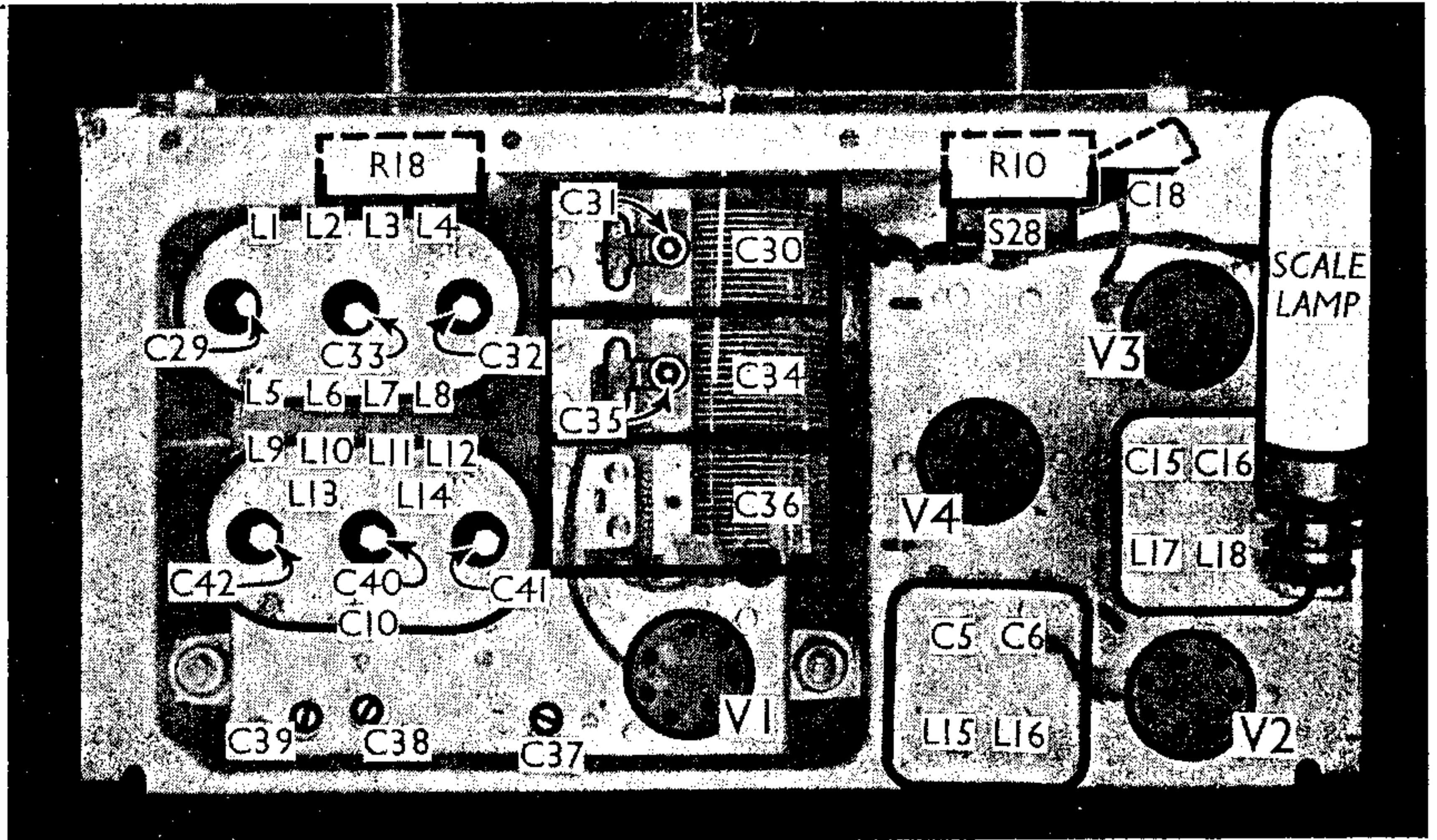

couplings C5, L15, L16, C6 and C15, L17, L18, C16, the inductances being variable. Intermediate frequency 460 KC/S. Diode second detector is part of double-diode triode valve (V3, Mullard metallised TDD4). Audio frequency component in rectified output is developed across load

resistor R9 and passed via coupling condenser C18 and manual volume control R10 to CG of triode section, which operates as AF amplifier. IF filtering by C17. Provision for connection of gramophone pick-up across C18, R10.

Second diode of V3, fed from V2 anode via C19, provides DC potential which is developed across load resistors R14, R15 and fed back from a tapping at their junction through decoupling circuits as GB to FC and IF valves, giving automatic volume control. As R14, R15 are returned to the cathode, no delay is imposed on AVC action, but the positive bias thus applied via the AVC line slightly offsets the negative bias obtained from their cathode resistors R5, R8.

Resistance-capacity coupling by R13, C22 and R16 between V3 triode and pentode output valve (V4, Mullard PenA4). Fixed tone correction by C23 in grid circuit and C25 across primary of T1; variable tone control in anode circuit by RC filter C26, R18. Provision for connection of low-impedance external speaker across secondary of T1. Screw operated switch S27 permits the internal speaker speech coil circuit to be broken.

HT current supplied by IHC full-wave rectifying valve (V5, Mullard IW4/350). Smoothing by speaker field L21, wet electrolytic condenser C27 and dry electrolytic condenser C28. RF filtering by C9.

COMPONENTS AND VALUES

RESISTORS		Values (ohms)
R1	V1 hex. CG decoupling...	100,000
R2	V1 hexode SG potential divider	10,000
R3		8,000
R4	V1 hex. anode decoupling	1,000
R5	V1 fixed GB resistor	320
R6	V1 osc. CG resistor	25,000
R7	V1 osc. anode HT feed resistor	25,000
R8	V2 fixed GB resistor	500
R9	V3 signal diode load	500,000
R10	Manual volume control	250,000
R11	V3 triode GB resistor	750
R12	V3 triode anode decoupling	10,000
R13	V3 triode anode load	50,000
R14	V3 AVC diode load resistors	250,000
R15		500,000
R16	V4 CG resistor	500,000
R17	V4 GB resistor	160
R18	Variable tone control	250,000

CONDENSERS		Values (µF)
C1	LW top coupling	0.00002
C2	V1 hex. CG decoupling	0.02
C3	V1 hex. SG decoupling	0.1
C4	V1 hex. anode decoupling	0.02
C5	1st IF trans. pri. tuning	0.000045
C6	1st IF trans. sec. tuning	0.000062
C7	V1 cathode by-pass	0.1
C8	V1 osc. CG condenser	0.0001
C9	HT circuit RF by-pass	0.25
C10	Osc. MW fixed trimmer	0.00001
C11	Osc. MW fixed tracker	0.00033
C12	Osc. LW fixed trimmer	0.00004
C13	V2 CG decoupling	0.02
C14	V2 cathode by-pass	0.1
C15	2nd IF trans. pri. tuning	0.000048
C16	2nd IF trans. sec. tuning	0.000058
C17	IF by-pass	0.0005
C18	AF coupling to V3	p.02
C19	Coupling to V3 AVC diode	0.000005
C20*	V3 anode decoupling	2.0
C21*	V3 cathode by-pass	25.0
C22	V3 to V4 AF coupling	0.02
C23	Fixed tone corrector	0.0005
C24*	V4 cathode by-pass	25.0
C25	Fixed tone corrector	0.005
C26	Part of tone control	0.02
C27*	HT smoothing condensers	8.0
C28*		8.0
C29†	B-P pri. LW trimmer	—
C30†	Band-pass pri. tuning	—

\* Electrolytic. † Variable. ‡ Pre-set.

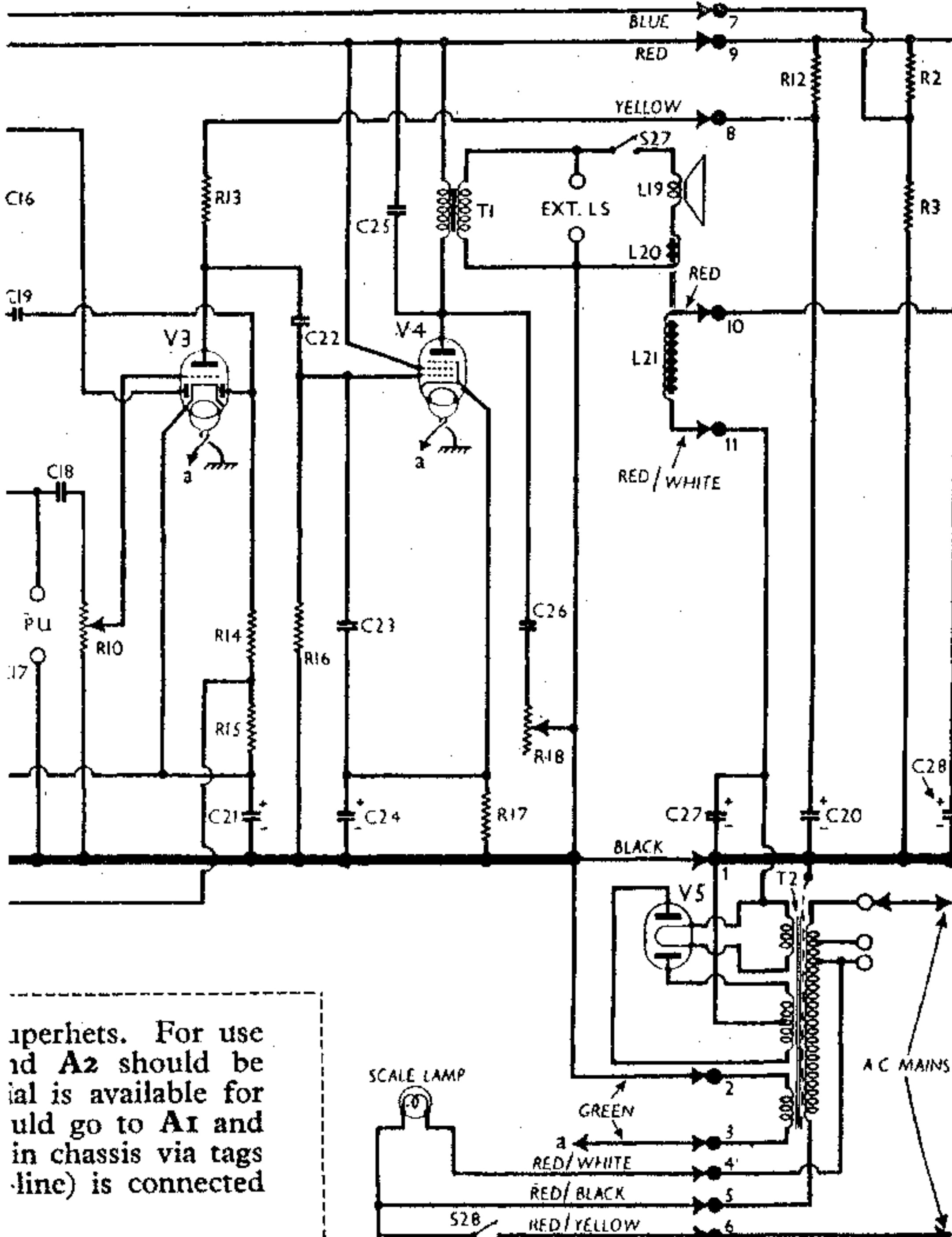

perhets. For use and A2 should be available for uld go to A1 and in chassis via tags (line) is connected

Switch Table and Diagrams

CONDENSERS (continued)		Values (μF)
C31†	B-P pri. MW trimmer ...	—
C32†	B-P sec. LW trimmer ...	—
C33†	Aerial circ. SW trimmer	—
C34†	B-P sec. and SW tuning	—
C35†	B-P sec. MW trimmer ...	—
C36†	Osc. circuit tuning ...	—
C37†	Osc. SW tracker ...	—
C38†	Osc. MW tracker ...	—
C39†	Osc. LW tracker ...	—
C40†	Osc. SW trimmer ...	—
C41†	Osc. MW trimmer ...	—
C42†	Osc. LW trimmer ...	—

\* Electrolytic. † Variable. ‡ Pre-set.

OTHER COMPONENTS		Approx. Values (ohms)	
L1	Aerial MW coupling coil...	27.0	
L2	Aerial LW coupling coil...	150.0	
L3	Band-pass primary coils...	2.8	
L4		21.0	
L5	Aerial SW coupling coil...	0.1	
L6	Aerial SW tuning coil ...	Very low	
L7	Band-pass secondary coils	3.0	
L8		19.5	
L9	Osc. SW tuning coil ...	Very low	
L10	Osc. SW reaction...	0.1	
L11	Osc. MW tuning coil ...	1.2	
L12	Osc. MW reaction ...	0.5	
L13	Osc. LW tuning coil ...	7.75	
L14	Osc. LW reaction ...	2.3	
L15	1st IF trans. { Pri. ...	15.0	
L16		Sec. total ...	15.0
L17	2nd IF trans. { Pri. ...	15.0	
L18		Sec. ...	15.0
L19	Speaker speech coil ...	1.6	
L20	Hum neutralising coil ...	0.1	
L21	Speaker field coil ...	2,250.0	
T1	Output trans. { Pri. ...	700.0	
T2	Mains trans. { Heater sec. ...	0.075	
		Rect. heat. sec. ...	0.125
		HT sec. total...	600.0
S1-S26	Waveband switches ...	—	
S27	Internal speaker switch ...	—	
S28	Mains switch, ganged R10	—	

Switch	MW	SW	LW
S1	—	○	—
S2	—	○	—
S3	—	○	—
S4	—	○	—
S5	—	○	—
S6	—	○	—
S7	—	○	—
S8	—	○	—
S9	—	○	—
S10	—	○	—
S11	—	○	—
S12	—	○	—
S13	—	○	—
S14	—	○	—
S15	—	○	—
S16	—	○	—
S17	—	○	—
S18	—	○	—
S19	—	○	—
S20	—	○	—
S21	—	○	—
S22	—	○	—
S23	—	○	—
S24	—	○	—
S25	—	○	—
S26	—	○	—

tent of the speech coil leads, or freed entirely by unsoldering these from the external speaker sockets and unsoldering from the rear of the power unit the chassis connecting strip. As the tags on this strip are rigidly mounted, they must be separated by inserting some normally unsolderable material between them as they are unsoldered one by one, while the solder is still hot. A small strip of aluminium is very suitable.

When replacing, the black speaker lead should go to the pick-up socket which is connected to chassis, and the blue one to the tag which is in contact with S27.

The tags of the chassis connecting strip should be so positioned that the left-hand end tag of the strip is opposite that on the power unit (tag No. 1 in our illustration). The remainder then meet their correct opposite numbers automatically.

Check the calibration before replacing chassis in cabinet. When the gang is turned to maximum capacity, the scale pointer slide should be exactly 1/32in. from the slide support. If necessary, adjust it by sliding the pointer along the drive cord.

Removing Power Unit.—Remove the cheese-head screw (with lock-washer) holding the bracket on the deck to the speaker magnet; remove the four screws (with washers) holding the unit to the bottom of the cabinet; if necessary, unsolder the connections to the tags at the rear of the unit.

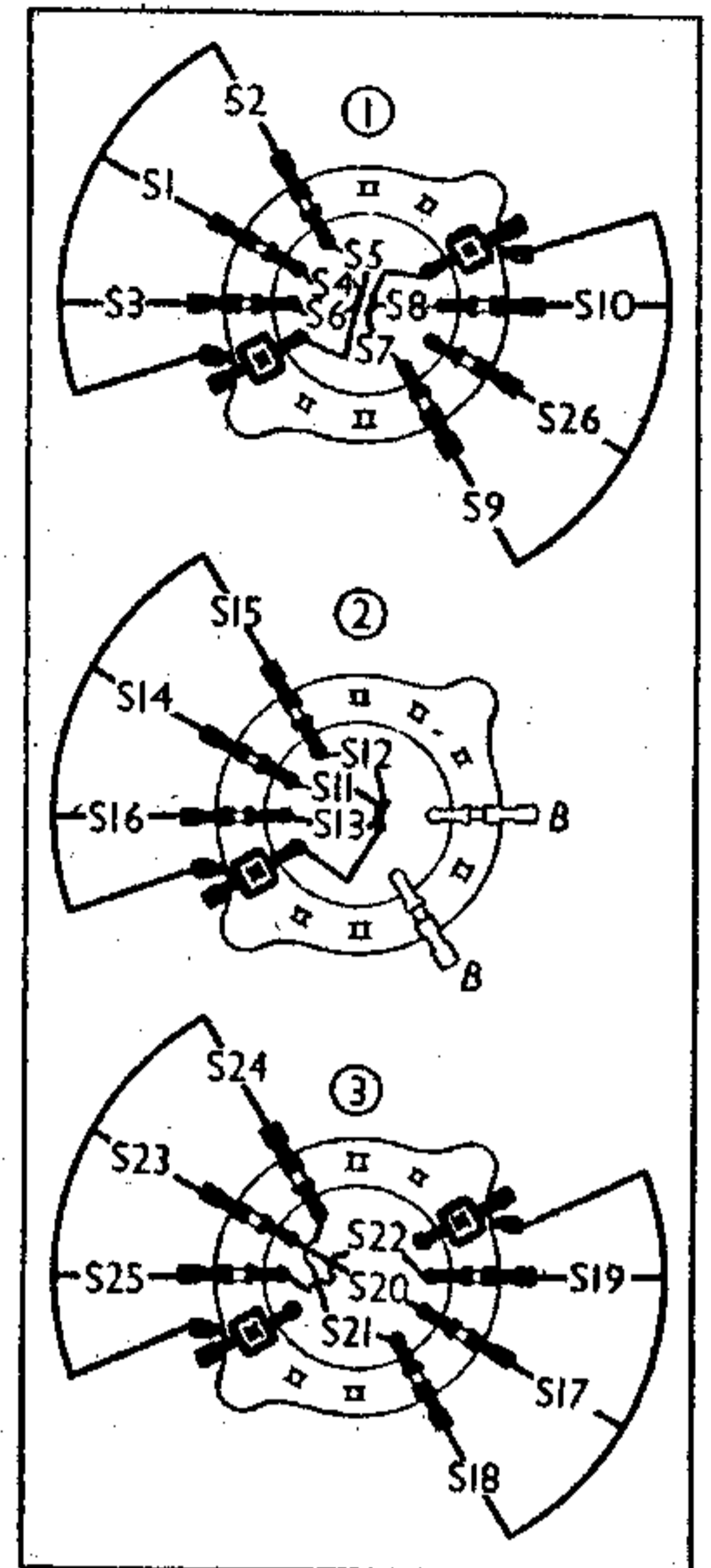

Waveband switch diagrams, as seen in the direction of the arrows in our under-chassis view.

When replacing; the chassis strip should be connected as previously described. The red speaker field lead goes to tag No. 10 on the unit, and the red and white lead goes to tag No. 11.

Removing Speaker.—Remove the chassis and power unit as previously described; remove the four self-tapping bolts (with washers) holding the sub-baffle to the front of the cabinet. The speaker may be separated from the sub-baffle if the nuts (with washers and lock-nuts) are removed from the four fixing screws.

When replacing, the connecting panel should be at the bottom. If the leads have been unsoldered, they should be connected as follows, numbering the tags from left to right: 1, red; 2, black; 3, blue (or green); 4, no external connection; 5 red (or red/white).

DISMANTLING THE SET

Removing Receiver Chassis.—Remove the three control knobs (recessed grub screws) from the front of the cabinet, and the switch knob (screw inside cabinet) from the side; remove two cheese-head screws (with lock-washers) holding the chassis to the front of the cabinet, and two more (with washers and lock-washers) at the rear. The chassis may now be withdrawn to the ex-

VALVE ANALYSIS

Valve voltages and currents given in the table below are those measured in our receiver when it was operating on mains of 230 V, using the 220-230 V tapping on the mains transformer. The receiver was tuned to the lowest wavelength on the medium band and the volume control was at maximum. There was no signal input.

Voltages were measured on the 1,200 V scale of an Avometer, chassis being negative.

Valve	Anode Voltage (V)	Anode Current (mA)	Screen Voltage (V)	Screen Current (mA)
V1 TH4	245	2.5	80	4.8
	Oscillator	5.8		
V2 VP41	245	8.0	245	3.5
V3 TDD4	90	2.7	—	—
V4 PenA4	225	32.0	245	4.0
V5 1W4/350	345†	—	—	—

† Each anode, AC.

GENERAL NOTES

Switches.—S1-S26 are the waveband and radio muting switches, in three ganged rotary units beneath the RF sub-chassis. The units are indicated in our under-chassis view, and are shown in

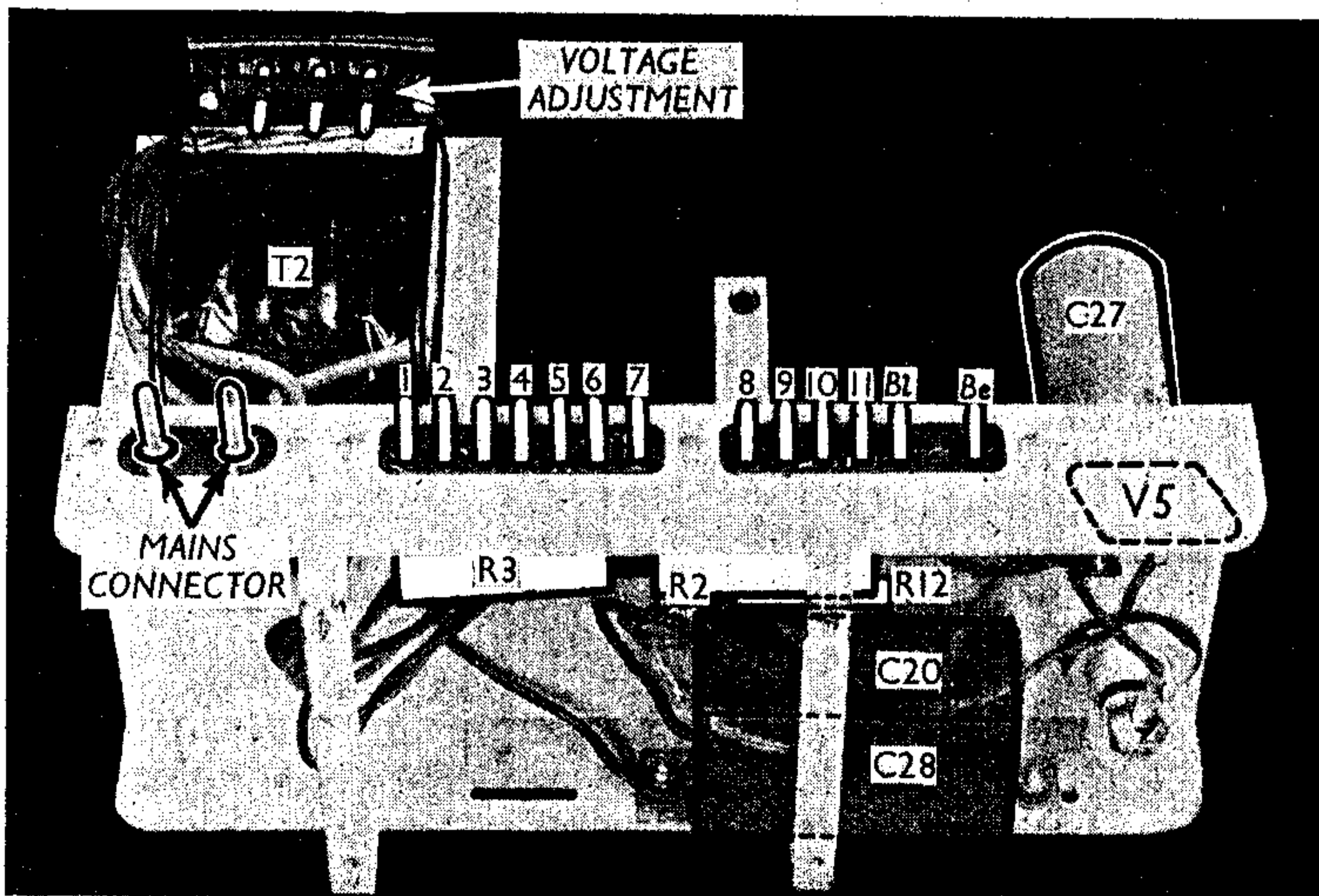

Three-quarter rear view of the power unit, showing the connecting tags.

Under - chassis view. The three wave band switch units are indicated on the right by numbers in circles and arrows which show the direction in which they are viewed in the diagrams in col. 3. The cable to the power unit can be seen running off the front of the chassis:

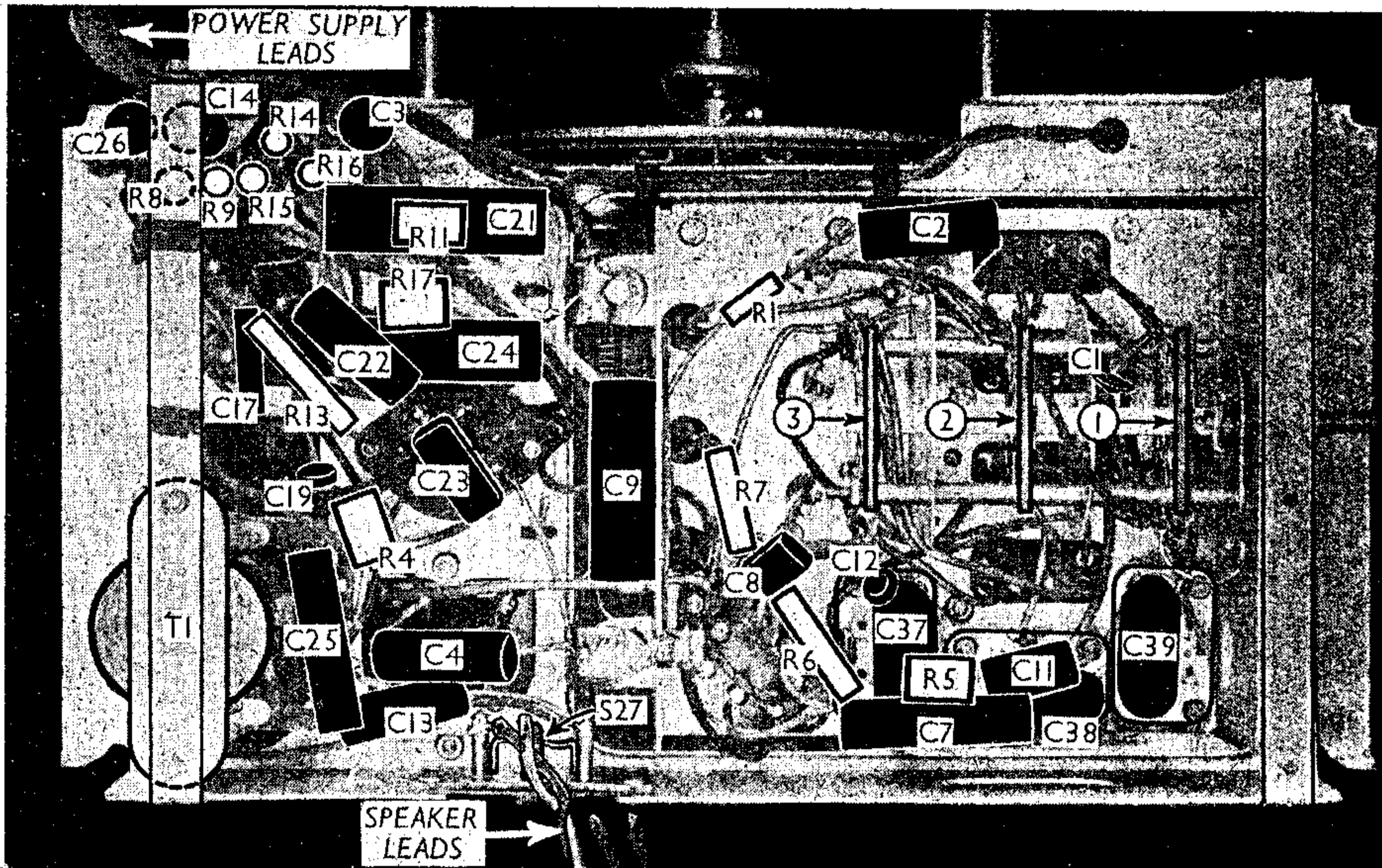

detail in the diagrams (col. 3) where they are seen looking from the output end of the underside of the chassis. Split contact plates on the rotors add considerably to the number of switches. All are indicated in our circuit and switch diagrams. The table (col. 2) gives the switch positions for the three control settings, starting from fully anti-clockwise. A dash indicates open, and C, closed.

**S27** is the internal speaker switch, opened by unscrewing the small knob beneath the EXT. LS sockets. **S28** is the QMB mains switch, ganged with the volume control **R10**.

**Coils.**—All the RF and oscillator coils are in the two screened units on the deck of the sub-chassis. The IF transformers, **L15**, **L16** and **L17**, **L18** are in two screened units on the main chassis deck. They are tuned by fixed condensers and variable inductances, the adjusting screws projecting through slots in the sides of the screens. In the **L15**, **L16** unit the primary adjuster is below the secondary, and in the **L17**, **L18** unit it is above the secondary.

**Scale Lamp.**—This is a special Ensign tubular type, with a centre contact SB cap. It is rated at 200 V, 12 W, and is so connected across the primary of **T2** that it always receives the correct voltage when the voltage adjustment of the receiver is correct for the mains in use.

**External Speaker.**—Two sockets are provided at the rear of the chassis for a low impedance (about 3 Ω) external speaker. The internal speaker may be silenced by unscrewing the knob of **S27**.

**Aerial-Earth Connections.**—For a normal aerial, use socket **A1**, and short-circuit **A2** and **E** with the clip provided, **E** being connected to earth.

For a doublet aerial (two wires, each 20.5 or 41 ft. long, with a twisted feeder) use **A1** and **A2**, with **E** connected to earth only.

**Inter-chassis Connections.**—Apart from the cabinet, this receiver comprises four separate units: the main receiver chassis, and a sub-chassis, carrying the entire RF and oscillator circuits, mounted on the receiver chassis; the power unit; and the speaker assembly. Each of these is connected via flexible leads and a row of connecting tags.

The RF sub-chassis has a row of six tags on the side near the centre of the main chassis, just below **C9**. These are not shown in our chassis illustrations, but they are indicated in the circuit diagram by the letters **A** to **F**; the tags themselves run in alphabetical order from front to rear. **E** does not appear in the circuit diagram, and in the chassis it is blank; there is a gap, also, between **E** and **F**. The connection between the two chassis pressings is effected by a piece of copper braiding.

The power unit has a row of thirteen tags projecting from its rear member, and eleven of these are connected via a cable to the main receiver chassis, as explained under "Dismantling the Set." The tags are identified in our illustration of the unit. One tag is blank (**B1**) and another is used as a bearer (**Be**) to support the end of the paxolin strip which terminates the power unit cable from the main chassis. There are ten tags on this strip, which are soldered direct to the corresponding tags on the power supply unit. The blank tag, and tags 10 and 11 on the unit, have no corresponding tags on the strip. Tags 9 and 10 are joined together.

In the case of these tags, as also in the case of the sub-chassis connections, the division between the separate units is indicated in the circuit diagram by a vertical row of arrows and solid circles.

The speaker speech coil is connected directly to the Ext. LS panel on the main chassis. The field coil **L21** is connected to tags 10 and 11 on the power unit.

**Chassis Divergence.**—In our chassis, **C1** and **C10** had the values shown in our tables: 0.00002 (20 μμF) and 0.00001 (10 μμF). In the makers' information these two values are transposed.

### CIRCUIT ALIGNMENT

**IF Stages.**—Connect a signal generator to the grid (top cap) of **V1** via a 0.01 μF condenser, and chassis. Leave the normal grid lead connected.

Turn receiver volume control to maximum. Feed in a 460 kc/s signal, and adjust the screws associated with the inductors **L15**, **L16**, **L17** and **L18** in that order for maximum output, keeping the input low to avoid AVC action. Repeat the adjustments until no further improvement results.

**RF and Oscillator Stages.**—With the gang at maximum, the pointer should cover the 1,950 m mark on the scale. Connect signal generator via a suitable dummy aerial to **A1** and **E** sockets.

**MW.**—Switch set to MW, tune to 200 m on scale, feed in a 200 m (1,500 kc/s) signal, fully unscrew **C41**, and then screw it up slowly until a peak is reached, finally adjusting it for maximum output. Tune to 550 m on scale, feed in a 550 m (545 kc/s) signal, and adjust **C31** and **C35** for maximum output, rocking the gang for optimum results; then adjust **C38** for maximum output, still rocking the gang. Return to 200 m, and check the setting of **C31** and **C35**.

**LW.**—Switch set to LW, tune to 1,000 m on scale, feed in a 1,000 m (300 kc/s) signal, and adjust **C42** for maximum output. Tune to 1,700 m on scale, feed in a 1,700 m (176.3 kc/s) signal, and adjust **C29** and **C32** for maximum output, rocking the gang for optimum results; then adjust **C39** for maximum output, still rocking the gang. Return to 1,000 m, and check the setting of **C29** and **C32**.

**SW.**—Switch set to SW, and see that **A2** is connected to **E**. Tune to 15 Mc/s on scale, feed in a 15 Mc/s (20 m) signal, and adjust **C40** for maximum output. Two settings will be found, and that involving the lesser trimmer capacity should be selected. The image should now be found at 14.1 Mc/s on scale (using a strong signal); if it is found instead at 15.9 Mc/s, the wrong peak has been used. Now adjust **C33**, with weak input again, while rocking the gang. Tune to 14.1 Mc/s on scale, where 15 Mc/s signal should be weak compared with that at correct tuning point. If it is strong, readjust **C33**.

Tune to 6 Mc/s on scale, feed in a 6 Mc/s (50 m) signal, and adjust **C37** for maximum output while rocking the gang for optimum results. Return to 15 Mc/s, and readjust **C33** for maximum output.