

MODEL A104 is a five-valve, including rectifier, superheterodyne receiver covering short, medium and long wavebands and operates from A.C. mains only.

MODEL U109 is an AC/DC version of the A104 and operates from either A.C. or D.C. mains.

MODEL A129 is an export version of the A104 and operates from A.C. mains only. A continental tuning scale is fitted and the mains transformer has additional primary tapings to afford 100-135 volts operation.

MAINS SUPPLY. A104 — — 200 — 250 volts, 40-100 cps.
U109 — — 200 — 250 volts, A.C. or D.C.
A129 — — 100 — 135 volts, 200-250 volts,
40-100 cps.

CONSUMPTION. A104-A129—258 m.a. at 225 volts (T2 primary current).
U109 A.C. — 243 m.a. at 225 volts.
U109 D.C. — 165 m.a. at 220 volts.

CONTROLS. All three models. There are four controls positioned across the lower front of the cabinet and from left to right are : TONE. VOLUME ON/OFF. TUNING. WAVECHANGE SWITCH.

VALVES. All three models. V1—UCH42—Frequency changer. V2—UF41—I.F. amplifier. V3—UBC41—Demodulator, A.V.C. A.F. amplifier. V4—UL41—A.F. amplifier. V5—UY41—Half-wave rectifier.

All valves are Mullard and have B8A bases.

Note. A104-A129. The five valve heaters are series fed from T2 tapped secondary.

PILOT LAMPS. A104-A129. 6.5 volts 300 m.a. M.E.S.
U109. 6.2 volts 300 m.a. M.E.S.

WAVEBANDS. All three models.

S.W.—16.0 to 51 metres. 18.75 to 5.88 Mc/s.

M.W.—185 to 570 metres. 1621 to 526 Kc/s.

L.W.—950 to 2,150 metres. 316 to 140 Kc/s.

INTERMEDIATE FREQUENCY. 460 Kc/s.

LOUD-SPEAKER IMPEDANCE. 3 ohms at 400 cps.

On the rear centre panel, the upper pair of sockets are for the connection of a low impedance, 3 ohms, extension speaker.

Immediately below is the screw type switch S6 for muting the internal speaker when an external speaker is connected.

OUTPUT. A104-A129—2.5 watts.
U109—2 watts.

PICK-UP. The lower pair of sockets on the rear centre panel are for the connection of a pick-up, the internal connections for which are completed when the wavechange switch is turned to GRAM. The "earthy" socket is shown in the diagrams.

MODEL UI09. Metal parts of the motor and pick-up must not be earthed.

CIRCUIT DETAILS. A104. Between the aerial and chassis is connected an I.F. filter LI.C1 to by-pass unwanted signals in the region of the intermediate frequency.

For each waveband, a separate grid tuning coil together with a shunt trimmer is coupled to the aerial circuit, the required coil being selected by S1.S2 and tuned by one section of the gang.

The received signal is applied to the mixer grid of V1 via the D.C. blocking condenser C9.

The oscillator circuit is the conventional parallel fed H.F. transformer type, the grid coils being shunted by trimmers for alignment.

Each pair of coils is selected by switches S3.S4, the second section of the gang tuning the grid coil.

R7 and C40 in the S.W. section are respectively damping resistor and neutralising condenser.

In a few early UI09's the S.W. trimmer C14 is not fitted.

The I.F. signal at the anode of V1 is transformer coupled by I.F.T.1 to V2, amplified, and then coupled by I.F.T.2 to a diode of V3 for demodulation.

From across the diode load R13, the signal's A.F. component feeds via R11.C30 and the volume control R12 to the triode section of V3.

After amplification by V3 the A.F. signal feeds via R21.C34 to V4 for final amplification, then transformer coupled to the permanent magnet loud-speaker.

The resistance/capacity network between the anodes of V3 and V4 provides selective frequency negative feed-back to V4 grid, varied by the setting of the tone control R25.

Pick-up switching is incorporated into the wavechange switch.

In the "gram" position, the pick-up is switched across the volume control and at the same time radio reception is effectively suppressed by the disconnection of the grid and oscillator coils and "earthing" the signal grid of V1.

A.V.C. voltage is developed by coupling a small part of the signal from V2 anode by C28 to the second diode of V3.

The rectifier output passes through a R/C filter to the grids of V1 and V2.

The secondary circuit of the mains transformer is unconventional. A low voltage winding is provided for the pilot lamps. The tapped secondary provides (a) high A.C. voltage for the half-wave rectifier anode and (b) current for the series heaters of all valves.

A129. This model is identical with the A104 except that the mains transformer primary has additional tapings to afford operation on 100-135 volts A.C. also.

An export scale replaces the home version.

U109. Circuit is basically the same as the A104 described but, being a "universal" receiver, the mains transformer is deleted and replaced by the conventional AC/DC mains circuit.

The chassis is therefore "alive" to one side of the mains and care must be exercised when handling an exposed chassis that is connected to the supply.

As a precautionary measure, check that the chassis is connected to the earthed side of A.C. mains by connecting, with insulated wire, a neon lamp between chassis and earth. If the lamp glows, reverse the mains plug.

Resistor R29, the pilot shunt, is a Thermistor, and its resistance varies with the current passing through it. Off load it measures 3,000 ohms but on load this drops to approximately 75 ohms.

Series protective condensers are included in the aerial, earth, and pick-up circuits.

POINTER SETTING. All three models. Close the gang by rotating the tuning control fully clockwise, when the pointer should coincide with the low frequency ends of the S.W., M.W. and L.W. scales.

If in error, slide the pointer saddle along the drive cord as necessary.

I.F. ALIGNMENT. All three models. Switch to M.W., fully close the gang and set the volume control to maximum.

Connect output meter to EXT.LS sockets.

Inject 460 Kc/s via a 0.1 mfd. condenser to the control grid, pin 6, of the UCH42.

Adjust the I.F.T. cores in the following order for maximum output : 2nd I.F.T. upper and lower, then 1st I.F.T. upper and lower.

Inject 460 Kc/s to the aerial socket then adjust L1 core for minimum output.

CALIBRATION. Inject signals to A and E sockets.

Switch to M.W. All three models.

Tune to and inject 1,300 Kc/s then adjust C18 for calibration and C5 for maximum output.

Tune to and inject 800 Kc/s then adjust L12 brass core for calibration.

Check calibration at 600 Kc/s. Repeat adjustments as necessary.

Switch to L.W. All three models.

Tune to and inject 250 Kc/s then adjust C21 and C7.

Check calibration at 150 Kc/s. Repeat as necessary.

Switch to S.W. All three models.

Tune to and inject 6.5 Mc/s then adjust the cores of L10 and L3.

Tune to and inject 15 Mc/s then adjust C14 and C4.

Repeat as necessary.

Switch to S.W. U109 without C14 trimmer.

Tune to and inject 6.5 Mc/s then adjust the cores of L10 and L3.

Tune to and inject 15 Mc/s then adjust C4.

Repeat as necessary.

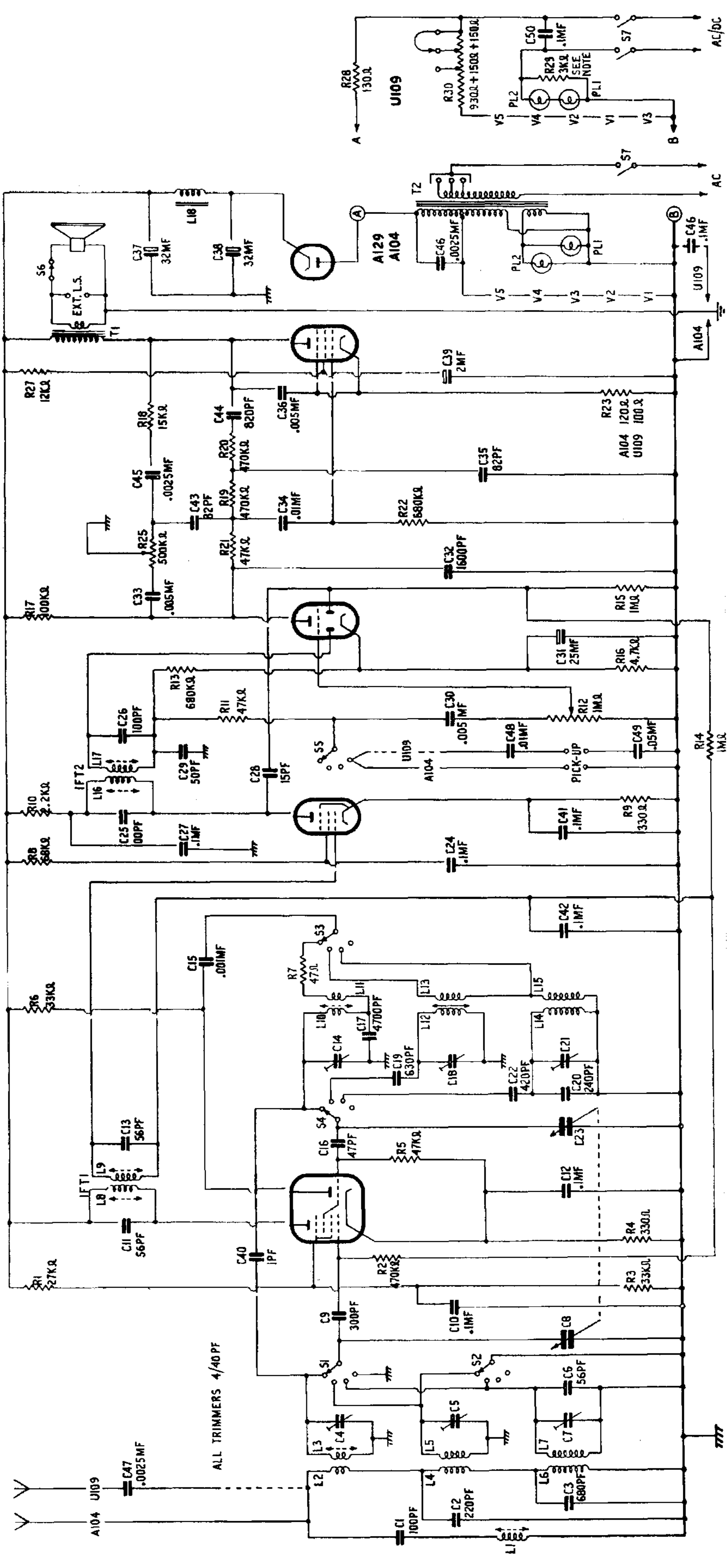

CIRCUIT DIAGRAM

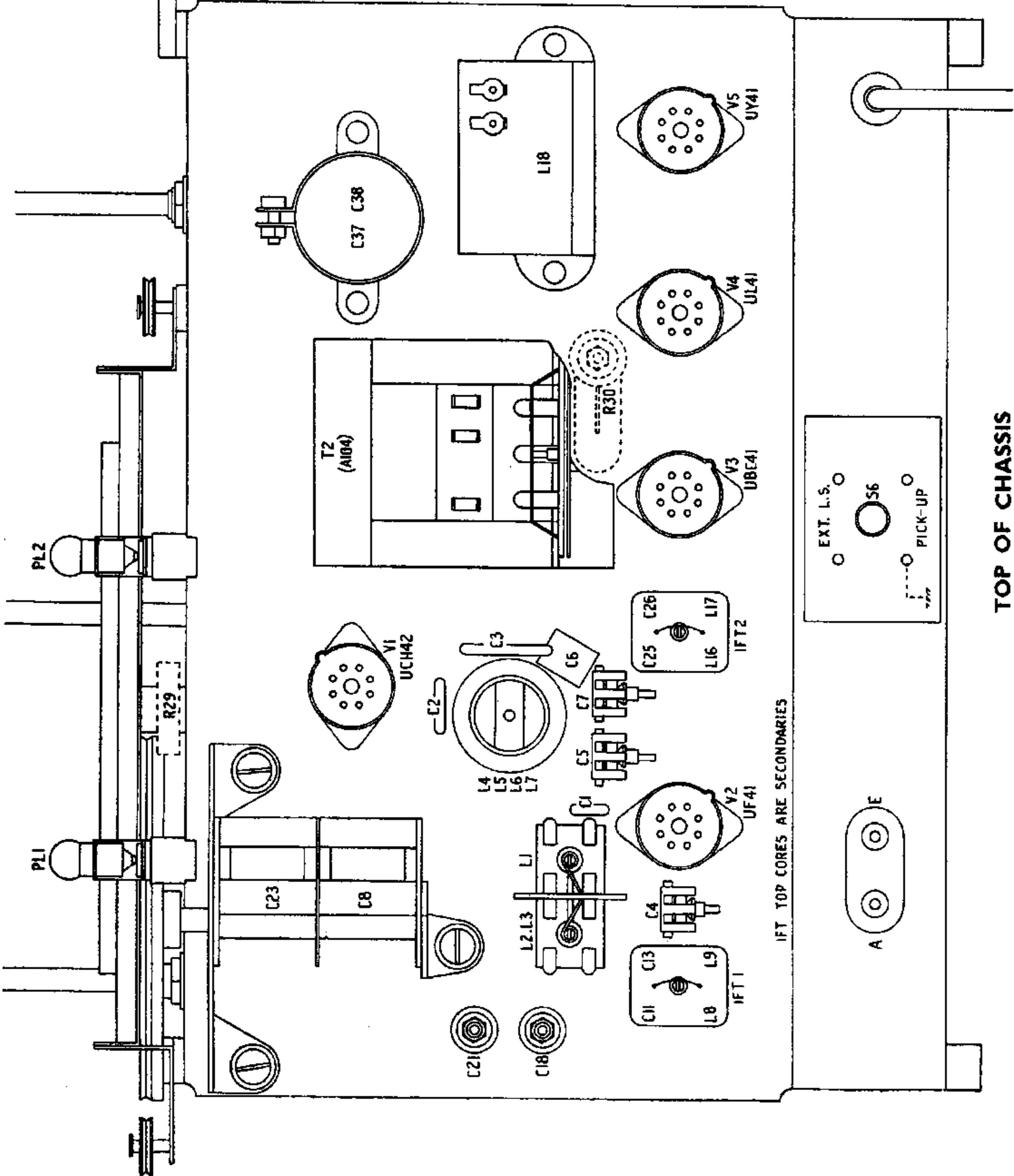

IFT TOP CORES ARE SECONDARIES

TOP OF CHASSIS

COMPONENTS SHOWN DOTTED ARE FOR U109 ONLY

DRIVE CORD/WIRE DETAILS

VIEWED WITH GANG FULLY MESHEd

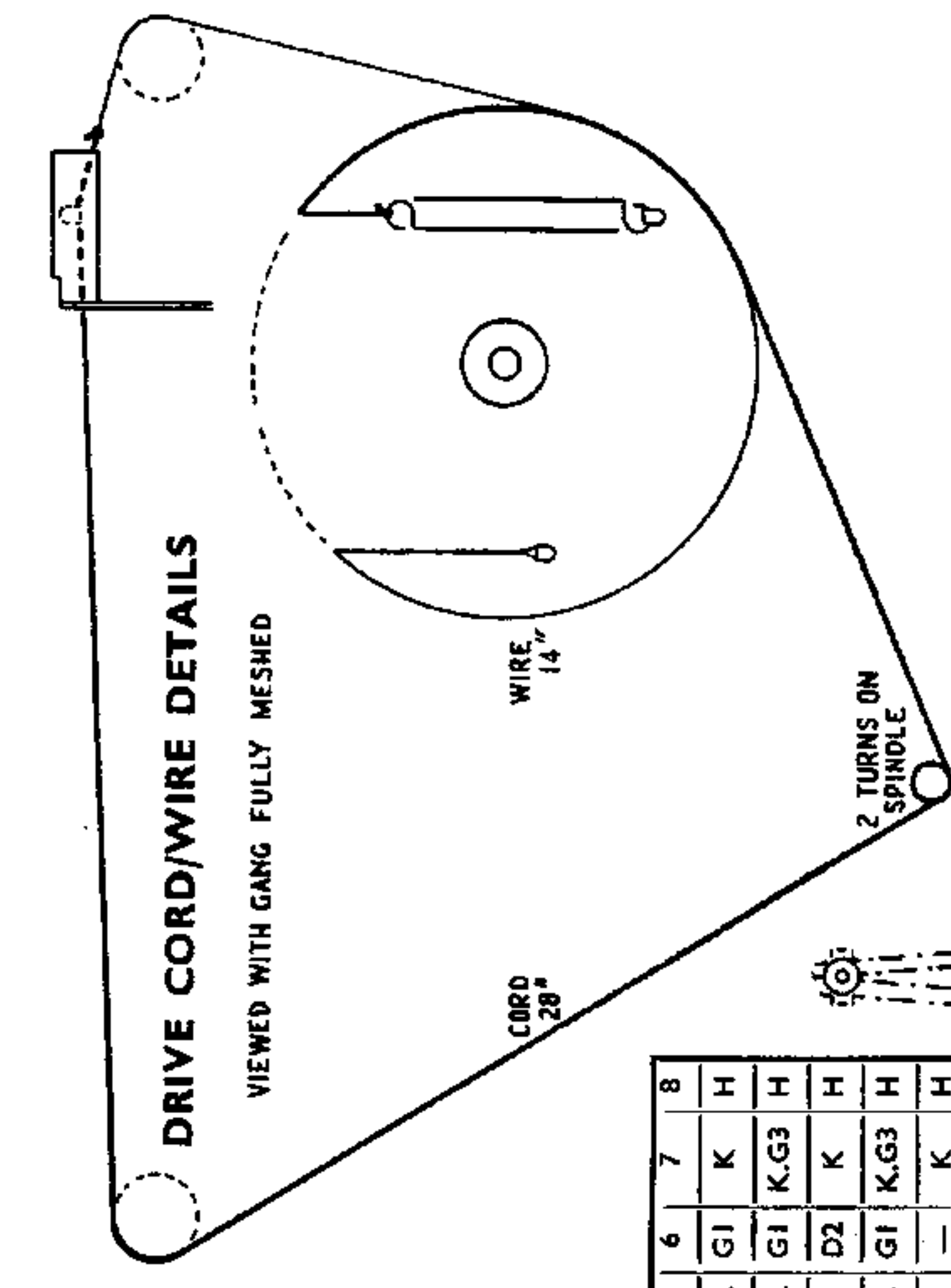

VALVE BASE DATA

valve	1	2	3	4	5	6	7	8
UCH42	H	A	OA	OG	G2	G1	K	H
UF41	H	A	—	—	G2	G1	K.G3	H
UBC41	H	A	G1	—	D1	D2	K	H
UL41	H	A	K.G3	—	G2	G1	K.G3	H
UY41	H	A	—	—	—	—	K	H

PART OF BACK COVER

SHOWING FRAME AERIAL DETAILS

STORAGE POSITION

POSITION OF LEADS AND STOWAGE MODIFIED SLIGHTLY IN LATER MODELS.

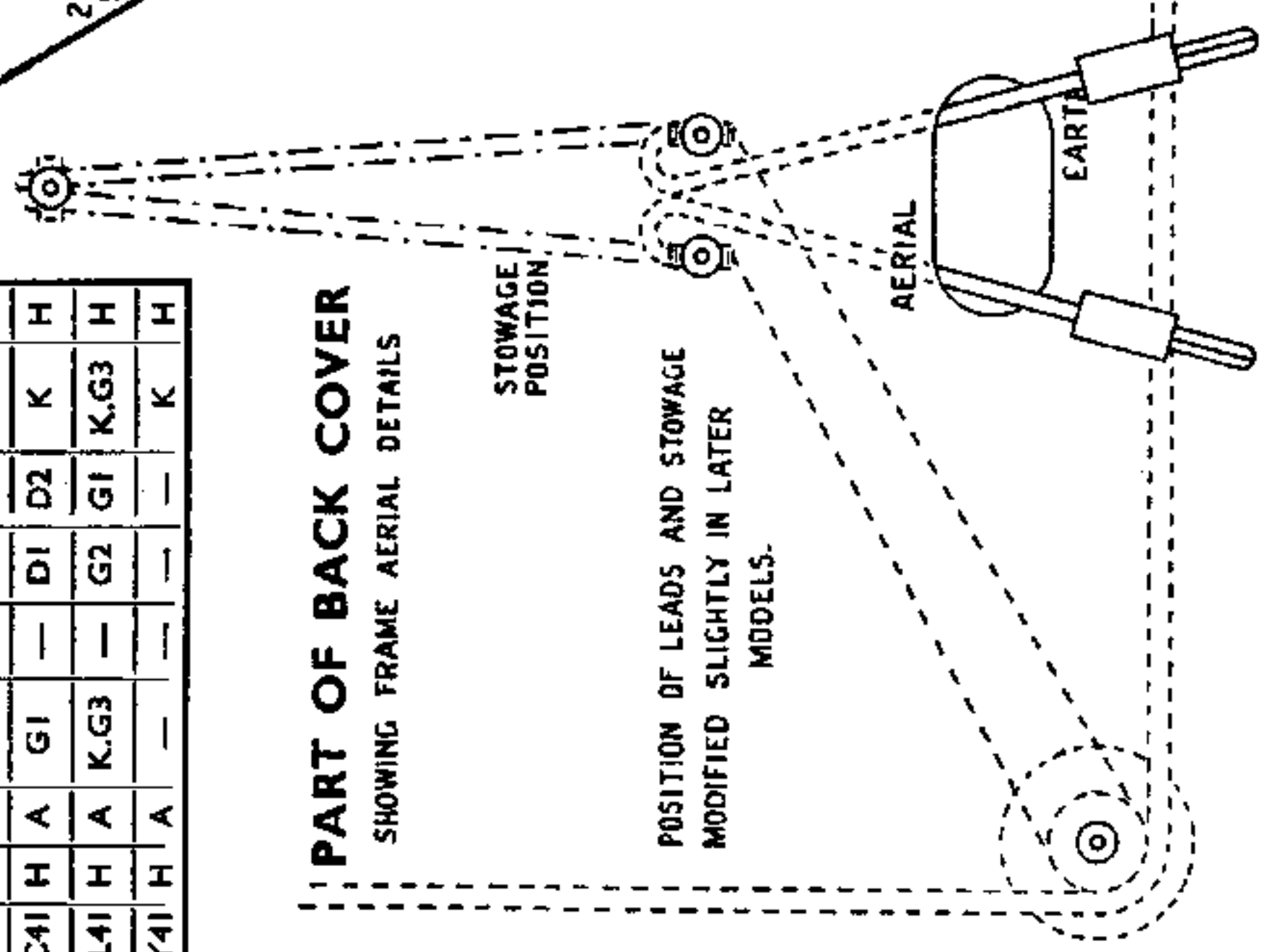

RESISTANCE OF WINDINGS

Winding	Ohms	Winding	Ohms	Winding	Ohms
L1	15	L9	33	L17	15
L2	*	L10	*	L18	350
L3	*	L11	*	T1 PRI	350
L4	18	L12	2.7	T1 SEC	*
L5	4	L13	1.7	T2 PRI	34+3+3
L6	41	L14	6	T2 SEC	72+28
L7	28	L15	1		
L8	33	L16	15		

* Less than 1 Ohm.

VOLTAGE & CURRENT DATA (A104-A129)

Valve	Anode		Screen		Cathode	
	Volts	M.A.	Volts	M.A.	Volts	M.A.
V1 Mixer	208	1.7	85	2.4	2.6	7.4
	Osc.	93	3.3	—	—	—
V2	193	5.2	97	1.6	2.2	6.8
V3	121	0.4	—	—	2.2	0.4
V4	187	49.5	106	7.0	4.6	56.5
V5	235	—	—	—	234	73.5

Set tuned to Imc. No Signal Input. 225 Volts A.C Mains Input.

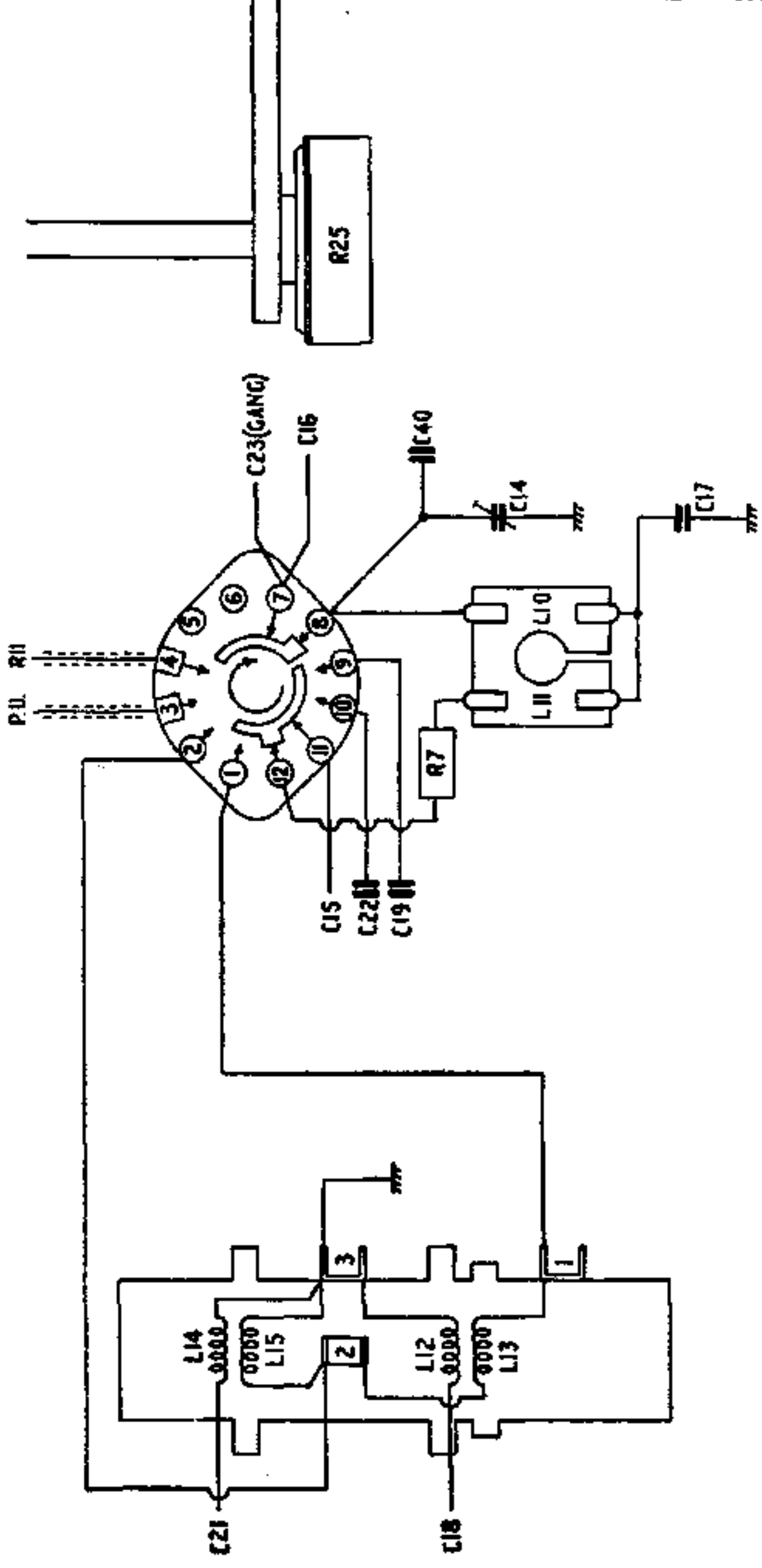

COIL AND SWITCH WIRING.

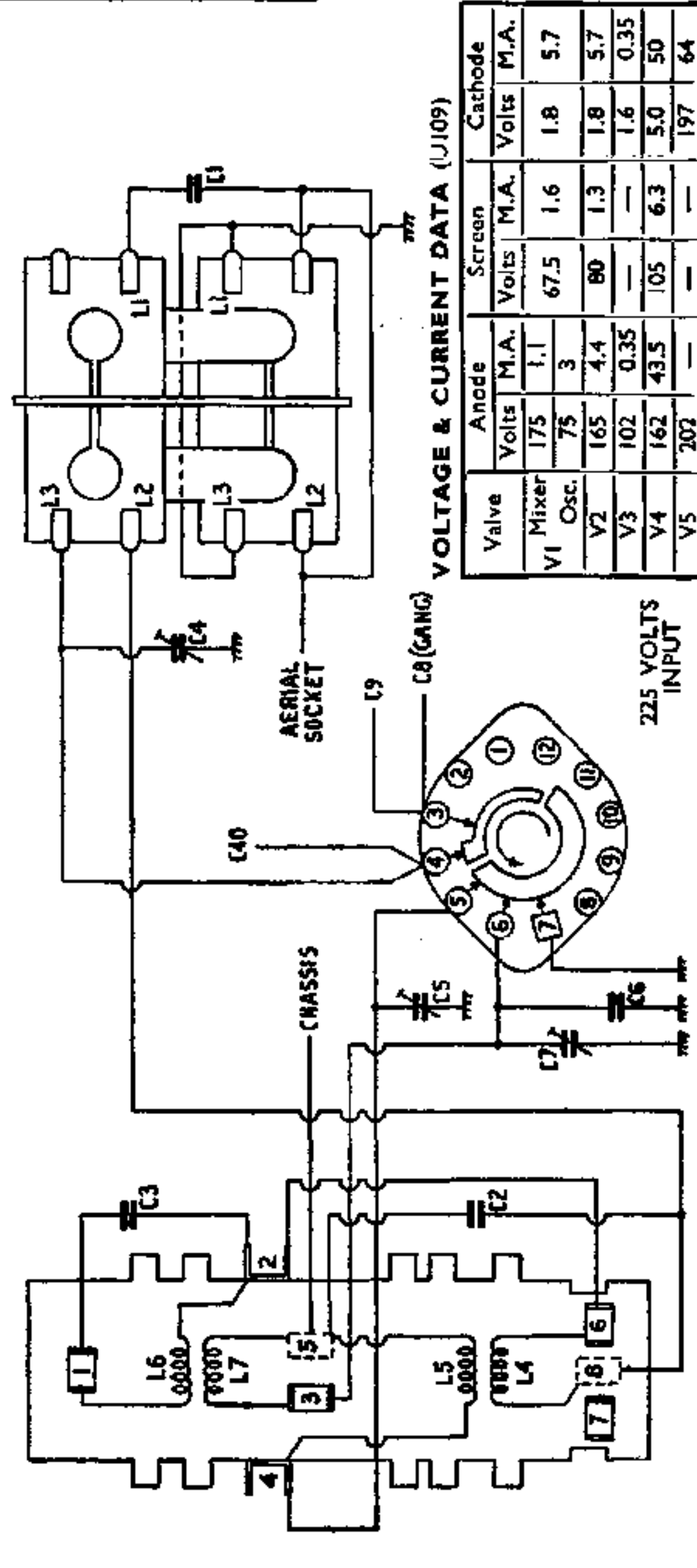

VOLTAGE & CURRENT DATA (U109)

Valve	Anode Volts	Anode M.A.	Screen Volts	Screen M.A.	Cathode Volts	Cathode M.A.
Mixer V1	175	1.1	67.5	1.6	1.8	5.7
V2	75	3	80	1.3	1.8	5.7
V3	165	4.4	—	—	1.6	0.35
V4	102	0.35	105	6.3	5.0	50
V5	162	43.5	—	—	197	64
	202	—	—	—	—	—

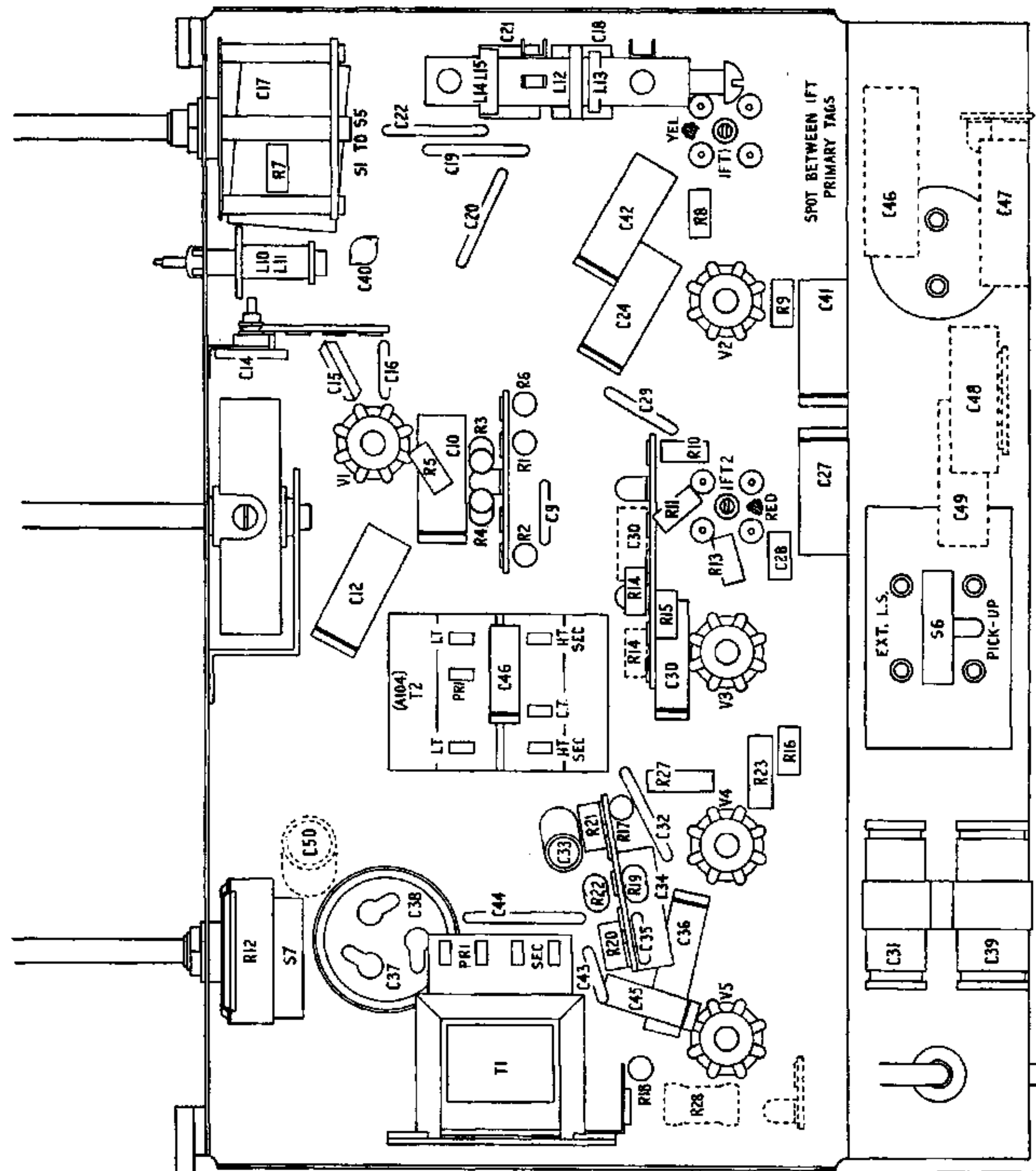

UNDERNEATH OF CHASSIS

COMPONENTS SHOWN DOTTED ARE U109 ONLY

MIDLAND SERVICE DEPOT:
11, Brook Street,
Birmingham, 3
Phone: Central 2505/6

NORTHERN SERVICE DEPOT:
55, Whitworth Street,
Manchester, 1
Phone: Central 6711/2

SCOTTISH SERVICE DEPOT:
26, India Street,
Glasgow, C.2
Phone: Central 2012

SERVICE DEPT., E. K. COLE Ltd.,
Somerton Works, Arterial Road,
Southend-on-Sea
Phone: Southend 2296
Head Office: Ekco Works, Southend-on-Sea

1. 2. 3. 4. 5. 6. 7. 8. 9. 10. 11. 12. 13. 14. 15. 16. 17. 18. 19. 20. 21. 22. 23. 24. 25. 26. 27. 28. 29. 30. 31. 32. 33. 34. 35. 36. 37. 38. 39. 40. 41. 42. 43. 44. 45. 46. 47. 48. 49. 50. 51.

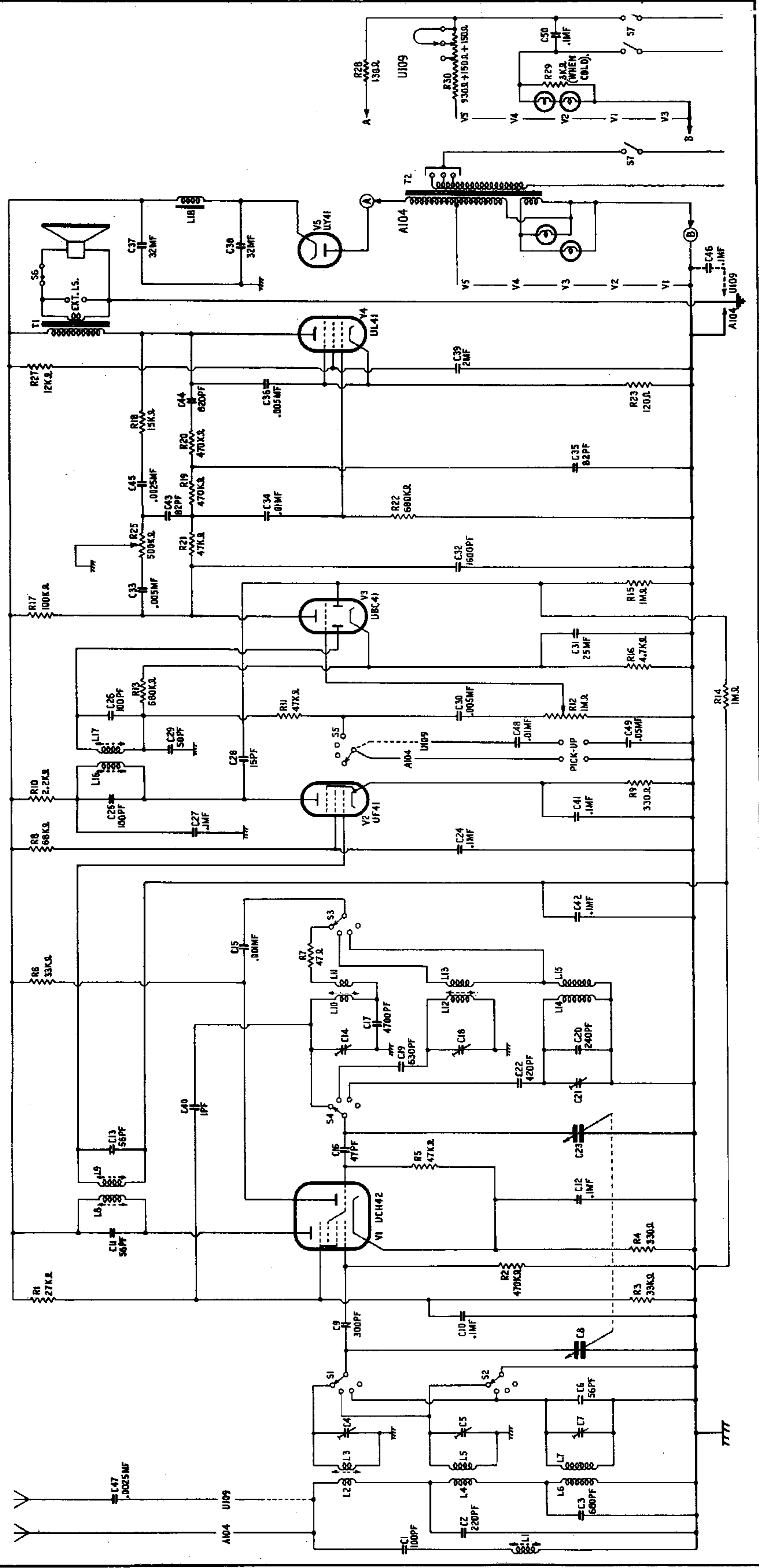

Issued by SERVICE DEPT: E. K. COLE LTD., SOMERTON WORKS, ARTERIAL ROAD, SOUTHEND-ON-SEA.

Models A104 and U109

EKCO ADVANCE SERVICE INFORMATION

EKCO ADVANCE SERVICE INFORMATION

Models A104 and U109.

MODEL A104 is a five valve, including rectifier superheterodyne receiver covering the short, medium and long wavebands. It operates from A.C. mains only.

MAINS SUPPLY - 200-250 volts, 50-100 cps.

CONSUMPTION. (T2 primary current) 258 ma. at 225 volts.

PILOT LAMPS. 6.5 volts, 300 ma. MES

VALVES. See circuit diagram. All valves are Mullard and have 88A bases.

Note:- The five valve heaters are series fed from T2 secondary.

WAVERANGES. SW-16.0 to 51 metres. MW - 185 to 570 metres. LW - 950 to 2150 metres.

INTERMEDIATE FREQUENCY. 460 Kc/s.

LOUD-SPEAKER IMPEDANCE. 3 ohms at 400 cps. On the rear centre panel, the upper pair of sockets are for the connection of an extension speaker. Immediately below these sockets is the screw type muting switch.

FIG.-UP. The lower pair of sockets on the rear centre panel are for the connection of a pick-up, the connections for which are completed when the W/C switch is set to 'GRAM'.

MODEL U109 is an AC/DC mains version of the A104

MAINS SUPPLY. 200 - 250 volts, A.C. or D.C.

CONSUMPTION. A.C. 243ma. (at 225 volts).
D.C. 165ma. (at 220 volts).

PILOT LAMPS 6.2 volts, 300 ma. MES

VALVES. See circuit diagram.

WAVERANGES. - I.F. - LS, IMPEDANCE, - PICK-UP. As for A104.

ALIGNMENT FOR BOTH MODELS.

POINTER SETTING. Close the gang and rotate tuning control fully clockwise, then adjust the pointer to the datum line terminating the lower frequency ends of all wavebands.

IF ALIGNMENT. Switch to MW, fully close gang and set V/C to maximum. Inject 460 Kc/s via 0.1 mfd condenser to control grid (pin 6) of UCH42, then adjust the IFT cores for maximum output in the following order:- 2nd IFT upper and lower then 1st IFT upper and lower. Inject 460 Kc/s to aerial socket, then adjust L1 (IF rej.) core for minimum output

CALIBRATION. Inject signals to A and E sockets.

Switch to MW. Tune to and inject 1300 Kc/s then adjust C18 and C5. Tune to and inject 800 Kc/s then adjust L12 screw core. Check calibration at 600 Kc/s. Repeat as necessary. Switch to LW. Tune to and inject 250 Kc/s then adjust C21 and C7. Check calibration at 150 Kc/s. Switch to SW. Tune to and inject 6.5 Mc/s then adjust L10 and L3 cores. Tune to and inject 15 Mc/s then adjust C14 and C4. Repeat as necessary.

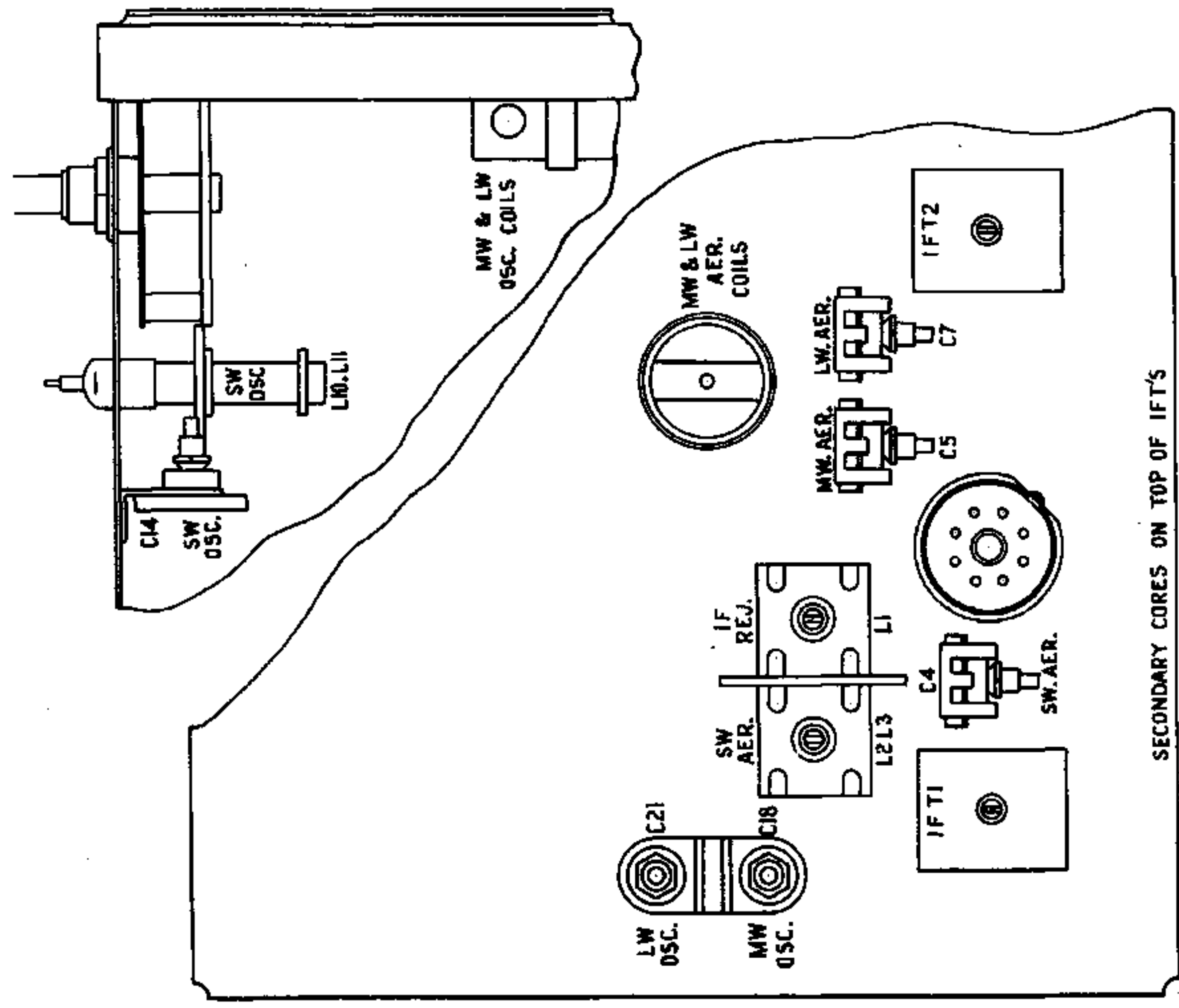

ADJUSTMENTS FOR ALIGNMENT AND CALIBRATION

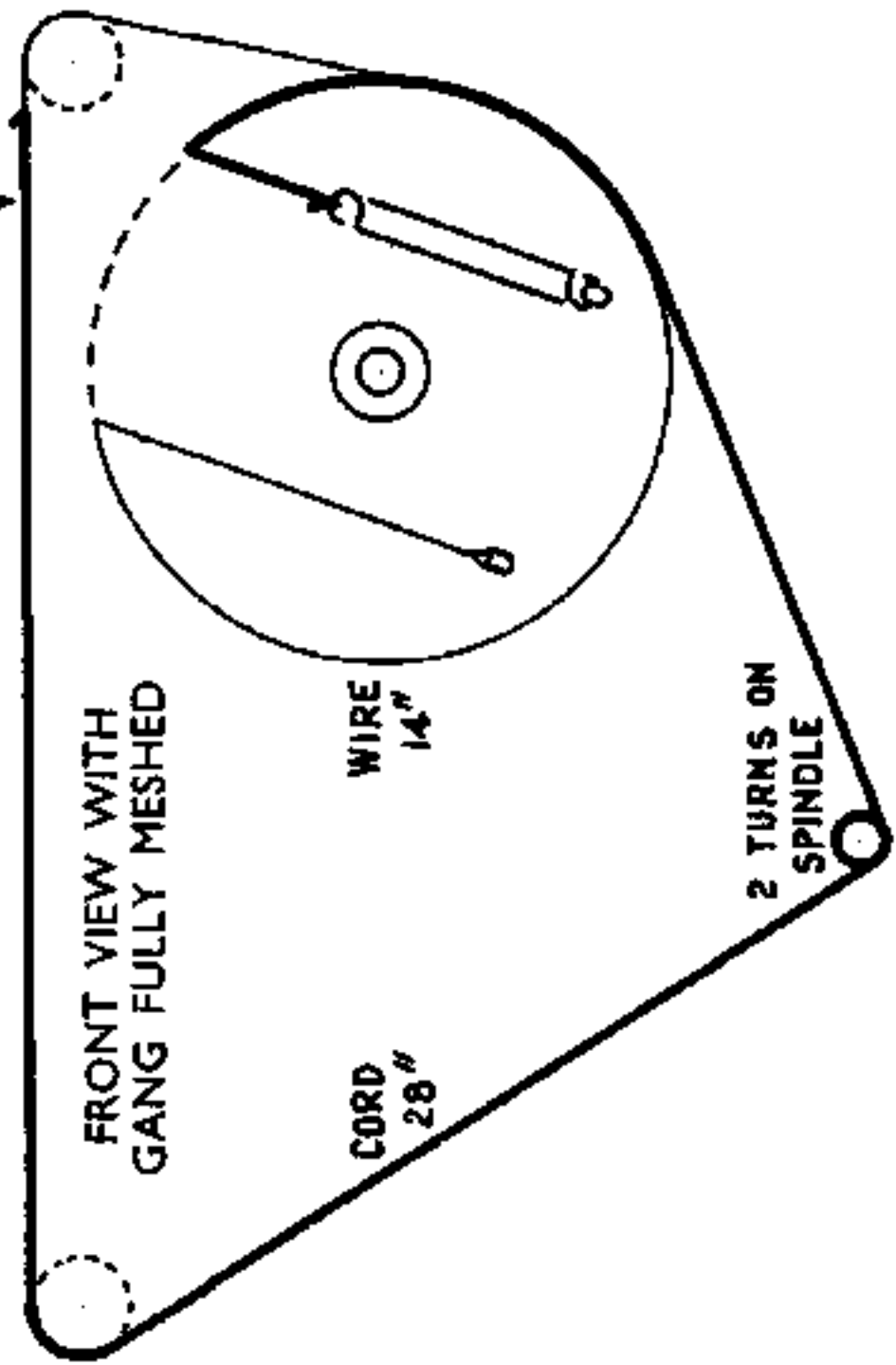

DRIVE CORD/WIRE DETAILS