

'TRADER' SERVICE SHEETS

RECEIVER SERIES (NUMBER TWENTY-TWO)

MODEL 435B in the Cossor 1934-5 range is a battery-operated table console receiver employing a straight 4-valve circuit which consists of a single variable-mu tetrode H.F. amplifier, an H.F. pentode grid leak detector, a small power triode "driver," and a Class B output stage. There are two tuned circuits, and a notable point is that the M.W. sections of the coils are of the iron-cored type.

CIRCUIT DESCRIPTION

Aerial input by way of series condenser **C1** to L.W. coupling coil **L1** and M.W. coupling condenser **C2**, the latter being switched in by **S1**. Single-tuned input circuit **L2, L3, C14** to variable-mu tetrode H.F. amplifier (**V1**, Cossor metallised **220 VS**). Gain controlled by potentiometer **R2** which varies G.B. applied. Tuned-secondary transformer coupling to H.F. pentode detector (**V2**, Cossor metallised **210 SPT**) working on grid leak system. Primary **L4, L5**; secondary **L6, L7** tuned by **C16**. Reaction applied from detector anode by coils **L8, L9** and controlled by variable condenser **C18**. Provision for connection of gramophone pick-up in low-potential end of **V2** grid circuit. G.B. obtained from potential divider **R4, R5** which, in conjunction with **R2**, also forms G.B. battery load.

Resistance-capacity fed auto-transformer coupling by **T1** to driver valve (**V3**, Cossor **215P**), which is coupled to Class B output stage (**V4**, Cossor **220B**) by a special transformer **T2**. Condensers **C11** in grid circuit, and **C12, C13** in plate circuit prevent parasitic oscillations. **C12** and **C13** also give a degree of tone compensation.

DISMANTLING THE SET

Removing Chassis.—Remove the knobs, which are held by set screws, with the exception of the trimmer knob, concentric with the main tuner, this being held by a central slotted nut. When replacing the knobs, see that the set screws engage in the slots in the shafts. The left-hand small knob is marked "Increase," the central one, below the tuner, "Volume," and that on the right, "Off, G. L. S."

Remove back of cabinet (4 screws and washers). Slide out the H.T. battery platform and the vertical piece of wood on which one side of the platform rests.

Unsolder the three leads going to tags on the speaker input transformer. These leads all have blue rubber coverings in the latest models, but the centre one is marked by red paint. It is best to tie a knot in this one in case the paint flakes off. Some earlier models had a yellow

COSSOR 435B BATTERY RECEIVER

central lead. When replacing these leads, note that only the two outer tags and the central one are in use.

Undo the four screws and washers from underside of base of cabinet. The chassis can then be withdrawn.

Removing Speaker.—If this should be necessary, it is best to remove speaker complete with its sub-baffle. The latter is held to the cabinet by six wood screws.

COMPONENTS AND VALUES

Resistances		Values (ohms)
R1	V1 cont. grid decoupling ..	2,000,000
R2	Volume control ..	50,000
R3	Pick-up series resistance ..	100,000
R4	V2 G.B. pot. divider ..	50,000
R5		100,000
R6	V2 grid resistances ..	3,000,000
R7		2,000,000
R8	V2 S.G. H.T. feed ..	500,000
R9	V2 anode decoupling ..	50,000
R10	V2 anode resistance ..	50,000
R11	V3 grid H.F. stopper..	100,000

Condensers		Values (μF)
C1	Aerial series condenser ..	0.0005
C2	M.W. coupling ..	0.000015
C3	V1 cont. grid decoupling ..	0.1
C4	V1 S.G. by-pass ..	0.1
C5	V2 grid condenser ..	0.0001
C6	V2 S.G. by-pass ..	0.1
C7	V2 anode H.F. by-pass ..	0.0002
C8	V2 anode decoupling ..	0.1
C9	L.F. coupling to T1 ..	0.1
C10	H.T. reservoir ..	2.0
C11	T2 sec. shunt ..	0.0005
C12	Tone compensators ..	0.1
C13		0.1
C14	Aerial tuning ..	0.0005
C15	Aerial trimmer ..	—
C16	H.F. trans. sec. tuning ..	0.0005
C17	H.F. trans. sec. trimmer, pre-set ..	—
C18	Reaction condenser ..	0.00035

Other Components		Values (ohms)	
L1	Aerial coupling coil ..	9.3	
L2	Aerial tuning coils ..	1.5	
L3		13.0	
L4		1.0	
L5	H.F. transformer primary ..	9.5	
L6	H.F. transformer secondary ..	1.5	
L7		13.0	
L8	Reaction coils ..	0.4	
L9		3.3	
L10	Speaker speech coil ..	1.25	
T1	Auto-transformer, total winding ..	4,500	
T2	Driver trans. ..	500	
T3	Speaker input trans. ..	Pri. total ..	95
		Sec. total ..	500
S1-S4	Waveband switches, ganged ..	—	
S5	Gram. pick-up switch ..	—	
S6	Filament switch ..	—	

VALVE ANALYSIS

All values given in the table below were obtained from an average receiver with a new 120 V H.T. battery in use, and the correct H.T. and G.B. voltages applied. No aerial or earth was connected and the volume control was at maximum.

Valve	Anode Volts	Anode Current (mA)	Screen Volts	Screen Current (mA)
V1 220 VS	120	2.7	60	0.4
V2 210 SPT	45*	0.7	20*	0.2
V3 215 P	119	2.5	—	—
V4 220 B	119†	1.3†	—	—

* Depends largely on meter used. † Each section.

Voltages were measured on the 1,200 V scale of an Avometer with the chassis as negative, and the currents of **V1** and **V2** were taken with a milliammeter inserted in the low H.F. potential ends

(Continued overleaf)

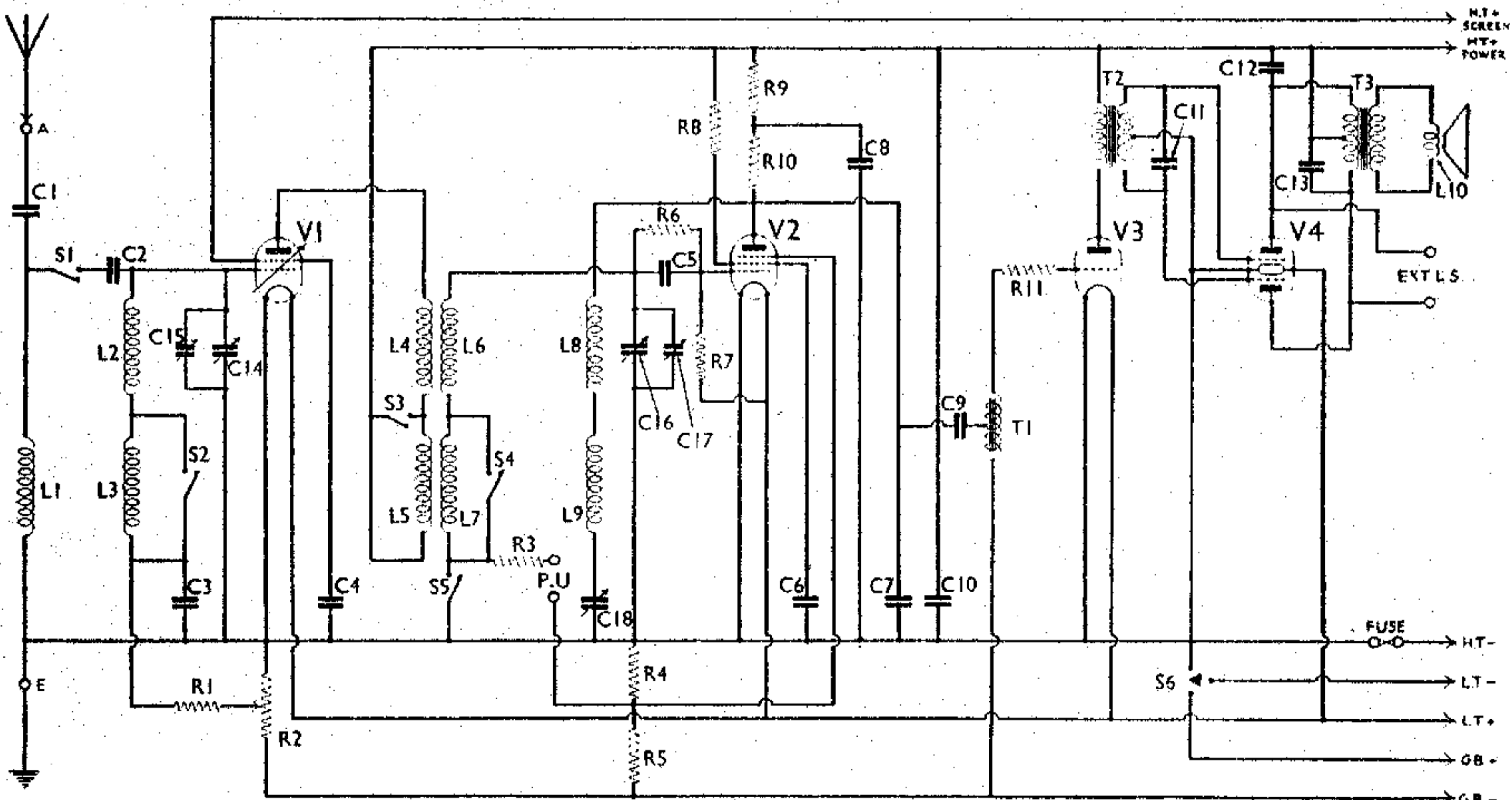

Circuit diagram of the Cossor Model 435B battery receiver.

COSSOR MODEL 435B
(cont'd)

of the circuits. The anode and screen voltages obtained from V2 depend largely upon the meter used, since owing to the large resistances in the associated circuits the voltages are considerably affected by the current consumption of the meter.

GENERAL NOTES

Switches.—All the switches are mounted in a single unit which is clearly shown at the right-hand side of the under-chassis view. All but S6 have knife-like blades which rub against the fixed spring contacts, and the switches are therefore self-cleaning. S6, the 3-point battery switch, has a cylindrical type of moving contact, the three fixed contacts being shorted in all but the "off" position.

In the event of cleaning or adjustment of the contacts being necessary, the whole moving assembly can be easily removed by depressing the ends of the flat spring clip behind the front of the chassis, and removing this clip. The assembly can then be lifted up through the slot in the front of the chassis, and at the same time pulled out of the hole in the back of the chassis, when it is rendered free. Note that the spring clip is located and prevented from sliding out by a small hole and a peg on one of its supports. The table shows the switch positions.

Switch	M.W.	L.W.	Gram.
S1	Closed	Open	Open
S2	Closed	Open	Open
S3	Closed	Open	Closed
S4	Closed	Open	Open
S5	Closed	Closed	Open
S6*	Closed	Closed	Closed

* Open in the "off" position.

Coils.—There are two coil units, screened by cans having bayonet fittings at their bases. To remove the cans, first

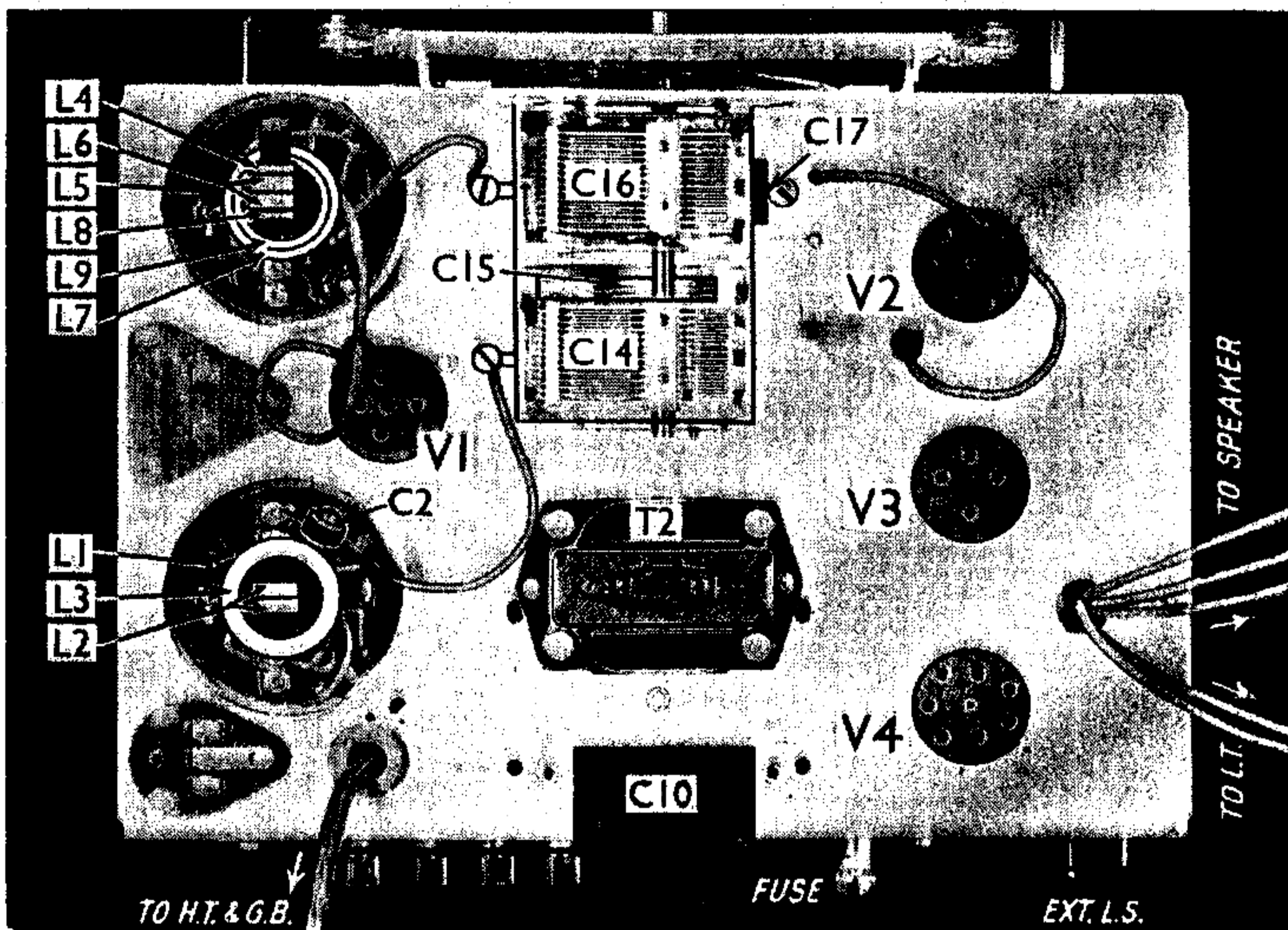

Plan view of the chassis with the coil and condenser screens removed. L1 and L5 are below L3 and L7 respectively.

detach the rubber-covered leads from the variable condenser unit and pull them through the rubber bushes in the sides of the screens. The front can also has a lead to the anode of V1 coming through the top. The cans are removed by breaking the paper seals and twisting.

The medium wave coupling, tuning and reaction coils are on small horizontal formers at the top of the units, provided with square section iron cores. The L.W. coils are on the vertical cylindrical formers. The lowest coil on each cylindrical former, being smaller in diameter than the one above, is not clearly seen in our plan view of the chassis. The two bottom coils are the coupling coils L1 and L5.

The iron cores of the M.W. coils are wedged in position, and care should be

taken not to disturb them.

Tuning Condenser Unit.—Should this need attention, the cover can be removed (as has been done in our plan view) by loosening the four screws holding it. In early models, removal of this cover was rather more difficult. The pre-set trimmer C17 is sealed with red wax. The variable trimmer C15 is part of the C14 assembly, and is operated by the knob concentric with the main tuner.

Battery Leads and Voltages.—The two L.T. leads emerge from the top of the chassis with the three speaker leads. In our sample L.T.+ is blue in colour, whilst L.T.— is a bluey-green. The latter is connected to S6 underneath the chassis.

The H.T. and G.B. leads emerge in the form of a braided cable. The colour coding is: H.T.—, black; H.T.+ marked "S.G. Screen," yellow; H.T.+ marked "Power," green; G.B.+ , red; G.B.—, blue.

The recommended voltages are: L.T., 2 V; H.T. "S.G. Screen," +60 V; H.T. "Power," +120 V; G.B.—, —9 V.

External Speaker.—The sockets provided at the rear of the chassis are connected from plate to plate of V4, and the external speaker should preferably have a Class B input transformer.

Fuse.—The fuse bulb is rated at 3.5 V, 0.15 A, and is of the M.E.S. type.

C5, R6.—The grid condenser C5 and its parallel resistance R6 are in one casing, and in external appearance resemble an ordinary tubular condenser.

Condensers C12, C13.—These are not seen in our chassis views, as they are mounted on the speaker input transformer T3, behind the terminal panel.

Chassis Modifications.—This sheet deals with the latest chassis, and some earlier models had a different circuit and a different under-chassis layout. The main circuit difference is that there was resistance coupling between V2 and V3 instead of the auto-transformer T1 in the latest models.

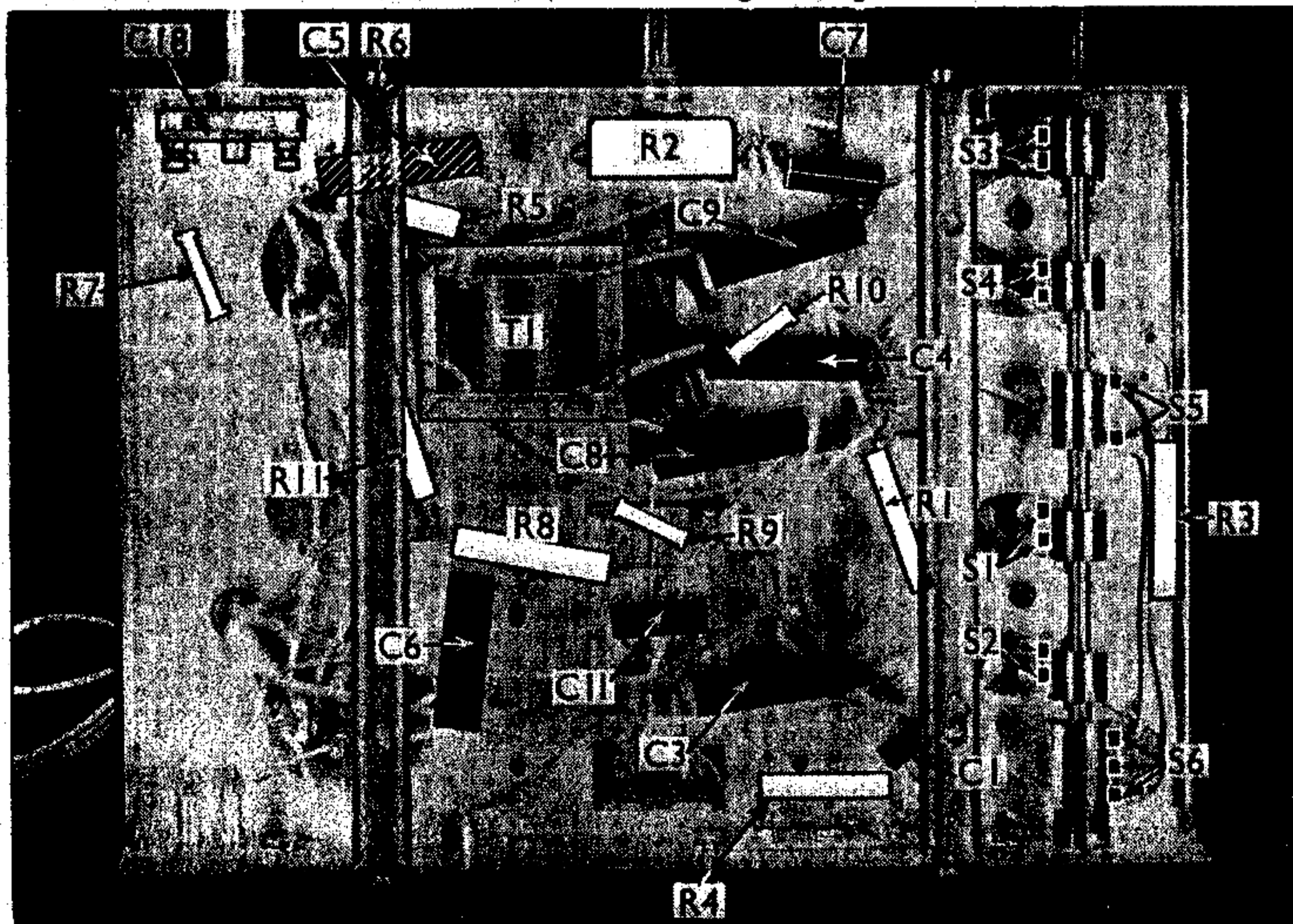

The under-chassis view, showing the switch assembly.