

# COSSOR SERVICE HINTS

and INSTRUCTIONS for

## MODEL 374

(Series A)

# A.C. MAINS SUPER-HET RECEIVER

Ned. Ver. v. Historie v/d Radio

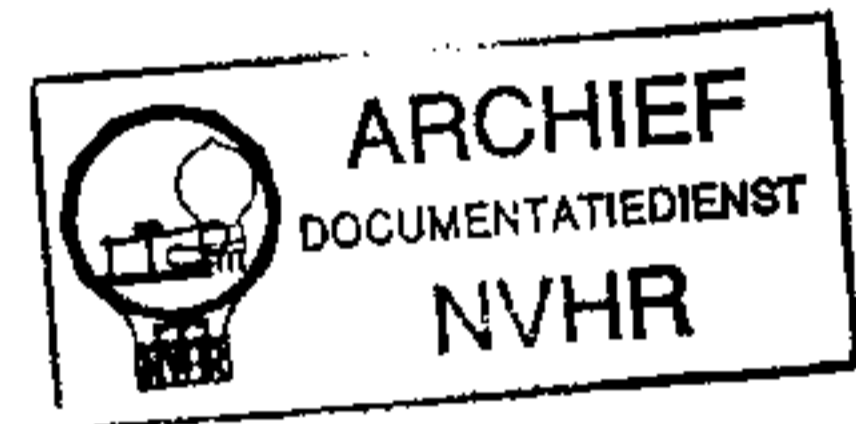
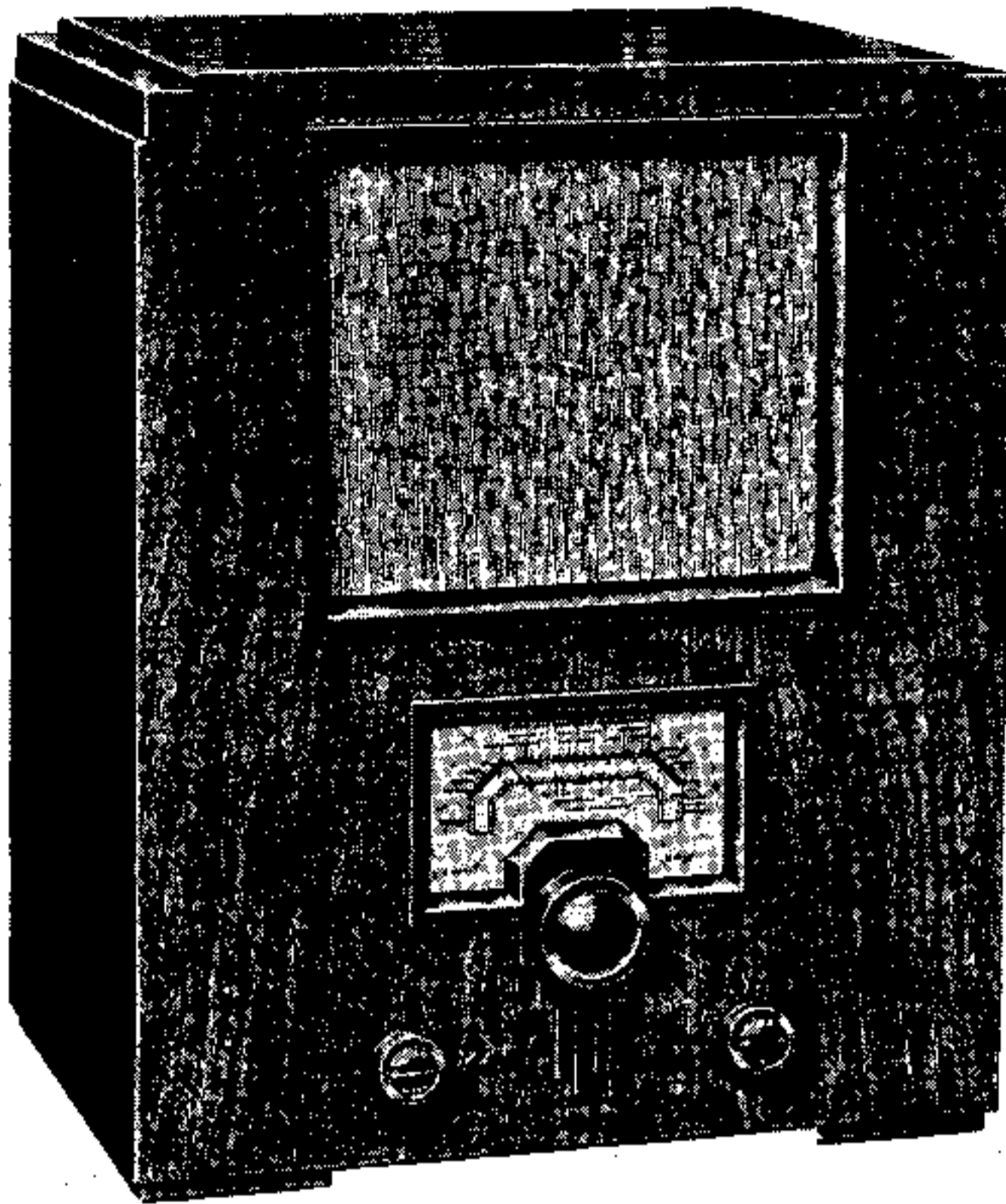

## MODEL 374

(Series A)

200/250 Volts. A.C.  
50/100 cycles.

### SPECIFICATION

Cossor Model 374 (Series A) is an A.C. mains operated super-heterodyne receiver employing the following five Cossor valves: 41 M.P.G. frequency changer, M.V.S. Pen. I.F. amplifier, D.D.4. A.V.C. rectifier and second detector, 42 M.P.Pen. output and 442 B.U. rectifier. Detachable illuminated tuning scale calibrated in wavelengths and station names. Tuning, volume and combined wave change and on/off controls are provided. 8 in. energised moving coil loudspeaker. Provision for extension loudspeaker and pick-up.

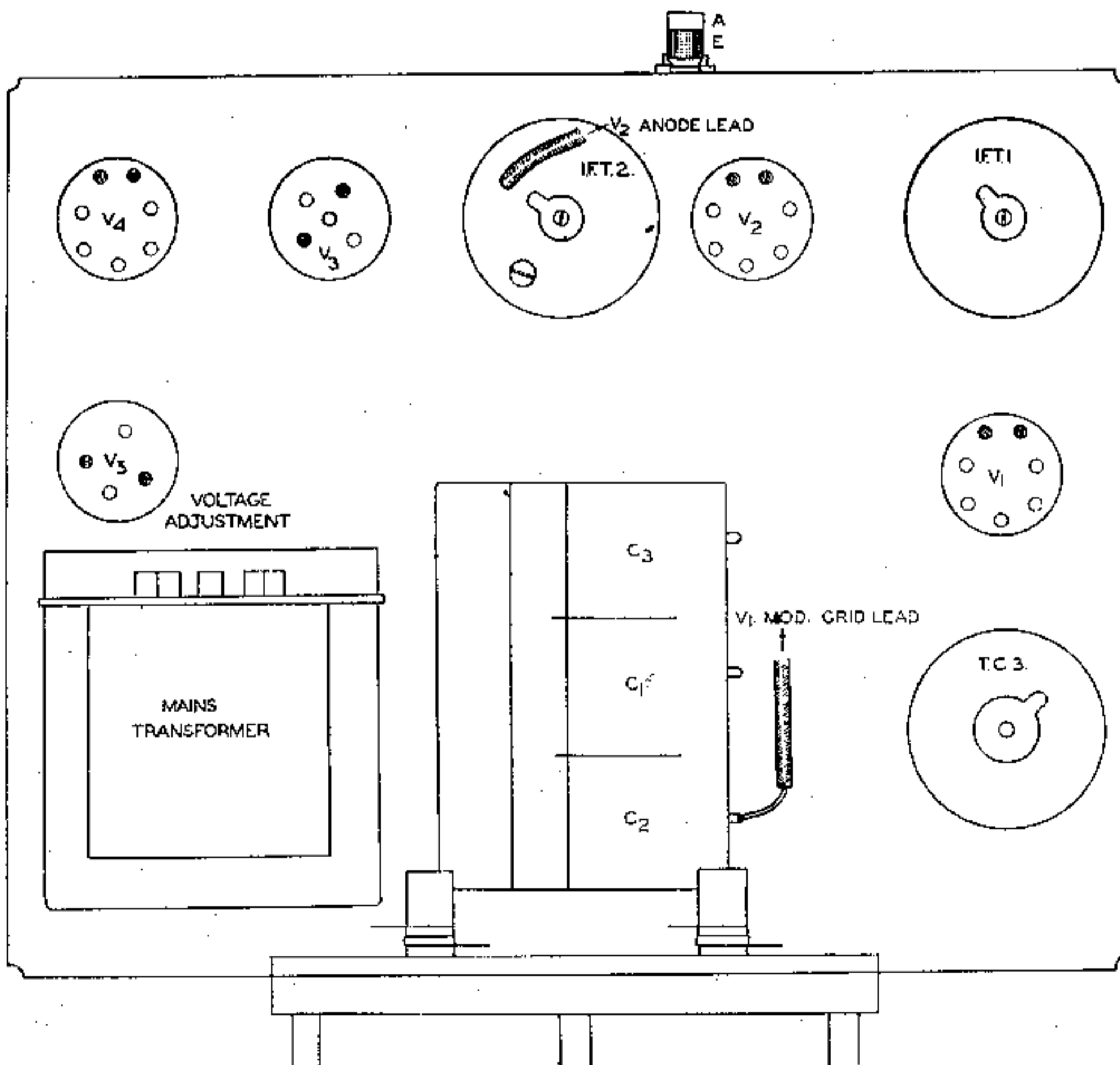

PLAN VIEW OF TOP OF CHASSIS

# THEORETICAL CIRCUIT DIAGRAM OF MODEL 374 (Series A)

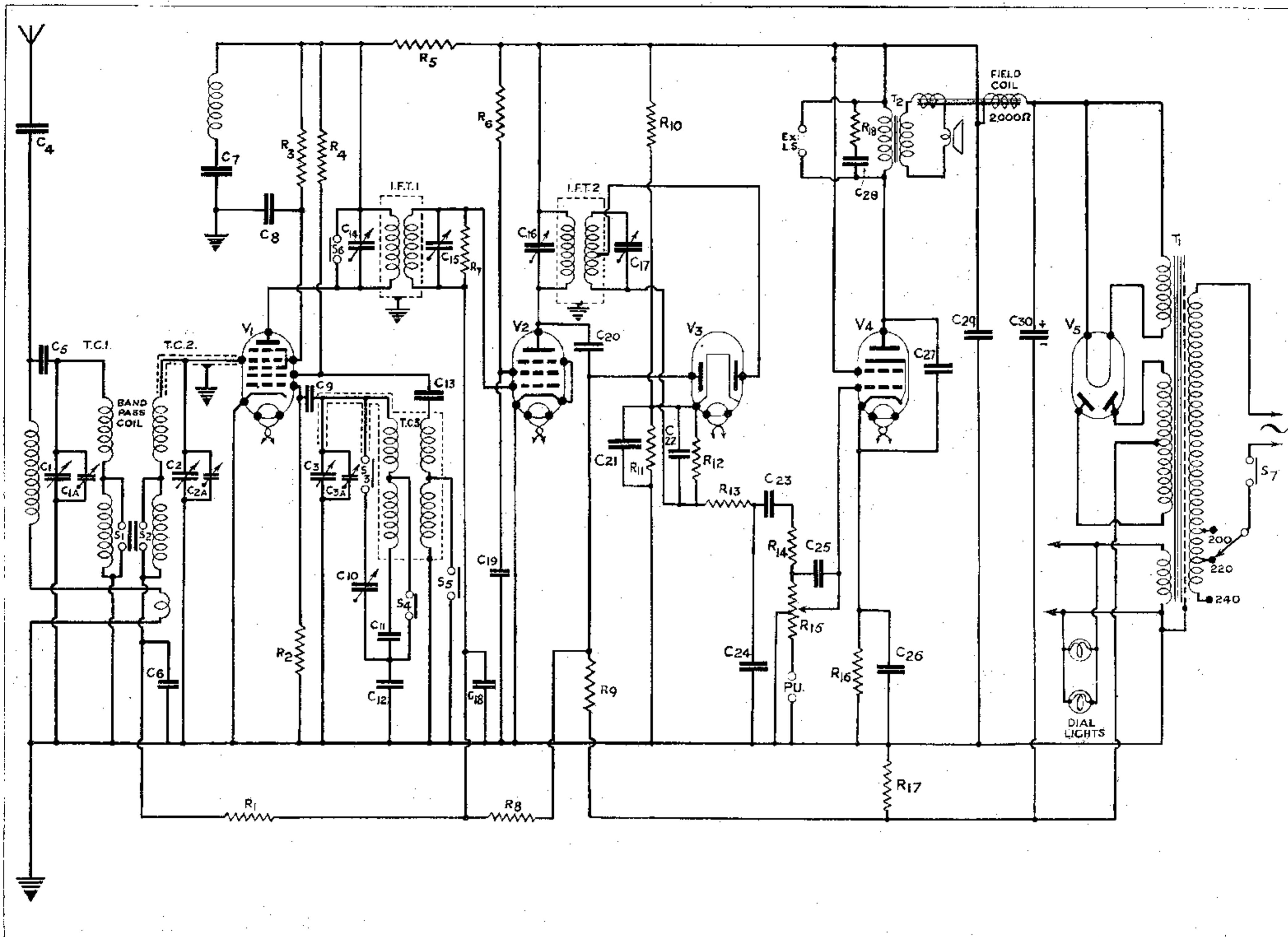

## COMPONENT VALUES

### CONDENSERS.

- C 1 } 3 gang Condenser.
- C 2 } 3 gang Condenser.
- C 3 } 3 gang Condenser.
- C 4—·0003 mfd. fixed (Mica).
- C 5—25 m.m.f. fixed (Mica).
- C 6—·1 mfd. fixed (Tub.).
- C 7—·1 mfd. fixed (Tub.).
- C 8—·1 mfd. fixed (Tub.).
- C 9—·00025 mfd. fixed (Mica).
- C10—30 m.m.f. L.W. Trimmer.
- \*C11—1,020 m.m.f. fixed (Mica).
- \*C12—2,080 m.m.f. fixed (Mica).
- C13—·002 mfd. fixed (Mica).
- C14 } 220 m.m.f.
- C15 } I.F.T.1. Trimmers.
- C16 } 220 m.m.f.
- C17 } I.F.T.2. Trimmers.
- C18—·1 mfd. fixed (Tub.).
- C19—·1 mfd. fixed (Tub.).
- C20—·0001 mfd. fixed (Mica).
- C21—·005 mfd. fixed (Tub.).
- C22—·0002 mfd. fixed (Mica).
- C23—·01 mfd. fixed (Tub.).
- C24—·0001 mfd. fixed (Mica).
- C25—·0005 mfd. fixed (Mica).
- C26—50 mfd. fixed (Electrolytic)
- C27—·002 mfd. fixed (Mica).
- C28—·01 mfd. fixed (Tub.).
- C29—8 mfd. fixed (Electrolytic).
- C30—8 mfd. fixed (Electrolytic).

\* Consists of two condensers in parallel.

### RESISTANCES.

- R 1—·5 Megohm.
  - R 2—50,000 ohms.
  - R 3—50,000 ohms.
  - R 4—50,000 ohms.
  - R 5—10,000 ohms.
  - R 6—·1 Megohm.
  - R 7—·5 Megohm.
  - R 8—2 Megohms.
  - R 9—2 Megohms.
  - R10—·1 Megohm.
  - R11—40,000 ohms.
  - R12—50,000 ohms.
  - R13—25,000 ohms.
  - R14—25,000 ohms.
  - R15—·25 + ·25 Megohm.
  - R16—130 ohms.
  - R17—25 ohms.
  - R18—15,000 ohms.
- D.C. resistances of L.F. components.  
 L.S. Field Coil—2,000 ohms.  
 T1—Mains Transformer.  
 Primary winding—20 ohms.  
 Secondary H.T. winding—406 ohms.  
 Secondary heater winding—·06 ohm.  
 Secondary rec. heater winding—·11 ohm.  
 T2—Output Transformer.  
 Primary Winding—750 ohms.  
 Secondary winding—·2 ohm.

# GENERAL INFORMATION

## 1. METERS REQUIRED FOR TESTING.

- 1—Voltmeter of the 1,000 ohms. per volt type (A.C. and D.C.), reading 0—30 v., 0—300 v. and 0—600 v. (approx.).
- 1—Milliammeter reading 0—10 m/a and 0—100 m/a (approx.).
- 1—Ohm-meter reading 0—1,000 ohms and 0—1 Megohm. (approx.).
- 1—Low range output meter.

## 2. VALVES.

- V1—Type 41 M.P.G. Met. 7 pin. base, Top cap, modulator grid.
- V2—Type M.V.S. Pen. Met. 7 pin base, Top cap, anode.
- V3—Type D.D.4. Clear, 5 pin base.
- V4—Type 42 M.P. Pen. Clear, 7 pin base.
- V5—Type 442 B.U., 4 pin base.

## 3. DIAL LIGHTS.

These are 6.5 v. .3A. M.E.S. type bulbs (Cossor Cat. No. 365). If a replacement is necessary note that the holder may be slipped off its bracket.

## 4. SWITCH CONTACTS.

Switch Position	Closed Contacts
S.W.	S1, S2, S4, S5 and S7
L.W.	S3 and S7
Gram.	S6 and S7

## 5. EXTENSION LOUDSPEAKER.

A permanent magnet loudspeaker fitted with an output transformer having an impedance of eight thousand to ten thousand ohms. should be used. It is advisable to fit a 4 mfd. condenser near the set in series with each lead. Cossor loudspeaker Model 595 is recommended.

## 6. MAINS TRANSFORMER CONNECTIONS.

The mains transformer solder tags are clearly indicated on the underside view of chassis and the connections to each tag are as follows:

Primary tag—to mains lead.

H.T. tags—to anode pins of 442 B.U. valve holder.

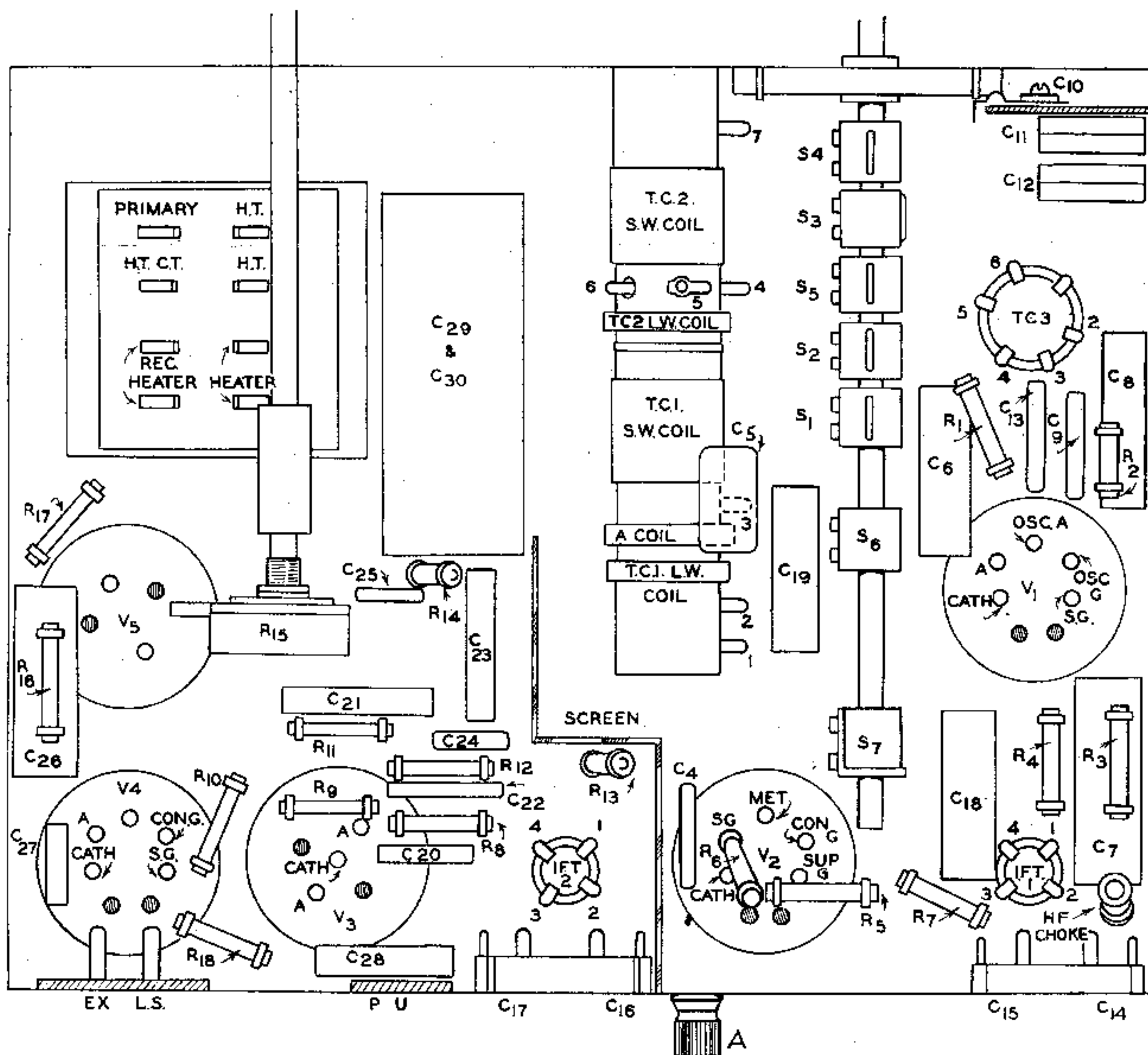

UNDERSIDE VIEW OF CHASSIS

# TUNING COIL CIRCUITS

NOTE.—The bottoms of coils are drawn with heavy lines and are shown as seen from the underside view of chassis. All wiring is shown in fine lines.

When replacing a coil make sure the pointer on the top of the coil can is in the same position as that shown on the top view of chassis.

## T.C.1. & T.C.2.

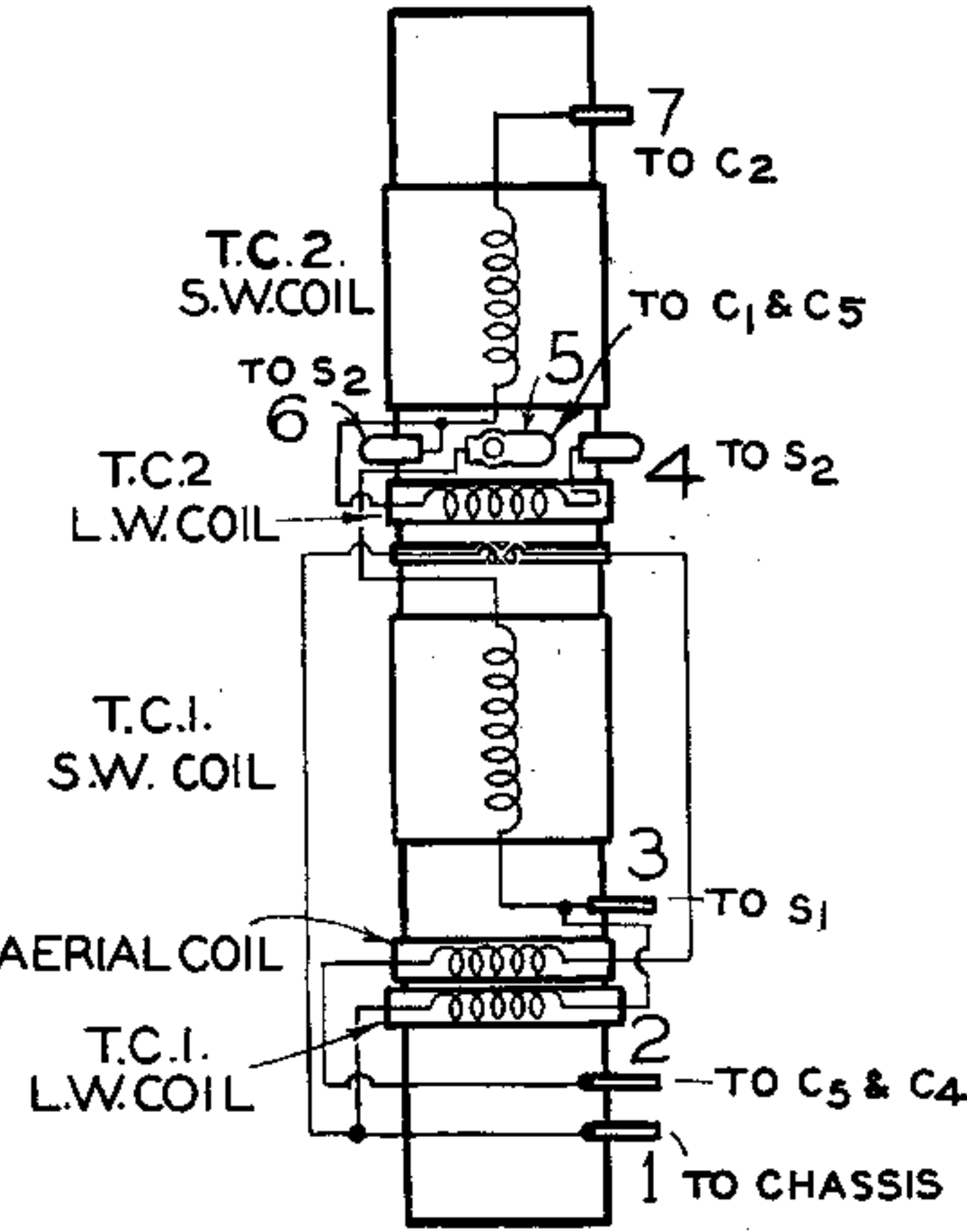

## T.C.3.

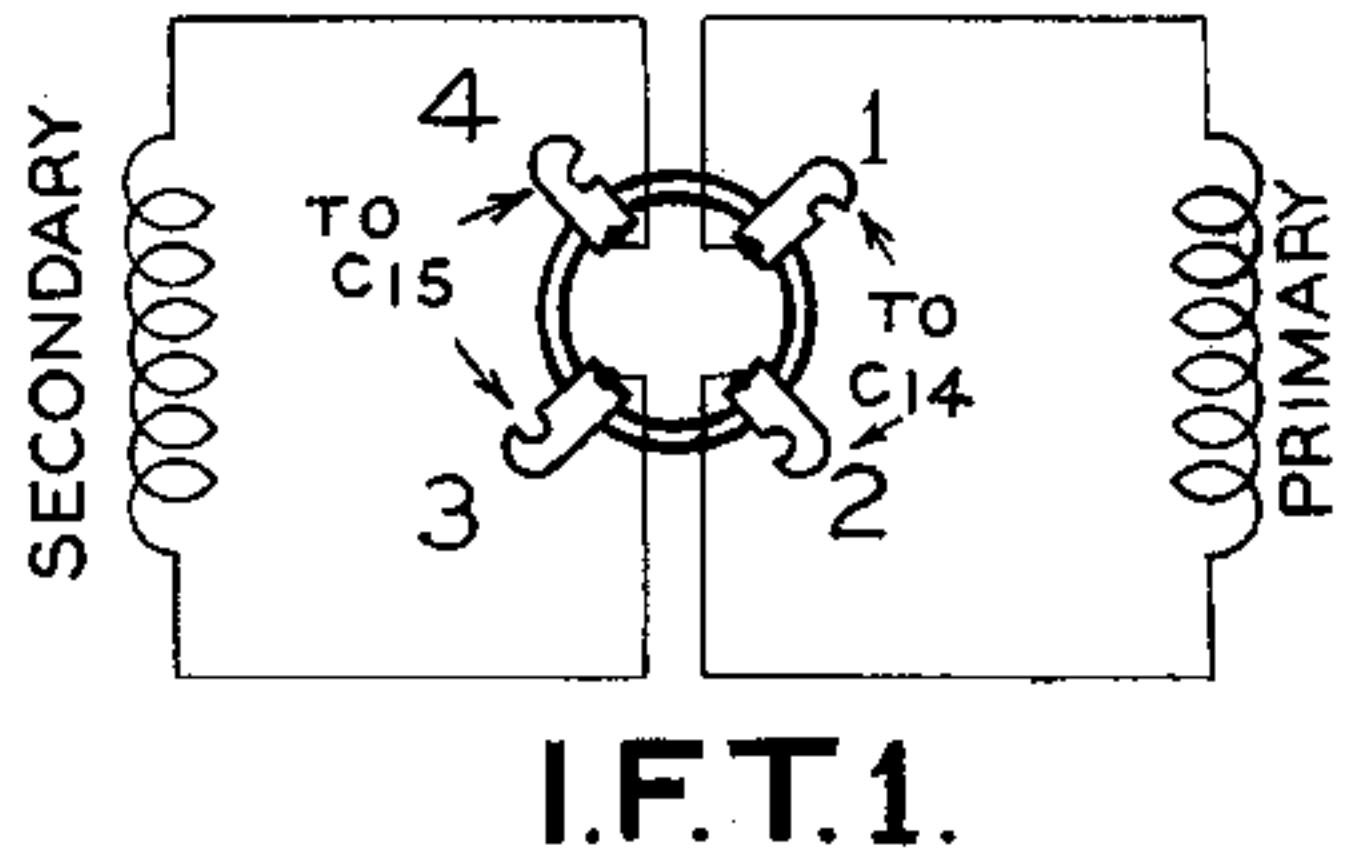
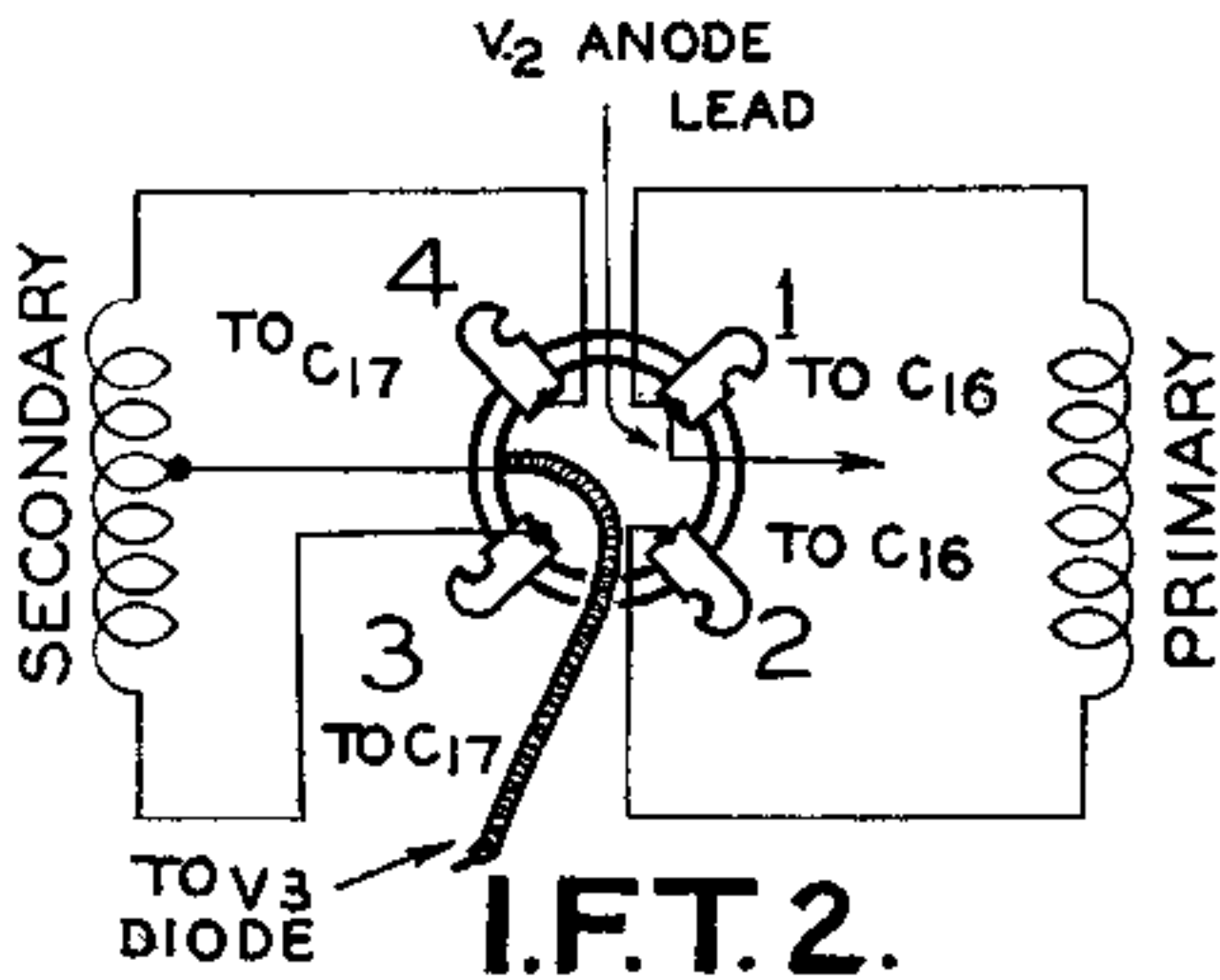
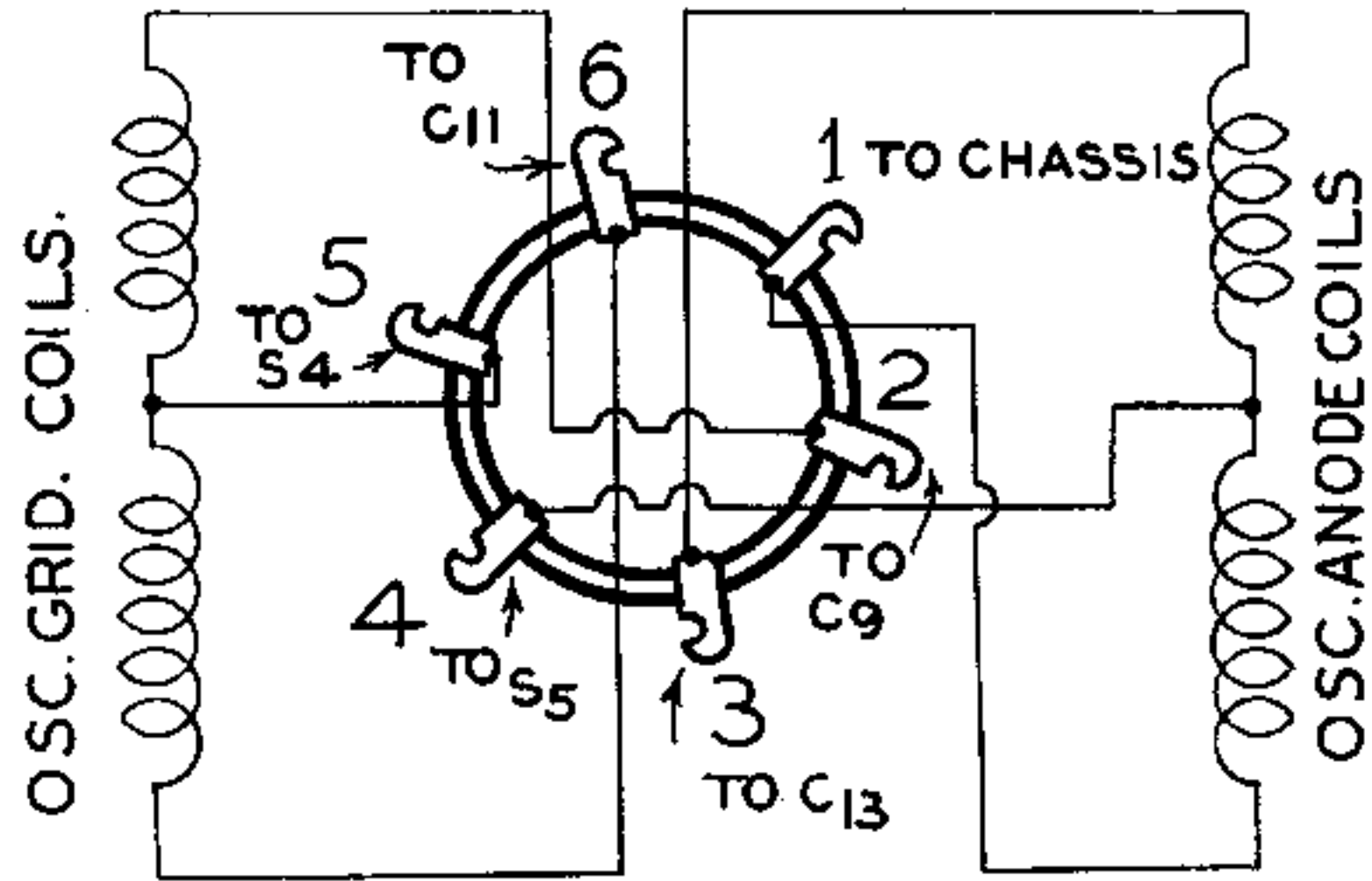

H.T., C.T. tag—to R17, negative lead from C30 and lead from R9.  
 Rec. Heater tags—to heater pins of 442 B.U. valve holder.  
 Heater tags—to heater pins of D.D.4 valve holder.

## 7. TO REMOVE THE CHASSIS.

Remove :

1. The back and three knobs. Note : There are two grub screws in the large knob.
2. Two small screws holding top of reflector to cabinet front and one pin holding L.S. leads to cabinet side.
3. Four main fixing bolts.

Note : A false bottom is fitted to this model.

## 8. TO REMOVE THE LOUDSPEAKER.

Disconnect the three leads, loosen the four large nuts and turn the L.S. clamps through 90° while holding the loudspeaker, which may then be lifted out.

## 9. VOLTAGE AND CURRENT READINGS.

The readings given below were obtained with meters as specified in paragraph 1. No aerial was connected and the receiver was tuned to a wavelength of 320 metres, where no signals were obtained.

The chassis was taken as negative for all voltage readings.

Valve	Anode Volts	Anode Current	Screen Volts	Screen Current	Osc. Anode Volts	Osc. Anode Current
<b>V1</b> <b>41 M.P.G.</b> Switch in S.W. position Heater Current 1 amp.	190 v.	1 m/a.	75 v.	2.2 m/a.	90 v.	1.9 m/a.
<b>V2</b> <b>M.V.S. Pen.</b> Heater Current 1 amp.	245 v.	5.6 m/a.	90 v.	1.4 m/a.	—	—
<b>V3 D.D.4.</b> Heater Current 0.75 amp.	Cathode to chassis 70 v.				—	—
<b>V4</b> <b>42 M.P. Pen</b> Heater Current 2 amp.	220 v.	30 m/a.	245 v.	7 m/a.	—	—
<b>V5 442 B.U.</b> Heater Current 2.5 amps.	330 v. each Anode		Max. unsmoothed H.T. 360 v. Max. smoothed H.T. 245 v.			

Consumption : 55 watts.  
 Supply : 240 v. A.C.

# FAULTS AND THEIR PROBABLE CAUSES

Always check the following points first :

1. That the supply point is live.
2. That the mains lead shows continuity.
3. That the aerial and earth leads are not shorting.
4. That all valves are firmly in their holders with top cap leads connected.
5. That the voltage adjusting strip on the mains transformer is correctly adjusted.

## 10. HEATER VOLTAGE NOT NORMAL.

Test all valve heaters for correct current consumption. Verify that mains voltage adjustment is correct.

## 11. VOLTAGES TO V1 NOT NORMAL.

**ANODE.** Test : I.F.T.1. primary for continuity.  
**SCREEN.** Test : R3 for continuity.  
 C8 for breakdown.  
**OSC. ANODE.** Test : R4 for continuity.  
 C13 for breakdown.  
**GRID BIAS.** Test : T.C.2, R1, R8, R9 and R17 for continuity.  
 C2, C2A, C6, C18 and all associated wiring for short to chassis.  
 Also verify that V4 is passing its correct current.

**NOTE.**—Voltage readings will be incorrect if the valve is not oscillating. To check this, short tag 3 of the osc. coil to chassis when a rise of anode current should be noted.

## 12. VOLTAGES TO V2 NOT NORMAL.

**ANODE.** Test : I.F.T.2 primary for continuity.  
 C20 for breakdown.  
**SCREEN.** Test : R6 for continuity.  
 C19 for breakdown.  
**GRID BIAS.** Test : I.F.T.1 secondary and R7 for continuity, also test for bias voltage as given in paragraph 11.

## 13. VOLTAGES TO V3 NOT NORMAL.

**CATHODE.** Test : R10 and R11 for continuity.  
 C21, C23 and C24 for breakdown.

It will be noted that the cathode voltage and therefore delay voltage is higher than usual, being some 70 volts above chassis. This is necessary because of the low value of the signal diode load resistance R12 required to feed the output valve.

## 14. VOLTAGES TO V4 NOT NORMAL.

**ANODE.** Test : T2 primary for continuity.  
 C27 for breakdown.  
**GRID BIAS.** Test : R16 for continuity.  
 C26 for breakdown.

## 15. H.T. SUPPLY VOLTAGE NOT NORMAL.

Test L.S. field coil, H.T. winding, V5 valve holder and R17 for continuity. C30, C29 and C27 for breakdown.

## 16. RECEPTION NOISY.

External interference is the most likely cause of this trouble. Trams, neon signs, loose wires in house switches, poor aerial insulation, loose mains plugs, etc., may all cause noises. A rough test is to disconnect the aerial and earth wires. If the noise stops the receiver is probably not the cause and the external causes mentioned above should be investigated. If the noise continues make sure the valves are up to standard, check all wiring for dry joints and intermittent short to chassis and valve holders and switches for weak contacts.

## 17. REGANGING.

Intermediate frequency—128 K.C.s.  
 S.W. Test frequency —1,400 K.C.s (214.3 metres).  
 L.W. Test frequency —300 K.C.s (1000 metres).

Do not attempt any adjustments to the ganging unless an accurately calibrated modulated test oscillator is available. Also do not make any adjustments to the ganging until every other possible cause of the trouble has been investigated.

If adjustments are essential, disconnect the aerial, short tag 3 of the oscillator coil to chassis to stop V1 oscillating, unsolder the wire from the A.V.C. diode pin of V3 valve holder, connect a low range output meter to the Ex. L.S. sockets and turn the volume control full on. Before removing the wax from the I.F. trimmers try re-ganging the H.F. circuits as given in the latter part of this paragraph.

### ALIGNING I.F. TRANSFORMERS.

The I.F. frequency will be very nearly correct and it will therefore only be necessary to connect the test oscillator, set at 128 K.C.s., direct to the 41 M.P.G. modulator grid through a .1 mfd. condenser and adjust each I.F. trimmer for maximum deflection of the output meter needle. Adjust C17 first and work back to C14. Use a small oscillator output just sufficient to give a readily readable deflection of the meter needle.

### GANGING H.F. CIRCUITS.

#### SHORT WAVES.

Connect the test oscillator, set at 1,400 K.C.s., to the A. and E. leads through a dummy aerial or .0002 mfd. condenser, remove the connection referred to above from tag 3 of the oscillator coil to chassis, and turn the wave change switch to the short wave position.

Adjust the receiver gang condenser to 214 metres, first making sure that the indicator stops exactly at the 200 metre mark when the tuning knob is turned fully anti-clockwise.

Use a small test oscillator output and adjust C3A, the gang condenser trimmer nearest the back of the receiver, for maximum output. Next adjust C2A and then E1A for resonance.

#### LONG WAVES.

Turn the wave change switch to the L.W. position and adjust the test oscillator to 300 K.C.s. Set the receiver gang condenser to 1,000 metres and adjust C10, accessible through a hole in the front right hand side of the chassis, for maximum deflection of the output meter needle.

Finally resolder the wire to V3 valve holder, seal the trimmer and disconnect the output meter and oscillator.

IT IS ADVISABLE TO RETAIN A COMPLETE SET OF NEW OR TESTED "COSSOR" VALVES, AS IT IS VERY MUCH SIMPLER TO SERVICE A RECEIVER KNOWING THAT THE TEST VALVES ARE O.K.

WE WOULD MENTION THAT OUR GUARANTEE IS ONLY VALID IF "COSSOR" VALVES, AS SPECIFIED, ARE USED.

**Our distributing depots are at the service of those who, with the aid of this manual, are still unable to trace faults. To avoid difficulty, however, we would point out that under the terms of our guarantee, the SENDER is liable for costs involved by unnecessary returns.**

**It will save inconvenience and delay if a description of the fault or of its symptoms is enclosed with any instrument returned to us. This is particularly necessary with intermittent troubles, or those that only appear after a time interval.**

## A. C. COSSOR, LTD. HIGHBURY GROVE, LONDON, N.5

Tel. : Canonbury 1234 (20 lines).      Telegrams : Amplifiers, Phone, London.

### DISTRIBUTING & SERVICE DEPOTS

#### BIRMINGHAM

14/16 Carrs Lane (4).....Tel. Midland 5791/2/3  
Telegrams : Amplifiers, Birmingham.

#### LEEDS

17 Wellington Street (1).....Tel Leeds 21581/2  
Telegrams : Cossor, Leeds.

#### NEWCASTLE

3 St. Nicholas Buildings (1).....Tel. Newcastle 23154/5  
Telegrams : Amplifiers, Newcastle.

#### BRISTOL

14 Bath Street (1).....Tel. Bristol 20271/2  
Telegrams : Amplifiers, Bristol.

#### LIVERPOOL

42 Paradise Street (1).....Tel. Central 1877/8  
Telegrams : Amplifiers, Liverpool.

#### SHEFFIELD

3 Porter St., Moorhead (1).....Tel. Sheffield 23103/4  
Telegrams : Amplifiers, Sheffield.

#### GLASGOW

21 Waterloo Street (C2).....Tel. Central 4446/7  
Telegrams : Amplifiers, Glasgow.

#### MANCHESTER

6, 8 & 10 Cannon St. (3).....Tel. Blackfriars 9777/8/9  
Telegrams : Amplifiers, Manchester.

#### CARDIFF

4 Park Lane.....Tel. Cardiff 172/3  
Telegrams : Amplifiers, Cardiff.

#### DUBLIN

185 Pearse Street.....Tel. Dublin 44066

#### BELFAST

47 Queen St.....Tel. Belfast 26088  
Telegrams : Amplifiers, Belfast.