

COSSOR 338 BATTERY THREE

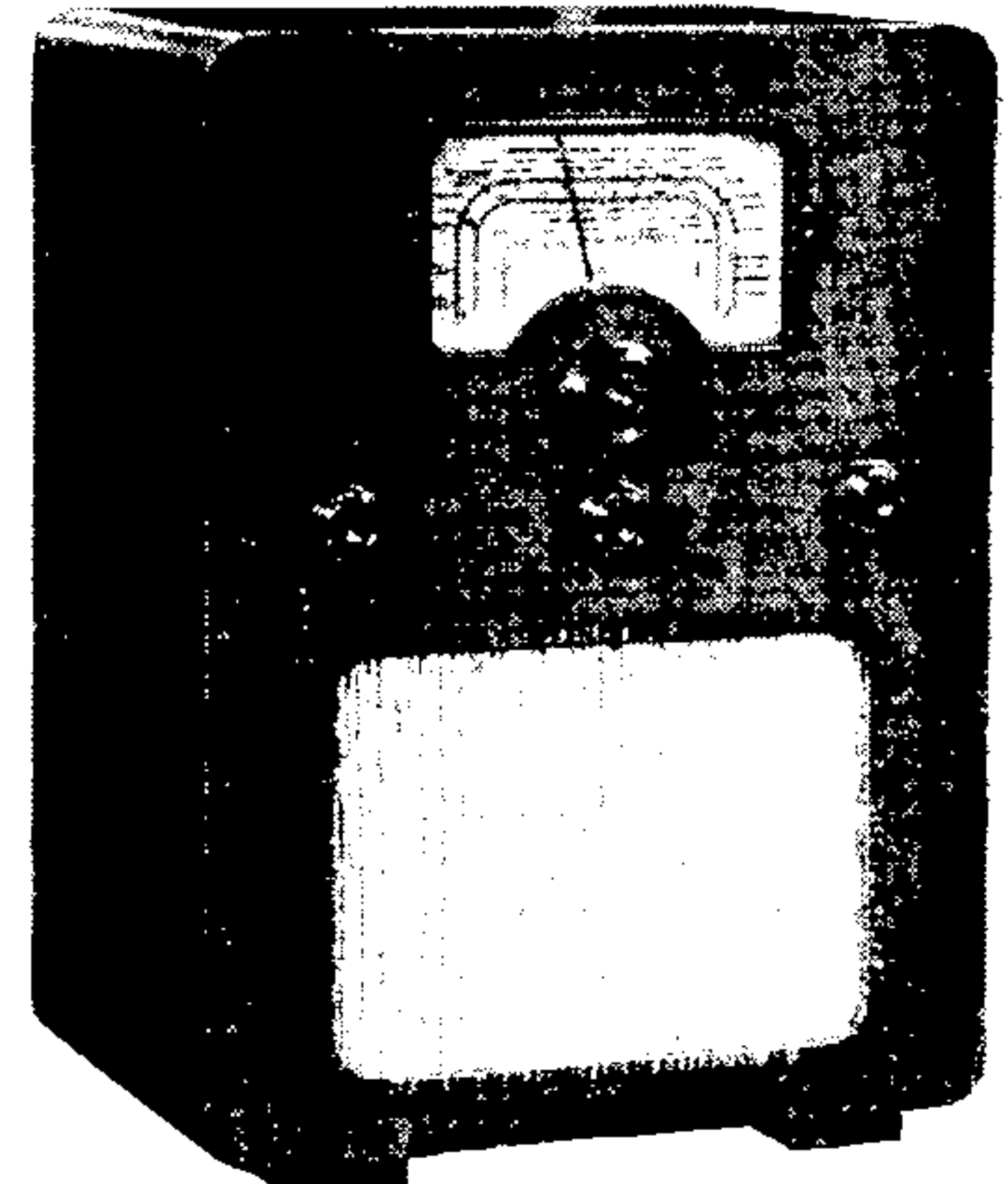

An unusual point about the model 338 is that it is a "straight" set on medium and long bands and a superhet on short waves.

CIRCUIT.—The aerial is coupled to the grid of V1 by a set of tuned secondary transformer coils. In the grid circuit is a manual volume control that varies the bias on the grid of the valve.

On the medium and long wave bands V1 operates as an H.F. amplifier and the grid of the oscillator triode is shorted to earth. On the short waves the short circuit is removed and V1 operates as a frequency changer.

V1 is tuned anode coupled to V2, an H.F. pentode, the demodulating stage of the receiver. Reaction is obtained in the usual manner from the anode with a coupling coil and controlled by a variable condenser.

The rectified signal then passes to V3, an output tetrode, via a coupling condenser and an auto transformer arrangement. In the anode circuit of V3 is connected the speaker matching transformer across the primary of which is connected a fixed condenser and resistance that modifies the tone.

Battery power is supplied by a Cossor 370 2-volt accumulator of 70 amp. hours capacity, a Cossor 120-volt H.T. battery of standard capacity, type 1120 or 2120, and a Cossor 9-volt G.B. battery type 933.

Special Notes.—A fuse is incorporated in the H.T. negative lead and is located in a screw-in holder at the back of the chassis. It is an Osram bulb rated at 3.5 volts .15 amp.

The aerial and earth connections take the form of two leads, the red being the aerial and the green the earth. Sockets at the rear of the chassis enable an

external speaker to be operated. This should be of the moving-coil type, with a matching transformer having an impedance of some 18,000 to 20,000 ohms.

For the output stage either a Cossor 220 O.T. or a Cossor 220 H.P.T. may be used.

Chassis Removal.—There is a false bottom to the cabinet. If it is necessary to remove the chassis follow this procedure:—

First remove the four control knobs on the front of the cabinet. These are of the grub screw fixing type. The concentric trimmer on the tuning knob is removed by taking off the nut at its centre.

Remove the two blue leads connected to the speaker transformer (held by terminals) and take out the two wood screws that secure the wavelength dial assembly. The four bolts and washers holding the chassis to the shelf may now be removed.

RESISTANCES

R.	Purpose.	Ohms.
1	V1 grid bias decoupling ..	2 meg.
2	Volume control ..	50,000
3	Osc. grid leak ..	50,000
4	V1 screen decoupling ..	50,000
5	V1 anode decoupling ..	10,000
6	V2 grid stabiliser ..	200
7	V2 grid leak ..	2 meg.
8	V2 regeneration modifier ..	200
9	V2 anode load ..	50,000
10	V2 screen decoupling ..	500,000
11	V3 grid stopper ..	100,000
12	Tone control (fixed) ..	30,000

CONDENSERS

C.	Purpose.	Mfds.
1	Series aerial ..	.0005
2	V1 grid bias decoupling ..	.1
3	V1 screen decoupling ..	.1
4	V1 anode decoupling ..	.1
5	V2 grid ..	.0001
6	V2 screen decoupling ..	.1
7	H.F. bypass ..	.00005
8	Tone control ..	.0001
9	L.F. coupling ..	.1
10	H.T. reservoir ..	2.
11	Tone control ..	.005
12	Osc. grid ..	.00025
13	S.W. padding ..	.00118

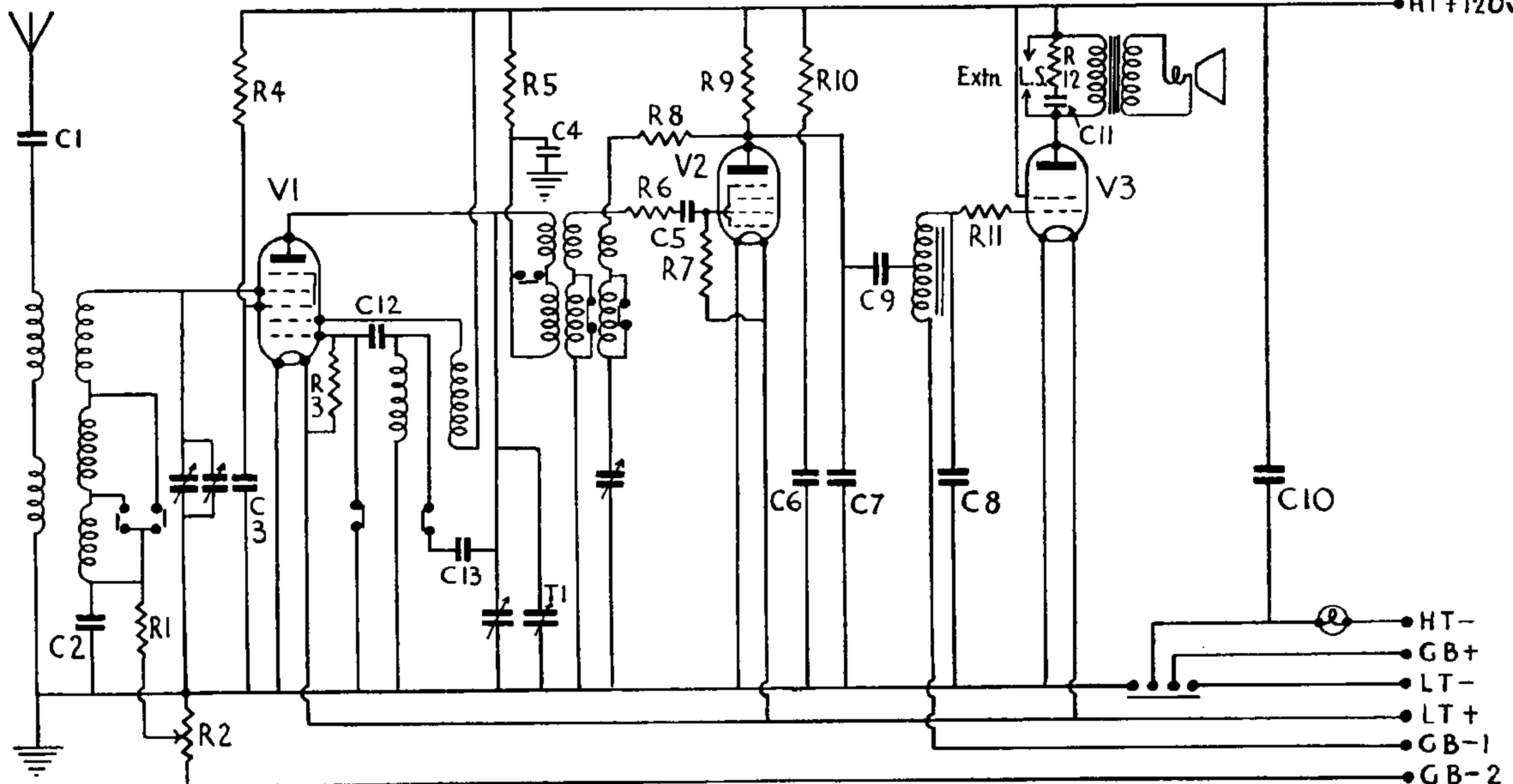

The circuit of the 338 is quite straightforward, and the straight-superhet conversion is effected by simple switching. The output valve is one of the new tetrodes

Circuit Alignment Notes

The circuit of the receiver is so arranged that when it is ganged on the medium waveband the long and short wave bands automatically come into line.

Connect an output meter across the sockets provided for connecting an external speaker. Feed the output from a service oscillator into the aerial and earth leads. Set the reaction control about half-way on but not sufficiently to make the set oscillate. Turn the volume control to the maximum position.

Tune the service oscillator to 1,000 kcs. and set the pointer of the receiver to coin-

VALVE READINGS				
No Signal. Volume Maximum. New Batteries. 1,000 ohms per volt meter.				
V.	Type.	Electrode.	Volts.	Ma
1	All Cossor. 210 S.P.G. Met. (7)	Anode ..	90	1.4
		Screen ..	33	1.6
		Osc. Anode	118	2.2
2	210 S.P.T. Met. (7)	Anode ..	44.5	.83
		Screen ..	14	.2
3	220 O.T. (5) ..	Anode ..	114	2.8
		Screen ..	118	.56

cide with 300 metres on the wavelength dial.

Adjust T1, accessible through a hole in the front of the chassis until maximum response is indicated in the output meter.

As these two chassis layout diagrams show, the Cossor 338 follows logical lines in construction. The top of chassis layout is on the right and, as with all "top deck" diagrams in "Service Engineer," is tinted to facilitate reference.

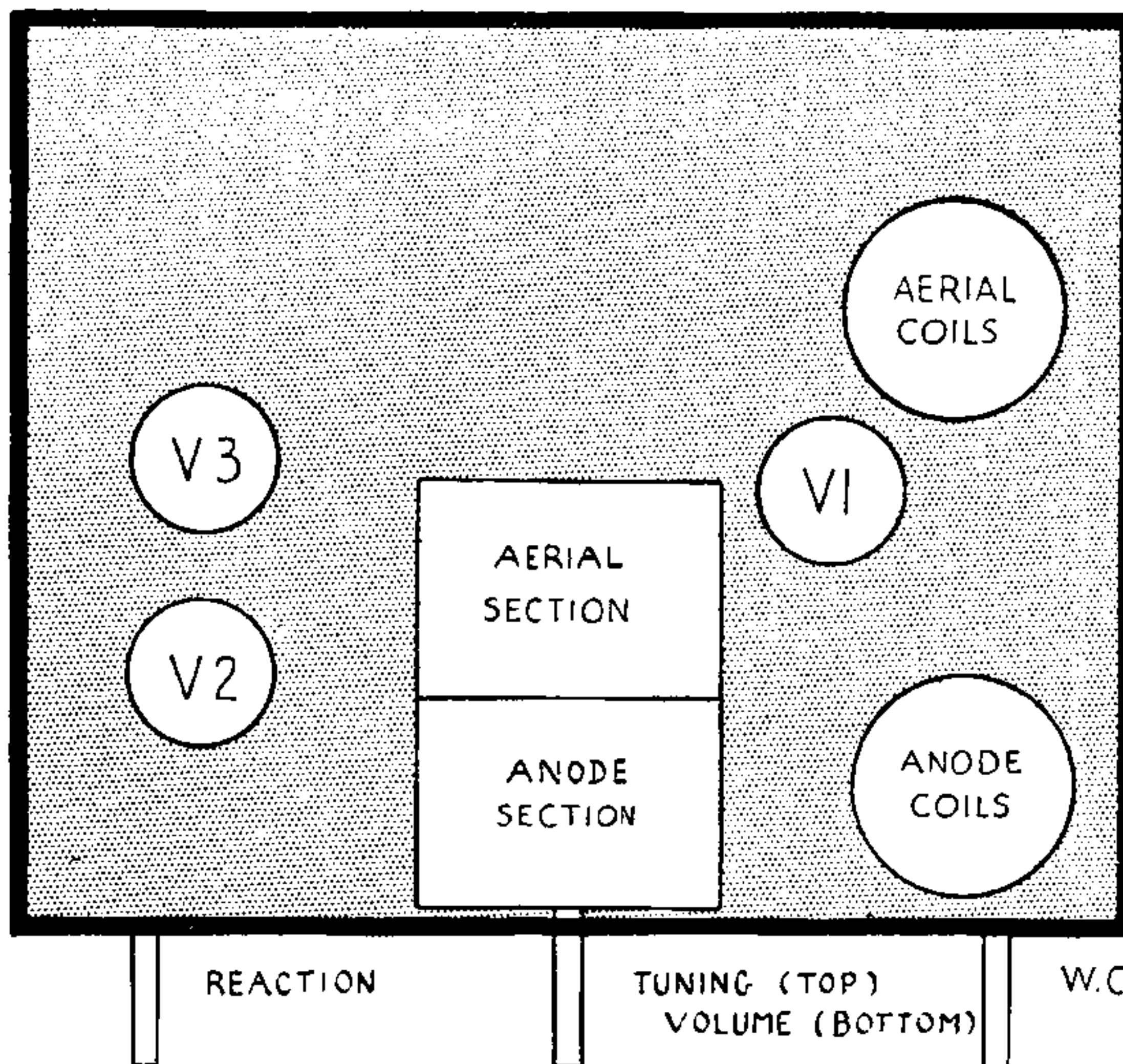

Cossor 338 on Test

MODEL 338.—Standard model for battery operation, requiring a Cossor E.370 2-volt 70-ah. accumulator, a Cossor 120-volt H.T. battery, standard capacity, type 1120 or 2120, and a Cossor 933 9-volt grid bias battery.

DESCRIPTION.—A three-valve, battery operated, three-band receiver operating as a straight set on M.W. and L.W. and as a superhet on S.W.

FEATURES.—Full-vision scale with name and wave calibration. Controls for tuning, wave selection, volume and reaction. Sockets for extension speaker. Protective fuse at rear of chassis.

LOADING.—H.T., 8.8 ma.; L.T., .4 amp.

Selectivity and Sensitivity

SHORT WAVES (17-53 metres).—Very satisfactory gain helped by reaction control, well maintained and tuning quite easy. Good selectivity.

MEDIUM WAVES (200-560 metres).—Good gain; best at the beginning of the scale. Selectivity satisfactory for a straight set. Appreciable local station spread. Careful adjustment of reaction and volume enables number of stations to be received between locals.

LONG WAVES (800-2,000 metres).—Excellent gain and representative selectivity. All usual stations easily separated.

Acoustic Output

Good for battery set, with a well-balanced tone and crisp, clean speech. Music very pleasing, with adequate volume for an ordinary room.

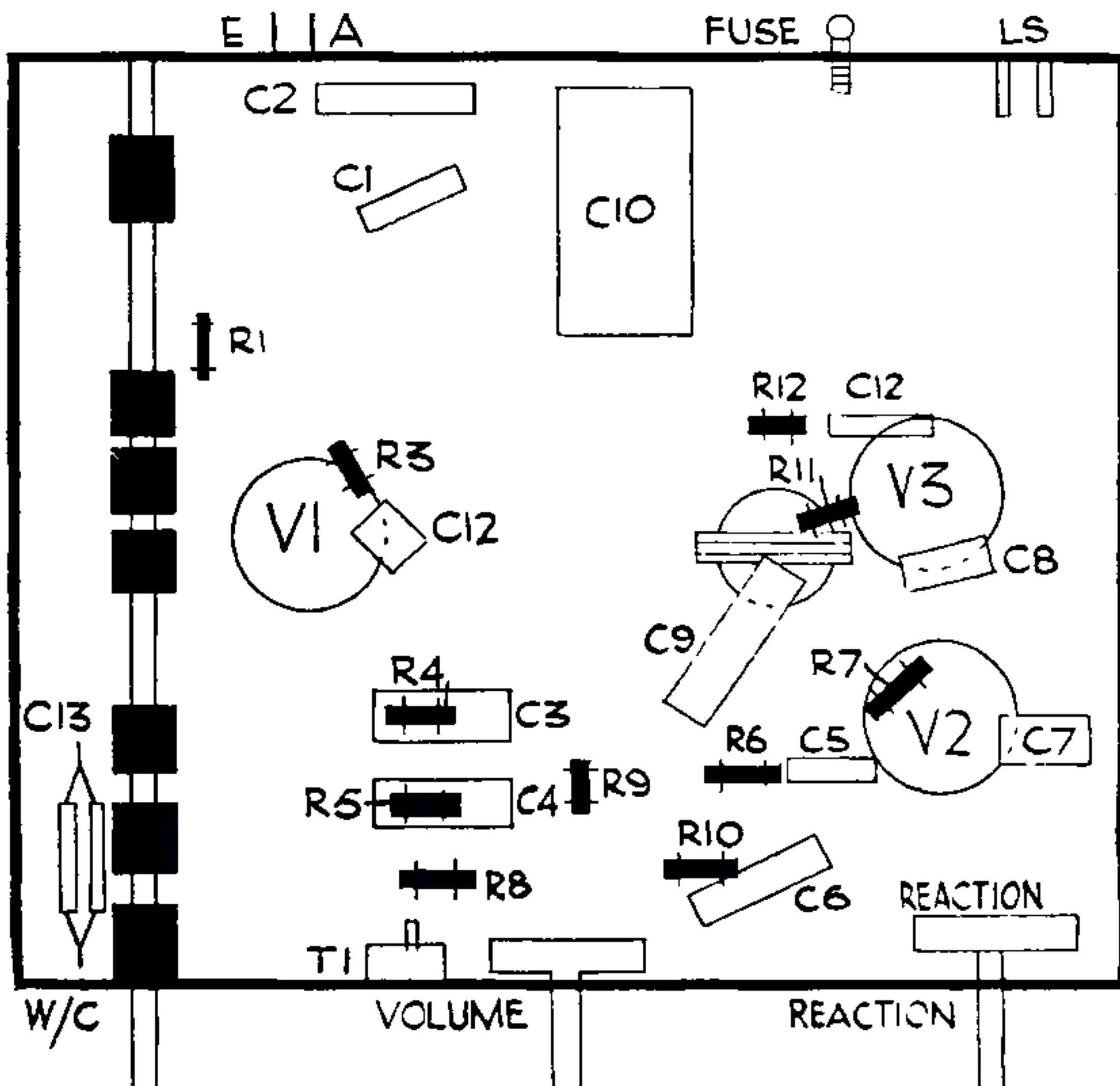

Left is the layout identifying the components underneath the Cossor chassis. Nearly all the parts are suspended in the wiring. Resistors are drawn in solid black.