

"TRADER" SERVICE SHEET

951

BUSH AC11, DAC11

A.C. and A.C./D.C. Superhets

QUICK-RELEASE facilities are a feature of the Bush AC11 receiver, whose chassis is held only by two push-in pegs and two fixing screws. The receiver is a 4-valve (plus rectifier), 3-band superhet, designed to operate from A.C. mains of 100-250 V, 40-100 c/s. Wavebands are 16-50 m, 182-560 m, 830-2,068 m.

Another feature of the design is that the A.C. model can easily be converted to the A.C./D.C. model DAC11. The differences are very small, and the same valves are used in the same heater sequence. The differences between the two are explained in "Circuit Description," which is written basically on the A.C. model.

Release date and original price, both models: June 1949; £17 13s. 7d. Purchase tax extra.

CIRCUIT DESCRIPTION

Input from external aerial is passed via socket A1 and coupling coils L1 (S.W.), L2 (M.W.) or L3 (L.W.) to single-tuned

circuits L4, C34 (S.W.), L5, C34 (M.W.) or L6, C34 (L.W.), which precede first valve (V1, Mullard UCH42) operating as frequency changer with internal coupling.

A second aerial socket A2 is intended for use when interference is experienced from the local station, or when a very long aerial is used. It inserts the series capacitor C1 in the aerial lead. A frame aerial winding L7, connected via sockets 5, 6 permits the receiver to be operated without an aerial. In the A.C./D.C. model, isolating capacitors C39 and C40 are inserted in the aerial and earth leads.

V1 triode oscillator grid coils L8 (S.W.), L9 (M.W.) and L10 (L.W.) are tuned by C35. Parallel trimming by C36 (S.W.), C37 (M.W.) and C14, C38 (L.W.); series tracking by C12 (M.W.) and C13 (L.W.), but tracking adjustments are made by manipulating the iron-dust cores of the tuning coils. Reaction coupling from anode is provided by coils L11 (S.W.), L12 (M.W.) and L13 (L.W.).

Second valve (V2, Mullard UF41) is a variable- μ R.F. pentode operating as

intermediate frequency amplifier with tuned-primary, tuned-secondary transformer couplings C8, L14, L15, C9 and C18, L16, L17, C19.

Intermediate frequency 465 kc/s.

Diode second detector is part of double diode triode valve (V3, Mullard UBC41). Audio frequency component in rectified output is developed across load resistor R11 and passed via I.F. stopper R12, coupling capacitor C24 and manual volume control R13 to control grid of triode section, which operates as an A.F. amplifier.

I.F. filtering by C21, R12 in diode circuit, and C28 in triode anode circuit. Provision for connection of a gramophone pick-up across R13, via C24 and C25. In A.C./D.C. models two isolating capacitors C41, C42 are inserted in the leads, and R25 is added.

Second diode of V3, fed from a tapping on L16 via C23, provides D.C. potential which is developed across load resistor R17 and fed back via decoupling circuits as G.B. to F.C. and I.F. valves, giving automatic gain control.

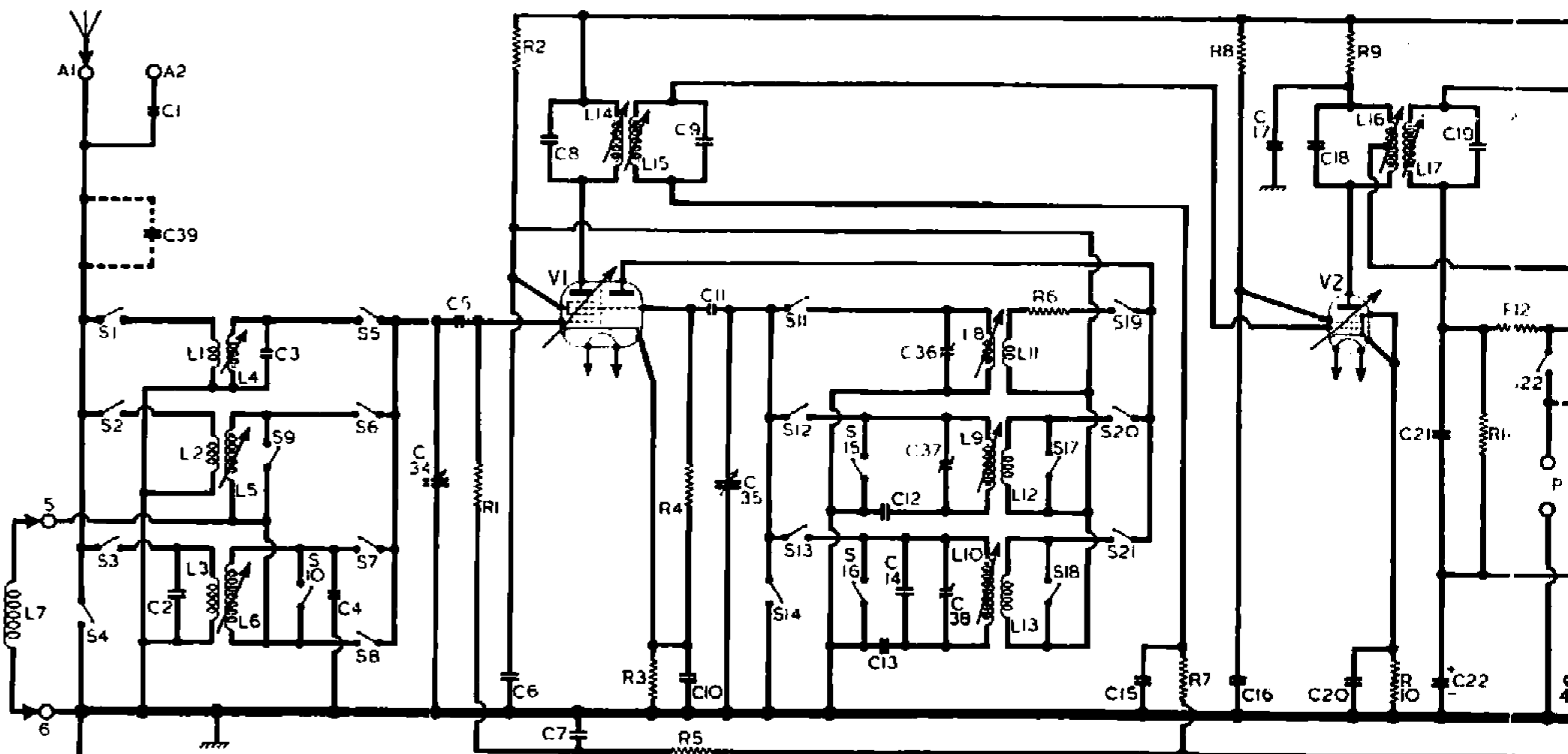

Circuit diagram of the Bush AC11 superhet for A.C. mains. Inset beneath the circuit is the diagram of the DAC11 mains input circuit, which replaces the A.C. input circuit (shown connected) in the A.C./D.C. model. Other changes in the A.C./D.C. version are indicated by connections made with broken lines.

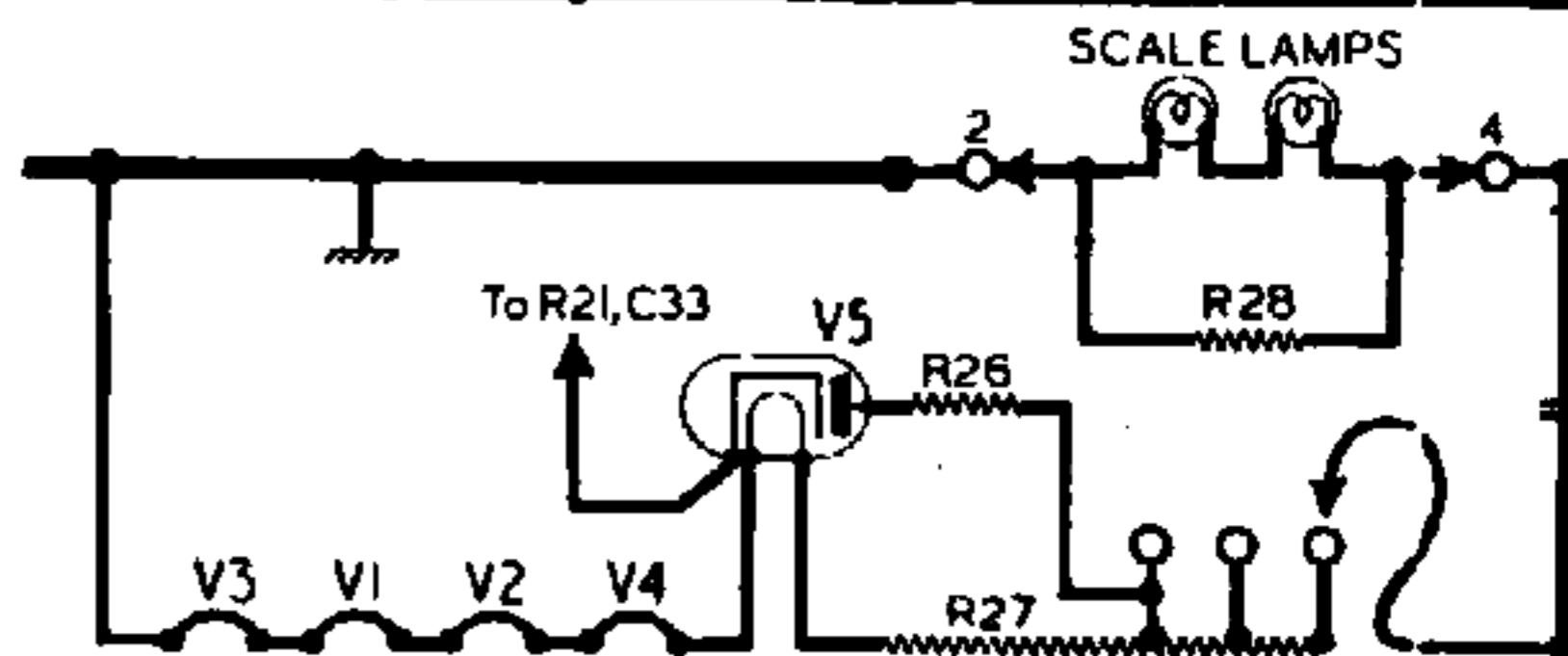

Resistance-capacitance coupling by R15, C29 and R18, via grid stopper R19, between V3 anode and pentode output valve (V4, Mullard UL41). Fixed tone correction by C31, R24 and C32 in anode circuit. Variable tone control by R22, C30, also in anode circuit.

In addition, voltages developed across R23 in V4 cathode circuit are fed back via a frequency-selective network R20, C26, C25, R14 to V3 triode control grid circuit. Provision is made for the connection of a low impedance external speaker across the secondary of the output transformer T1, while switch S23 permits the internal speaker to be muted.

In the A.C. model, H.T. current is supplied by half-wave rectifying valve (V5, Mullard UY41), which is fed from the complete secondary winding of the double-wound mains transformer T2. Smoothing is effected by resistor R21 and electrolytic capacitors C27, C33. Valve heaters are connected in series between tappings 7 and 12 (116.6 V) on T2 secondary, and the scale lamps are connected in series between tappings 7 and 10 (9 V).

In the A.C./D.C. model, the A.C. mains input circuit which we show connected in our circuit diagram is replaced by the mains input circuit we show inset beneath the circuit diagram, to the left of the A.C. mains circuit. Here the transformer is replaced by the tapped ballast resistor R27, but the valve types and their heater

sequence remain unaltered. The scale lamps, however, are connected in series with the mains input lead to the chassis and are shunted by R28. They carry the heater and H.T. current. L19, L20 and C43 filter out mains-borne interference.

COMPONENTS AND VALUES

RESISTORS	Values	Locations
R1	V1 hex. C.G. ...	470kΩ F4
R2	H.T. feed ...	15kΩ F4
R3	V1 fixed G.B. ...	220Ω F3
R4	V1 osc. C.G. ...	47kΩ F3
R5	A.G.C. decoupling ...	1MΩ E4
R8	S.W. osc. stabilizer ...	47Ω G4
R7	A.G.C. decoupling ...	2.2MΩ E4
R8	V2 S.G./H.T. feed ...	47kΩ E4
R9	V2 anode decoup. ...	10kΩ E4
R10	V2 fixed G.B. ...	330Ω E4
R11	Sig. diode load ...	330kΩ E4
R12	I.F. stopper ...	100kΩ E3
R13	Volume control ...	2MΩ E3
R14	F.B. resistor ...	4.7kΩ E3
R15	V3 anode load ...	150kΩ D4
R16	V3 G.B. ...	5.6kΩ D4
R17	A.G.C. diode load ...	1MΩ E4
R18	V4 C.G. ...	470kΩ D4
R19	Grid stopper ...	47kΩ E4
R20	F.B. resistor ...	330Ω D4
R21	H.T. smoothing ...	10kΩ C4
R22	Tone control ...	50kΩ C3
R23	V4 G.B. ...	220Ω D4
R24	Fixed tone correct ...	10kΩ —
R25	P.U. coupling ...	47kΩ E3
R26	Surge limiter ...	150Ω B2
R27	Heater ballast ...	1.25kΩ† B2
R28	Scale lamp shunt ...	250Ω —

† tapped at 950Ω + 150Ω + 150Ω from V5 heater.

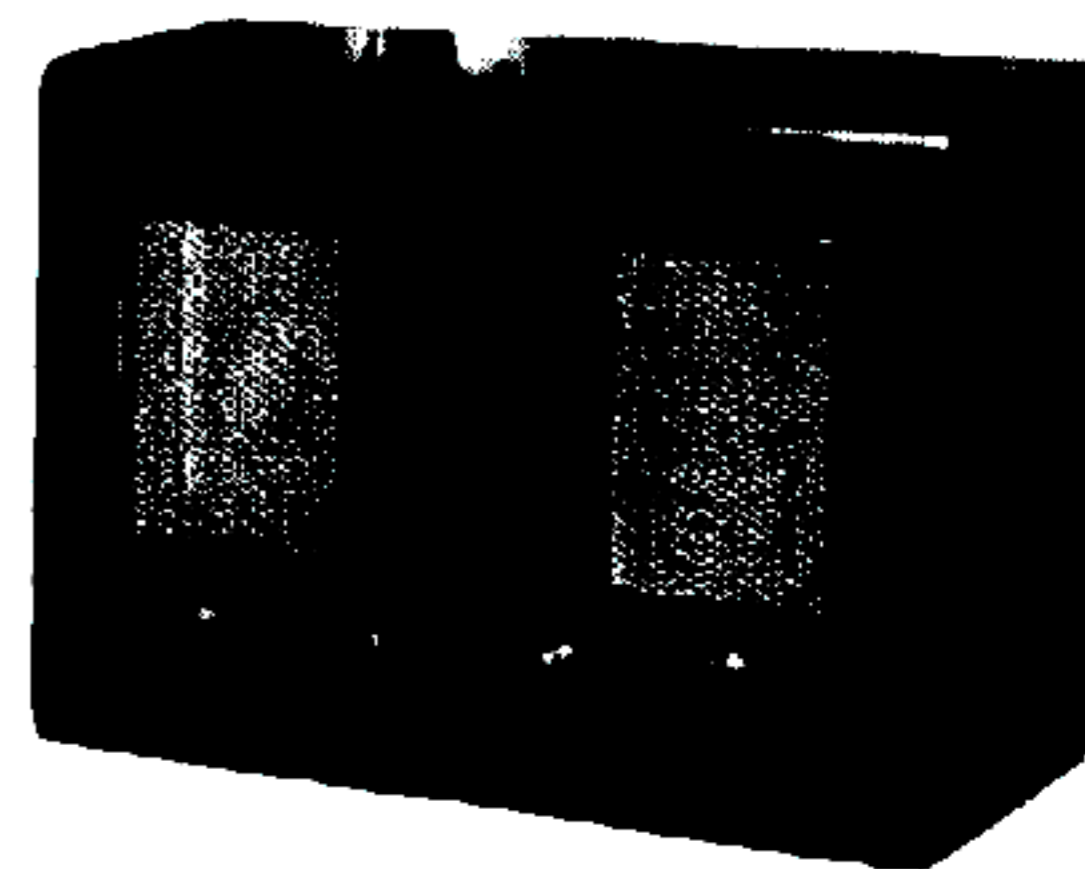

CAPACITORS	Values	Locations
C1	Aerial series ...	50pF G4
C2	L.W. aerial shunt ...	800pF G4
C3	S.W. aerial trim. ...	20pF H4
C4	L.W. aerial trim. ...	60pF G4
C5	V1 hex. C.G. ...	50pF G4
C6	V1 H.T. decoup. ...	0.05μF F4
C7	A.G.C. decoupling ...	0.1μF F4
C8	1st I.F. trans. tuning ...	110pF A2
C9	110pF A2	
C10	V1 cath. by-pass ...	0.05μF F3
C11	V1 osc. C.G. ...	50pF G3
C12	Osc. M.W. tracker ...	556pF G3
C13	Osc. L.W. tracker ...	390pF G3
C14	Osc. L.W. trim. ...	180pF G3
C15	A.G.C. decoupling ...	0.05μF F4
C16	V2 S.G. decoupling ...	0.05μF F4
C17	V2 anode decoup. ...	0.05μF E4
C18	2nd I.F. trans. tuning ...	110pF B2
C19	110pF B2	
C20	V2 cath. by-pass ...	0.05μF E4
C21	I.F. by-pass ...	100pF E4
C22*	V3 cath. by-pass ...	50μF D3
C23	A.G.C. coupling ...	50pF E4
C24	A.G. coupling ...	0.01μF E3
C25	F.B. capacitors ...	0.1μF E3
C26	0.05μF D4	
C27*	H.T. smoothing ...	16μF B1
C28†	I.F. by-pass ...	0.002μF D4
C29	A.F. coupling ...	0.01μF D4
C30	Part tone control ...	0.05μF C3
C31	Part tone correct ...	0.001μF C3
C32	Part tone correct ...	0.01μF —
C33*	H.T. smoothing ...	32μF B1
C34†	Aerial tuning ...	528pF A1
C35†	Oscillator tuning ...	528pF A1
C36†	Osc. S.W. trim ...	40pF G3
C37†	Osc. M.W. trim. ...	40pF G3
C38†	Osc. L.W. trim. ...	40pF G3
C39	Aerial isolator ...	0.005μF G4
C40	Earth isolator ...	0.01μF G4
C41	P.U. isolators ...	0.005μF H4
C42	0.1μF D3	
C43	Mains R.F. by-pass ...	0.01μF B2

* Electrolytic. † Variable. ‡ Pre-set.

OTHER COMPONENTS	Approx. Value (ohms)	Locations
L1	—	H4
L2	0.6	G4
L3	32.0	G4
L4	—	—
L5	4.0	G4
L6	16.0	G4
L7	0.3	—
L8	—	G3
L9	3.2	G3
L10	4.0	F3
L11	—	G3
L12	0.6	G3
L13	1.5	F3
L14	12.5	A2
L15	12.5	A2
L16	12.5	B2
L17	12.5	B2
L18	2.5	—
L19	3.0	B2
L20	3.0	B2
T1	500.0	—
T2	42.0	—
T3	177.5	D3
T4	40.0	—
T5	3.2	—
S1-S22	—	G4
S23	—	—
S24	—	—
S26	—	E3

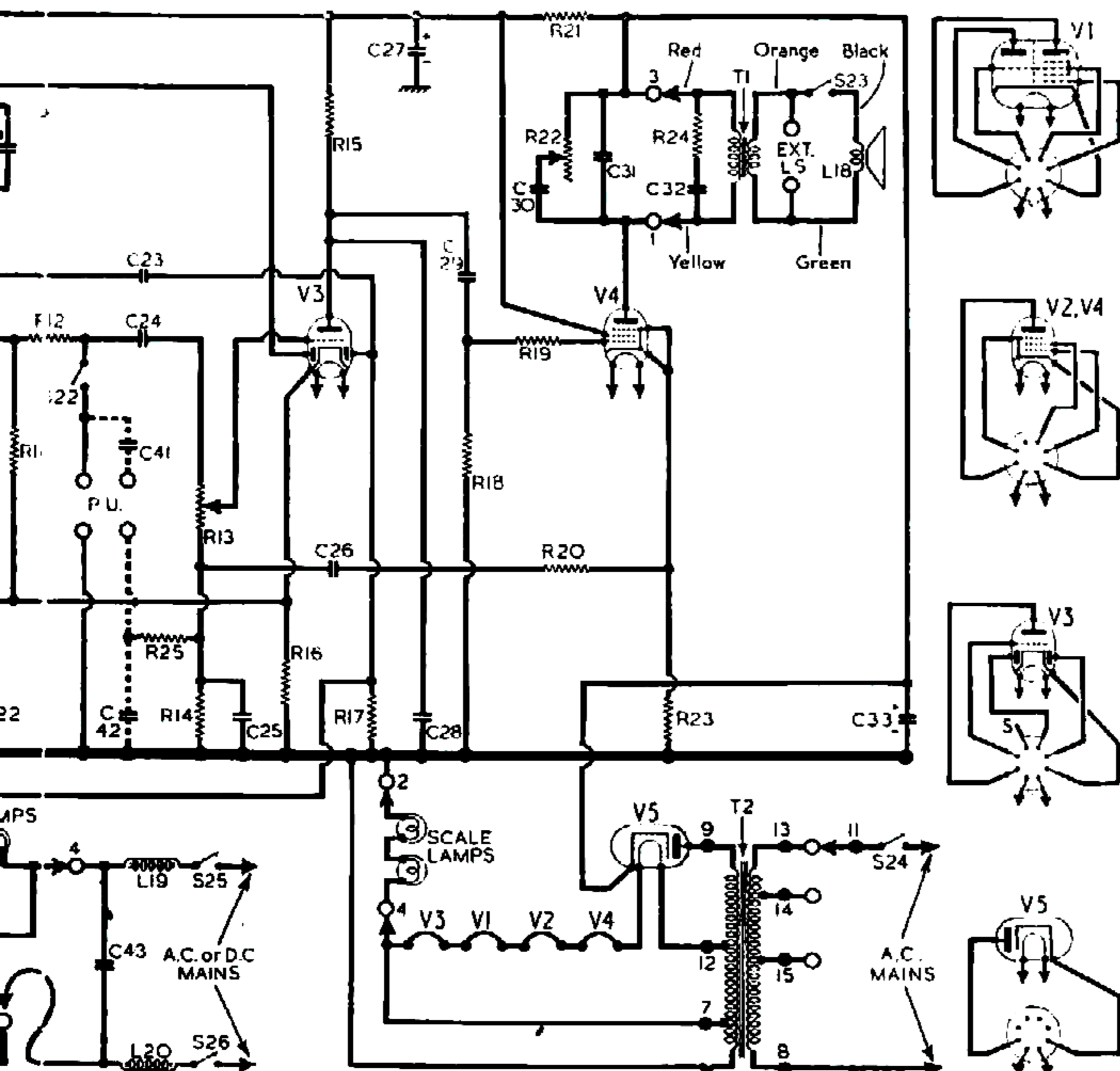

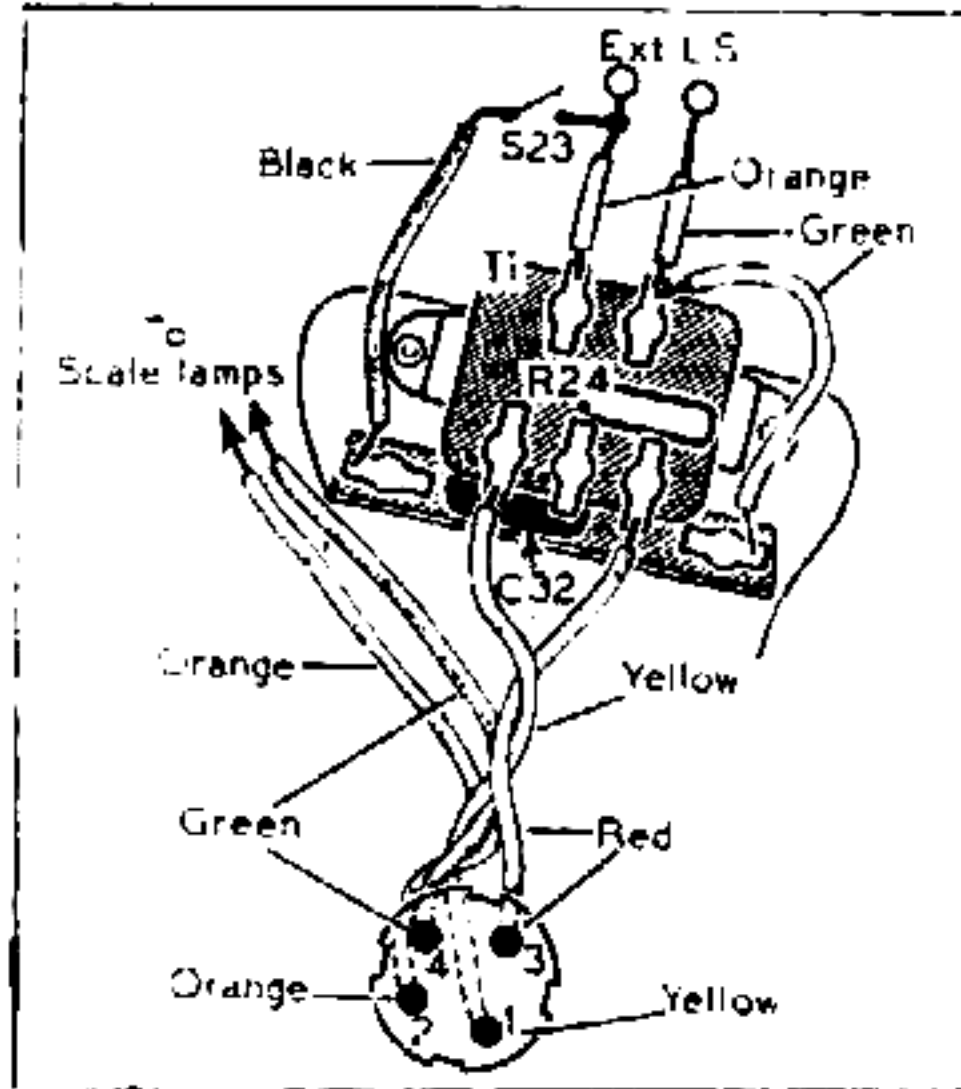

Sketch of the speaker connections as seen from the rear. The plug is viewed from the free ends of its pins.

GENERAL NOTES

Switches.—S1-S21 are the waveband and radio muting switches, and S22 is the pick-up switch, ganged in two rotary units beneath the chassis. These units are indicated in our under-chassis view, where they are identified by the numbers 1 and 2 in diamonds, and shown in detail in the diagrams in col. 3, where they are drawn as seen when viewed from the rear of an inverted chassis.

The table (col. 3) gives the switch positions for the four control settings, starting from the fully anti-clockwise position of the control spindle. A dash indicates open, and C, closed.

S23 is a screw-type switch mounted with the external speaker sockets at the top right-hand corner of the cabinet. It opens when screwed a few turns anti-clockwise to mute the internal speaker.

S24 is the Q.M.B. mains switch in the A.C. model, ganged with the volume control R13. In the A.C./D.C. model it is replaced by S25, S26.

Scale Lamps.—In the A.C. model these are two M.E.S. types, with large clear spherical bulbs, rated at 6.2 V, 0.3 A. In the A.C./D.C. model they have smaller diameter bulbs and are rated at 3.5 V,

0.15 A. In both cases they are connected via pins 2 and 4 of the speaker connecting plug. In the A.C./D.C. model the lamps are mounted on a panel which can be withdrawn after removing two nuts. R28 is mounted with them.

External Speaker.—Two sockets are provided on a panel mounted at the top right-hand corner of the cabinet for the connection of a low impedance (about 2.5 Ω) speaker. The screw-type switch S23 mounted with them permits the internal speaker to be muted.

Connecting Plugs.—A 4-pin plug and socket device is used to connect the speaker and scale lamps to the chassis. The socket is located at one end of the chassis, where it is indicated on the left in our under chassis view.

The plug and its connecting leads are shown, together with the leads associated with the speaker, in the sketch in col. 1, where the speaker transformer T1 is drawn as seen from the rear of the cabinet and the plug is viewed from the free ends of its pins, which are numbered 1-4.

The frame aerial winding L7 is connected via a 2-pin plug and socket whose pins are numbered 5 and 6. The socket is indicated on the left of our plan view of the chassis. The larger pin (6) goes to chassis.

Chassis Divergency.—R16, which was 5.6 kΩ in our chassis, was 3.3 kΩ in earlier models.

VALVE ANALYSIS

Valve voltages and currents given below are those quoted by the manufacturers for the A.C. model only, which was operating from A.C. mains of 230 V using the 210 230 V tapping on T2. A similar set of readings taken on a model DAC11 were found to be approximately 25 per cent lower than those in the A.C. model. The receiver was tuned to M.W. and there was

Valve	Anode Voltage (V)	Screen Voltage (V)	Cathode (V) (mA)
V1 UCH42	120 Oscillator	80	1.2 6.0
V2 UF41	84	62	1.5 5.0
V3 UBC41	60	—	0.8 0.2
V4 UL41	260	120	8.0 35.0
V5 UY41	263†	—	282.0 46.0

† A.C.

Switch	S.W.	M.W.	L.W.	Gram.
S1	0	—	—	—
S2	—	0	—	—
S3	—	—	0	—
S4	—	—	—	0
S5	0	—	—	0
S6	—	0	—	—
S7	—	—	0	—
S8	—	—	—	0
S9	0	—	—	0
S10	0	—	—	0
S11	—	—	0	—
S12	—	—	—	0
S13	—	—	0	—
S14	—	—	—	0
S15	0	—	—	—
S16	—	0	—	—
S17	—	—	0	—
S18	—	—	—	0
S19	—	—	—	0
S20	—	0	—	—
S21	—	—	0	—
S22	—	—	—	0

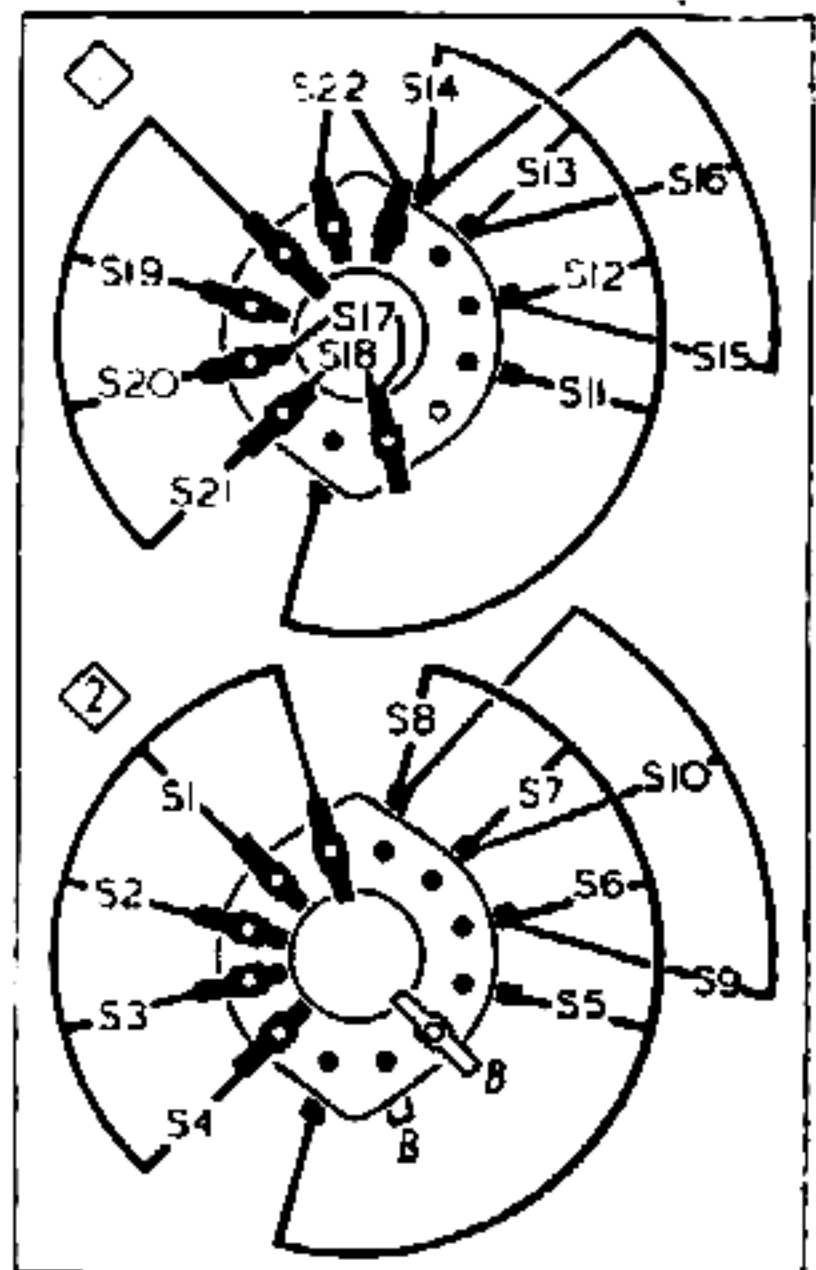

Diagrams of the waveband switch units, viewed from the rear of an inverted chassis. The associated table is above them.

no signal input. Anode and screen currents were not quoted.

Except for cathode readings, all voltages were measured on the 1,000 V range of a model 7 Avometer, chassis being the negative connection.

DISMANTLING THE SET

Removing Chassis.—Remove the four control knobs (pull off); withdraw the frame aerial and speaker plugs located at opposite ends of the chassis; remove the two chassis retaining bolts (with one large washer and spacing collar each) from the rear lower corners of the chassis; withdraw chassis about one inch and ensure that the cursor carriage clip disengages with the cursor carriage and remains on the drive cord; completely withdraw chassis. To operate the receiver in this position, insert frame aerial and speaker plugs. When replacing, ensure that the rubber grommets in the front locating brackets

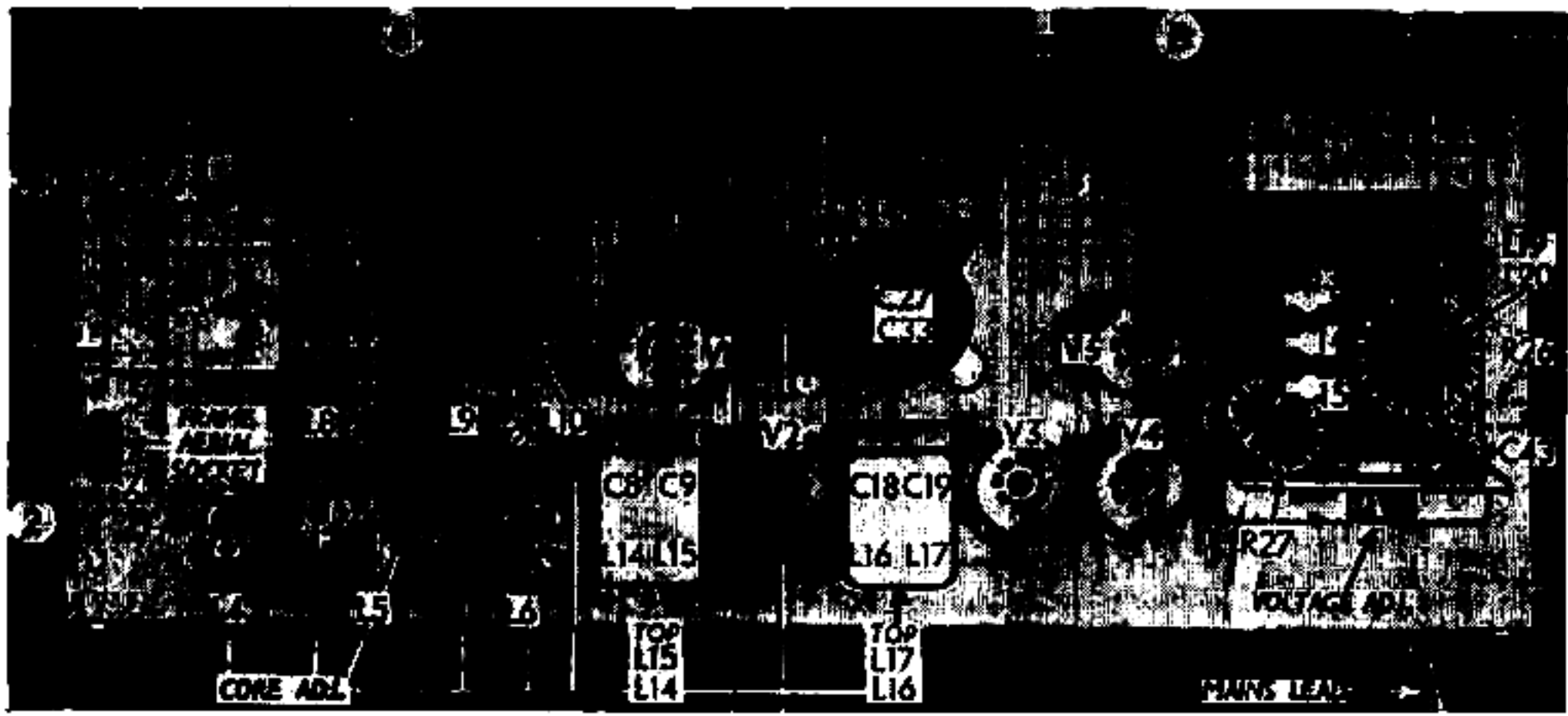

Plan view of the chassis, in which all the core adjustments are indicated.

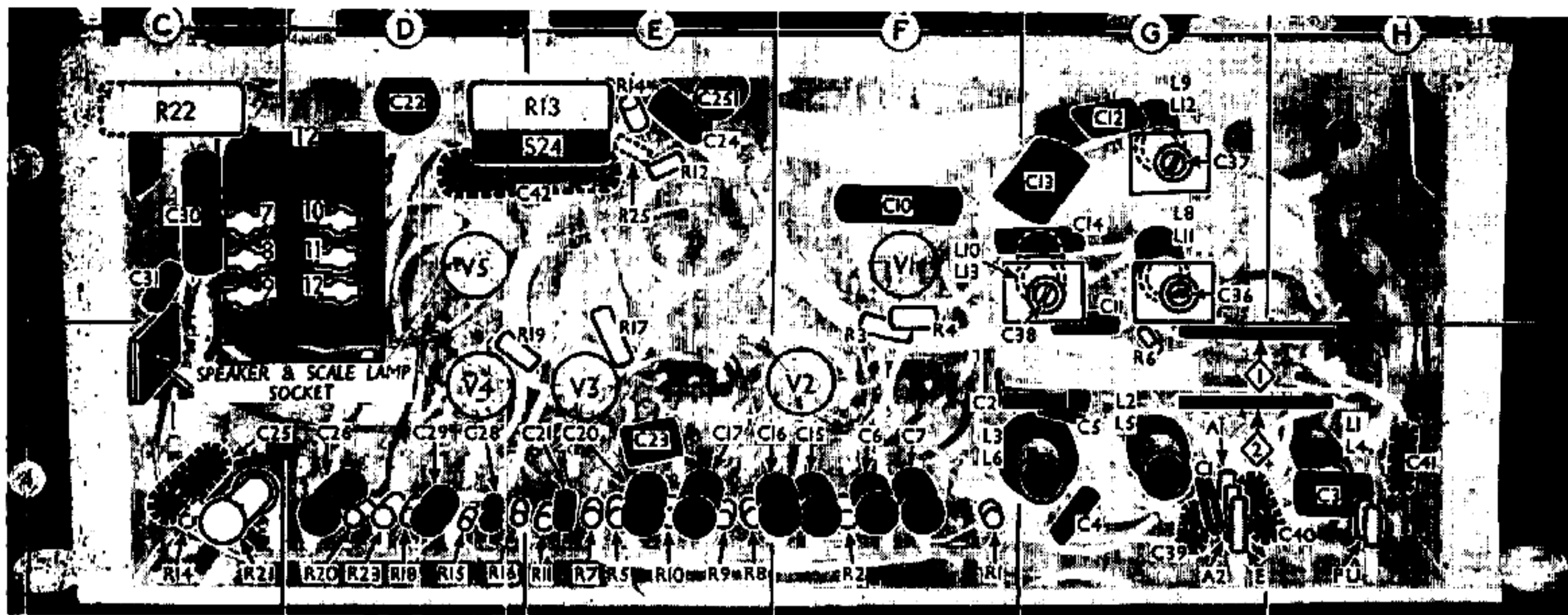

Under-chassis view. Six tags of the mains transformer are numbered here to agree with the circuit diagram overleaf. The other three tags are numbered in our plan view. Detailed diagrams of the waveband switch units 1 and 2 appear in col. 3.

are in position. Do not omit to re-engage the cursor carriage with its driving clip on the drive cord.

Removing Speaker.—Unsolder four connecting wires and remove three 4 BA nuts (with one washer each).

When replacing, the connections should be resoldered as illustrated in our diagram in col. 1.

CIRCUIT ALIGNMENT

I.F. Stages.—Connect signal generator leads via a 0.1 μ F capacitor (use two in the A.C./D.C. receiver) to control grid (pin 6) of V2 and chassis. Switch set to M.W., tune to 300 m on scale, and turn the volume control to maximum. Keep input low to avoid A.G.C. action, reducing input as circuits come into line.

Unscrew all four I.F. cores fully, then feed in a 465 kc/s (645.16 m) signal, and adjust L17, then L16, for maximum output to the first peak encountered. Transfer signal generator lead to control grid (pin 6) of V1 and adjust the cores of L15, then L14, for maximum output in the same way. Do not readjust the cores.

R.F. and Oscillator Stages.—With the gang at maximum, the centre of the cursor should coincide with the datum lines at the long wavelength ends of the scales. It may be adjusted by sliding the cursor drive wedge along the drive cord. In order that alignment may be performed with the chassis out of its cabinet, calibration marks are scaled on the rear of the gang drum, although all adjustments are accessible while the chassis is in the cabinet. The procedure should in any case be completed, however, by readjusting the M.W. and L.W. aerial circuits with the chassis in its cabinet, as the frame winding, which is wound round the inside of the cabinet, forms part of the aerial circuit. The location references are A1, A2 and G3.

L.W.—Transfer signal generator leads to A1 and E sockets via a suitable dummy aerial (a 0.0002 μ F capacitor will do).

Switch set to L.W., tune to 2,000 m on scale, feed in a 2,000 m (150 kc/s) signal, and adjust the cores of L10, then L6, for maximum output. Tune to 1,000 m on scale, feed in a 1,000 m (300 kc/s) signal, and adjust C38 for maximum output. Check calibration at 2,000 m.

M.W.—Switch set to M.W., tune to 500 m on scale, feed in a 500 m (600 kc/s) signal, and adjust the cores of L9, then L5, for maximum output. Tune to 200 m on scale, feed in a 200 m (1,500 kc/s) signal, and adjust C37 for maximum output. Check calibration at 500 m.

S.W.—Switch set to S.W., and change dummy aerial to a 400 Ω non-inductive resistor. Tune to 50 m on scale, feed in a 50 m (60 Mc/s) signal, and adjust the cores of L8, then L4, for maximum output. Tune to 25 m on scale, feed in a 25 m (12 Mc/s) signal, and adjust C36 for maximum output. Check again at 50 m.

Finally, fit chassis into cabinet, connect up frame aerial winding (L7), and re-adjust L5 and L6 cores for maximum output at 500 m and 2,000 m respectively.

DRIVE CORD REPLACEMENT

About three feet of Nylon braided glass yarn is required for a new drive cord, which follows the simple course shown in the sketch below, where the chassis is viewed from the front with the gang at maximum.

It is convenient to make up the cord before fitting into a closed loop, the ends being clamped in the special cord anchor plate (shown inset in our sketch) and tied to prevent slipping. The circumferential

length of the cord when so made up is 32 $\frac{1}{4}$ ins. overall: or it measures 16 $\frac{1}{8}$ ins. when the loop is stretched between two pins stuck in the bench.

Having made the loop, pull it out straight as for the second measurement quoted, and pass the folded end through the hole in the gang drum groove so that the anchor plate is on the inside. Wind the cord three turns round the tuning control spindle in the direction shown in the sketch, and pass over the pulleys and round the drum as shown. Then anchor the tension-spring.

The wedge which drives the cursor carriage should be fitted loosely until the chassis is fitted in the cabinet, when its grip tag can be tightened after correct positioning of the cursor carriage. This should be done as explained under "Circuit Alignment" in col. 4.

It is not permissible to make adjustments of the drum on the gang spindle, as this carries on its rear face a calibrated alignment scale. The line marked "Datum" on this scale should be opposite the brass pointer fixed to the top of the gang frame when the gang is at maximum capacitance.

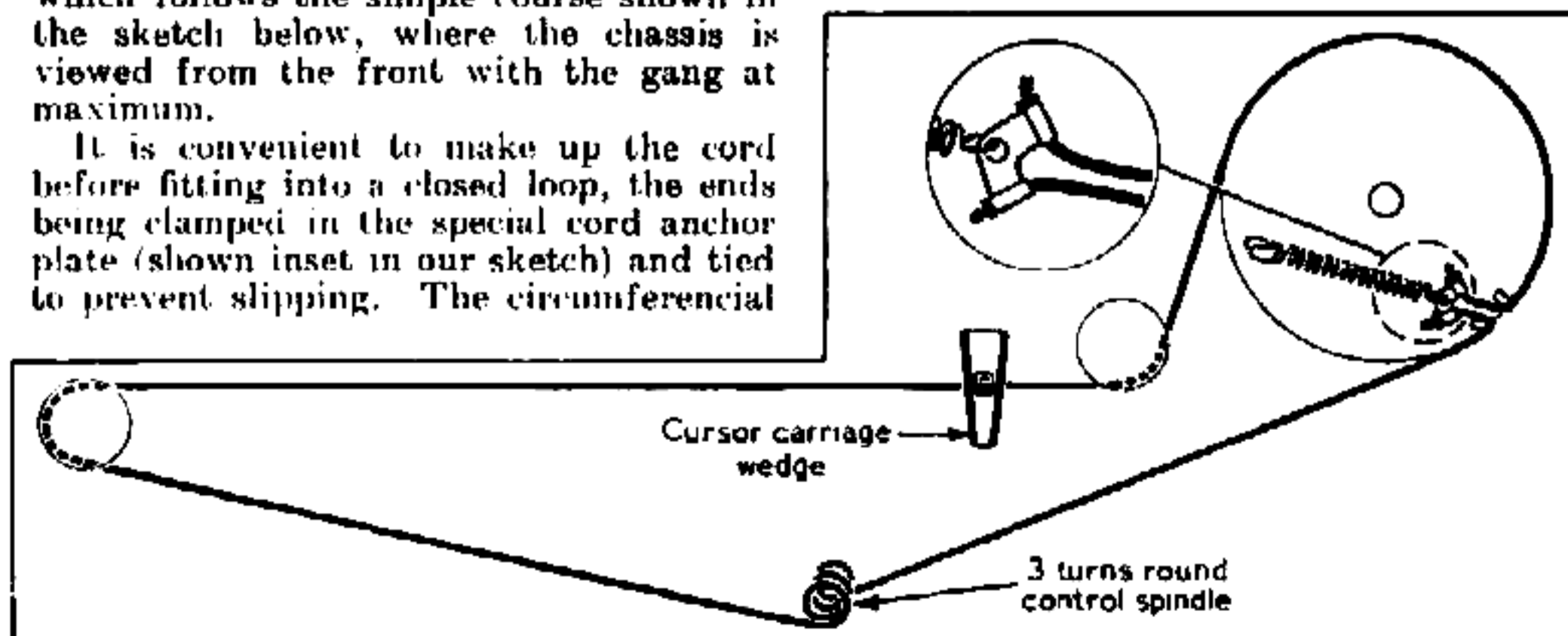

Sketch of the tuning drive cord, with the anchor plate device shown enlarged inset.