

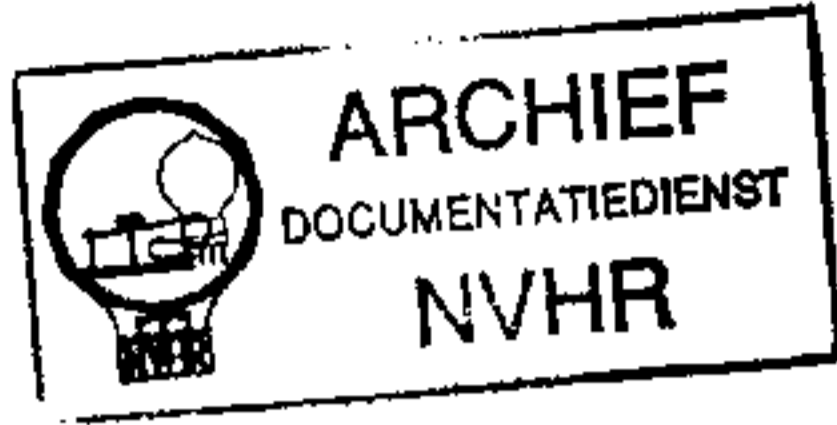

BEOGRAM 1203 and 2000
TYPE 5239 and 5240

Ned. Ver. v. Historie v/d Radio



CONTENTS

	Sect.	Page
Technical data	1	
Disassembly	2	
Diagram	3	
Adjustments	6	
Microswitch for LIFT (ON)	4	1
"Silent" Switch	4	1
Relay	4	1
Motor-voltage Switch	4	2
Switch for Relay Holding Voltage	4	2
Rotor	4	2
Step-cone Pulley	4	3
Motor, Centering	4	3
Motor, Height	4	4
Pickup, Height	4	4
Pickup Arm, Balance	4	4
Pickup Arm, Downstroke	4	5
Pickup, Parallelity	4	5
Dust Cover, BEOGRAM 2000	4	6
Parts list	5	
Beogram 1203	5	1
Beogram 2000	5	9
Modifications	6	

TECHNICAL DATA

	BEOGRAM 1203	BEOGRAM 2000
Type No.	5239	5240
Sound system	Stereo, matrix	Stereo, matrix
Output	2 x 1 mV	2 x 1 mV
Speeds	33-45 rpm	33-45 rpm
Tonearm	Radial	Radial
Pickup cartridge	SP 14 A	SP 10 A
Automatic pickup movement	Yes	Yes
Automatic speed selection	Yes	Yes
Wow and flutter, DIN	< ± 0.15%	< ± 0.12%
Wow and flutter, WRMS	< ± 0.075%	< ± 0.06%
Rumble DIN unweighted	> 35 dB	> 37 dB
Rumble DIN weighted	> 58 dB	> 60 dB
Speed deviation	< 0.1%	< 0.1%
Speed control range	> 6%	> 6%
Dial for speed	Stroboscope 295 mm	Stroboscope 295 mm
Stylus pressure range	0-3.5 gram	0-3.5 gram
Tangential tracking	0.126°/cm	0.126°/cm
Lift system	Mechanical	Mechanical
Antiskating	Inclined channelling inside bearing	Inclined channelling inside bearing
Motor	Asynchronous	Asynchronous
Drive system	Idler wheel and belt	Idler wheel and belt
Turntable	30 cm 1.4 kg	30 cm 1.4 kg
Dust cover	Detachable	Hinged and detachable
Power supply	220 (110) volts	220 (110) volts
Frequency	50 Hz	50 Hz
Power consumption	10 watts	10 watts
Dimensions W x H x D	44 x 11.5 x 33 cm (17,3" x 4,6" x 13,0")	44 x 12 x 33 cm (17,3" x 4,7" x 13,0")
Weight	7.2 kg (15.86 lbs)	7.5 kg (16.52 lbs)
Pick-up	SP 14 A	SP 10 A
Stylus	Spherical diamond	Spherical naked diamond
Radius of curvature	15 µm	15 µm
Frequency range	20-20,000 Hz ± 3 dB 50-16,000 Hz ± 2.5 dB	20-25,000 Hz ± 3 dB 50-16,000 Hz ± 2 dB
Channel separation 1000 Hz	> 20 dB	> 25 dB
400-10,000 Hz	> 15 dB	> 20 dB
Channel difference	< 2 dB	< 2 dB
Intermodulation	< 1%	< 1%
Recommended stylus pressure	2 gram	1.2 gram
Compliance	15 x 10 ⁻⁶ cm/dyne	25 x 10 ⁻⁶ cm/dyne
Effective tipmass	1 mg	0.8 mg
Output mV/cm/sec.	1 mV/47 kohms	1 mV/47 kohms
Subject to change without notice		

ADSKILLELSE
DISASSEMBLY/ZERLEGUNG

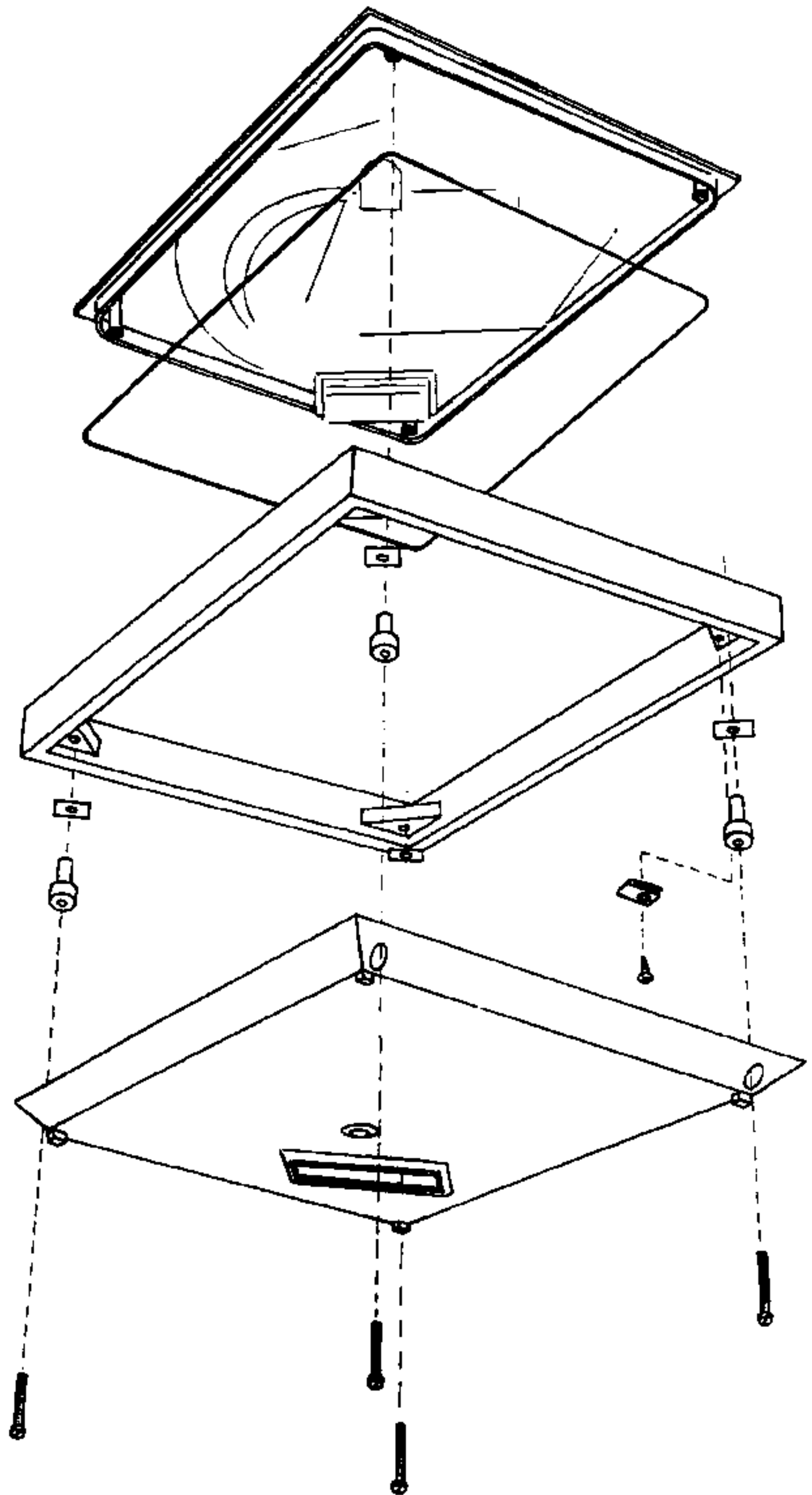

DIAGRAM/SCHALTBILD

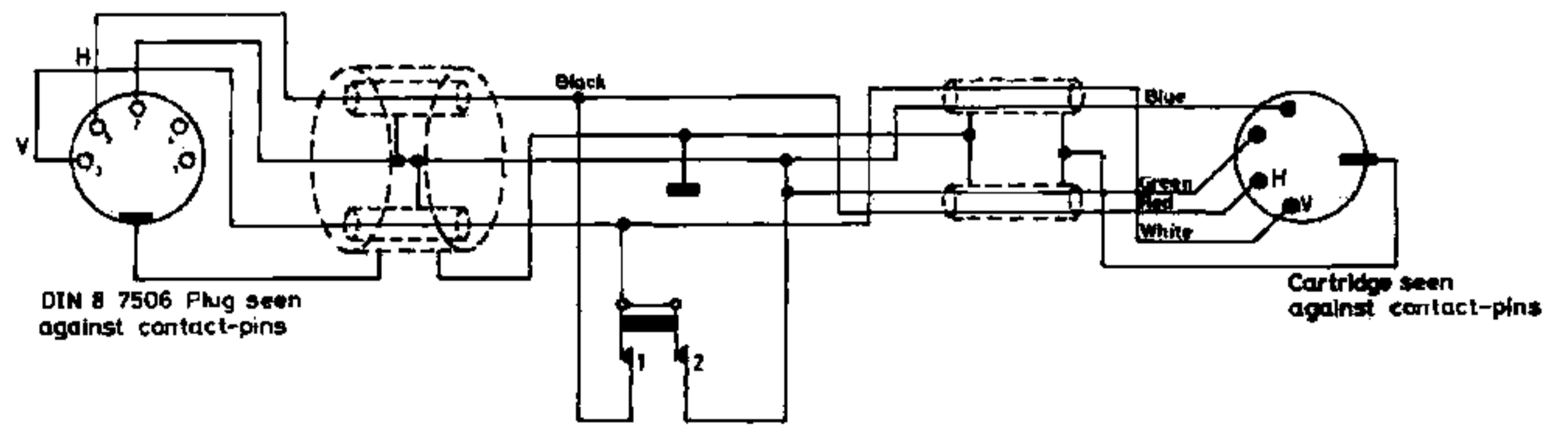
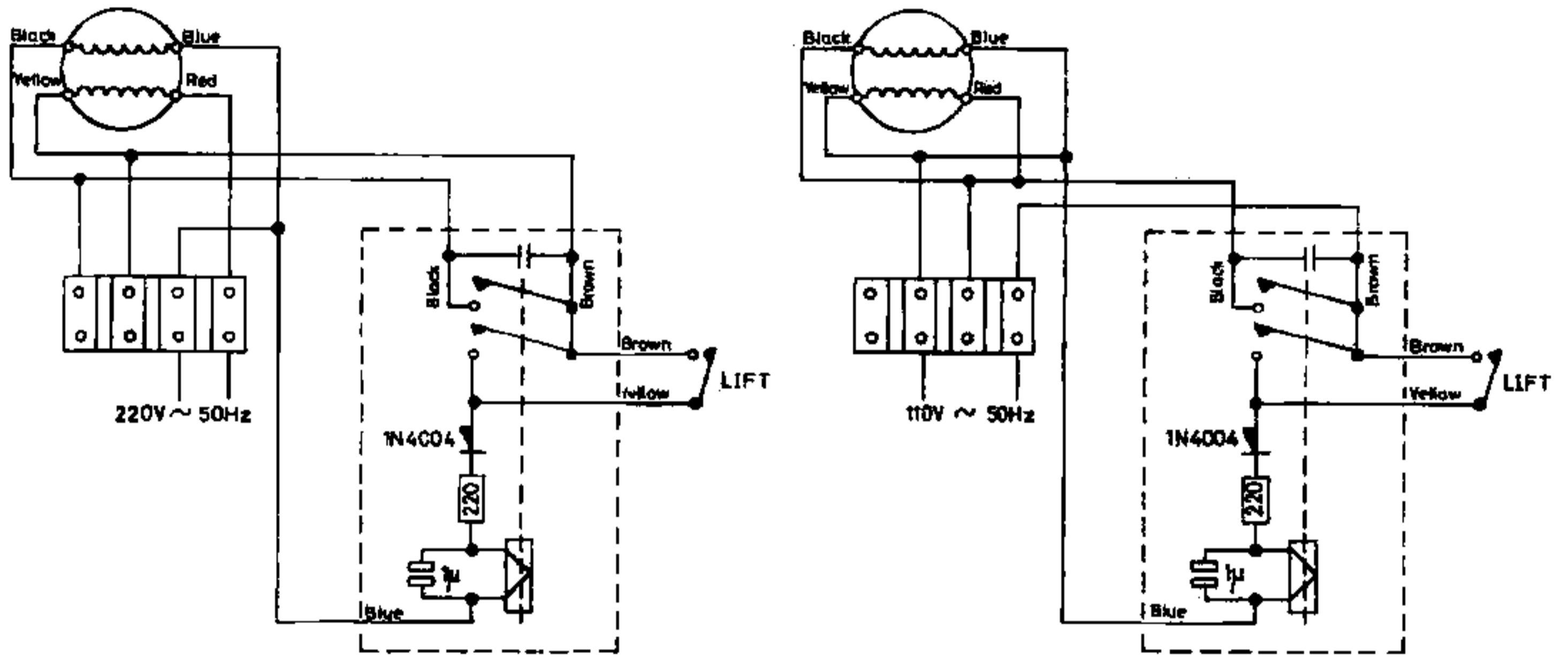

ADJUSTMENTS
Microswitch for LIFT (ON)

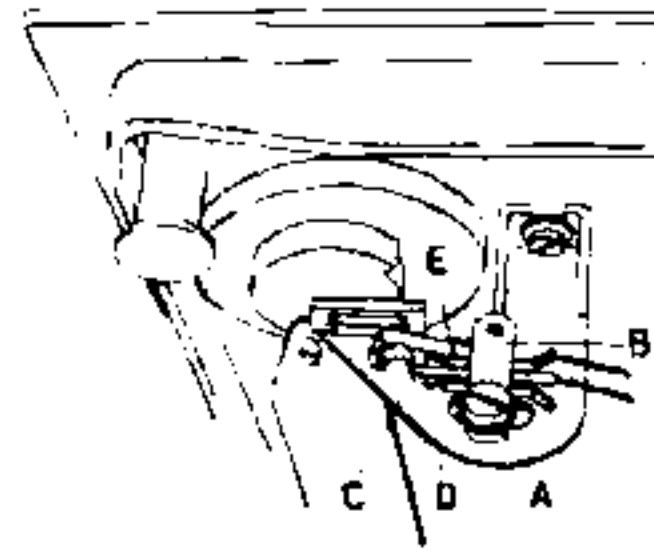

Loosen screw A.

Adjust microswitch B to the point where arm C switches positively from arm D to E and back to D again when the LIFT-button is pressed and thereafter released.

Tighten screw A.

"Silent" Switch

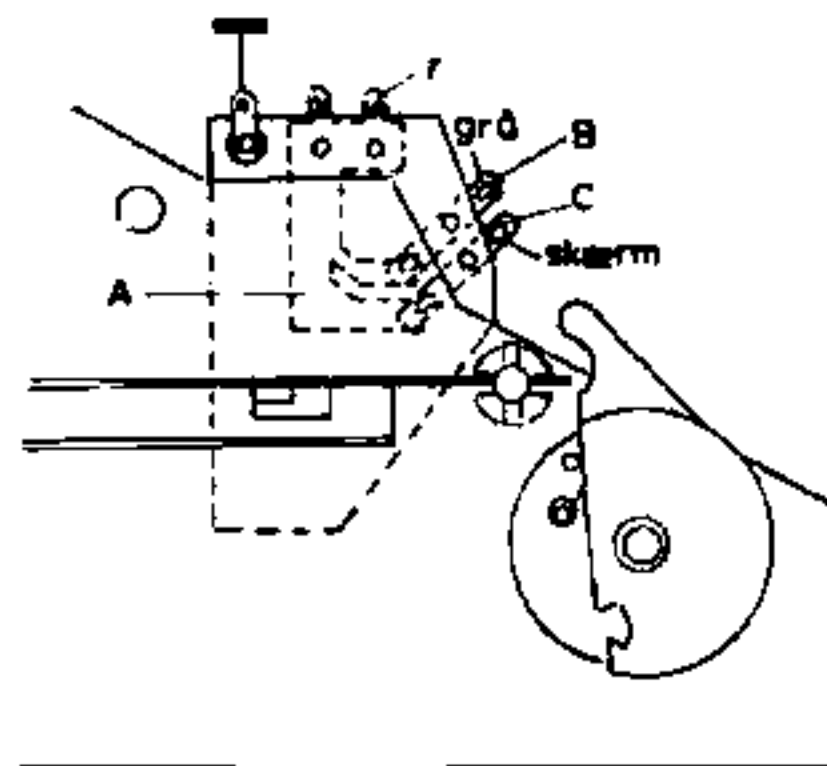

Adjust tags B and C so that on the pickup being raised contact will first be made between A and B (short-circuiting the channels together) and thereafter between A and C (Short-circuiting the signal).

NOTE: Both contact pairs should be open with the pickup lowered.

Relay

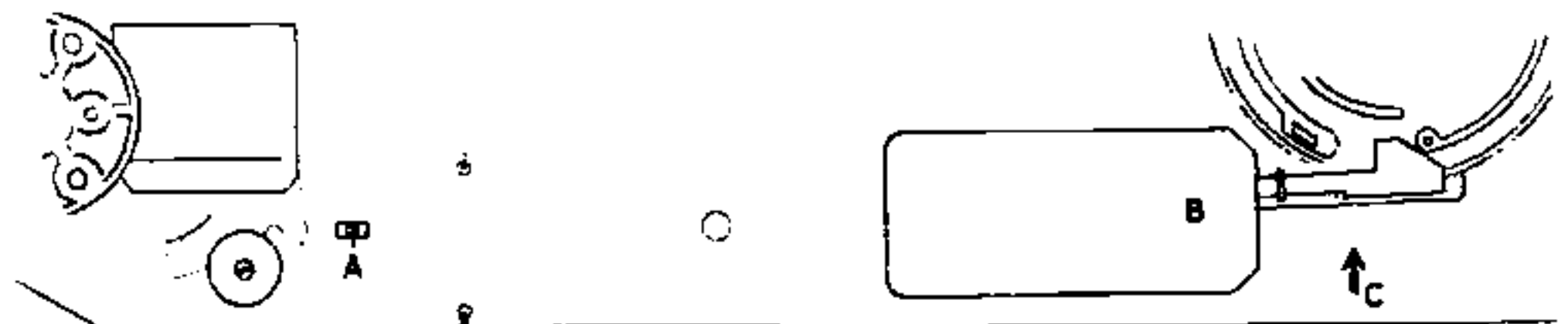

Adjust relay B as far as possible in the direction of arrow C but only to the point where the relay will positively attract the armature when the LIFT button is pressed quickly.

Adjustment is performed with eccentric A, which becomes accessible after removal of the turntable. Eccentric A should be secured with lacquer after adjustment.

Motor-voltage Switch

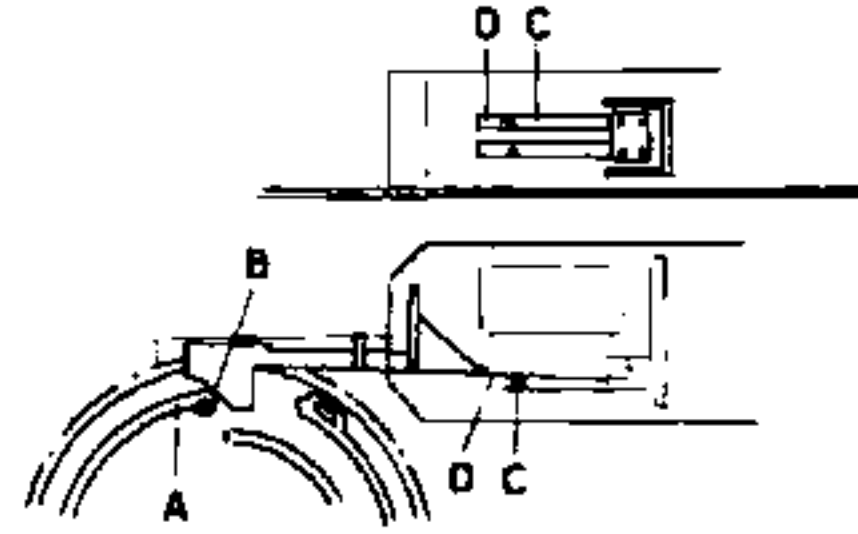

Adjust contact pair C to provide contact when arm B is halfway up on curve segment A when the cam-lifting wheel is rotated manually. Adjustment is performed by bending the tag D through the hole in the relay housing.

NOTE: The relay coil must not be energized while making this adjustment.

Switch for Relay Holding Voltage

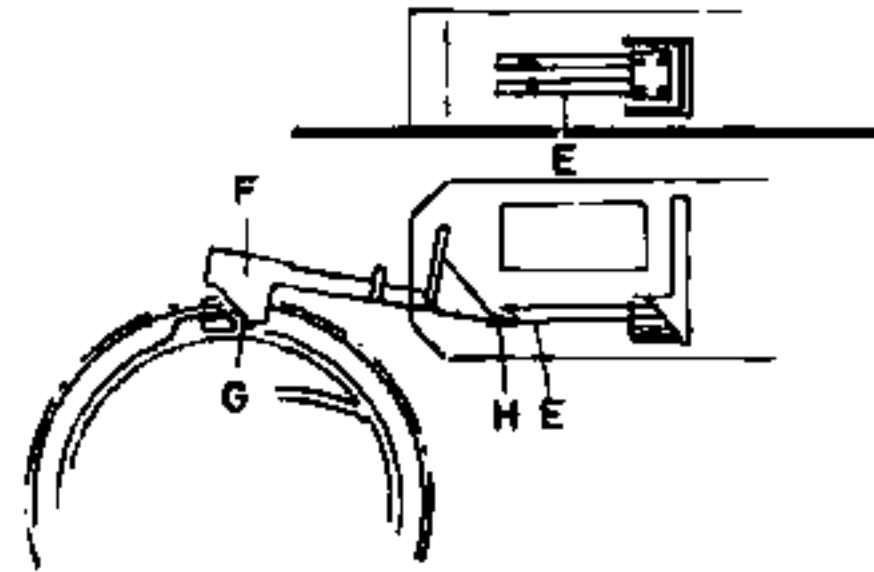

Adjust contact pair E so that relay holding voltage is switched off when arm F is halfway up on cam G.

Adjustment is performed by bending the tag H through the hole in the relay housing.

- Note:**
1. Both contact pairs of the relay should be open when the cam-lifting wheel is in its stop position and the relay is not simultaneously energized from "LIFT".
 2. Both contact pairs of the relay should make contact when the relay coil is energized (from "LIFT") and the cam-lifting wheel is simultaneously in its stop position (arm F in the neutral position).

Rotor

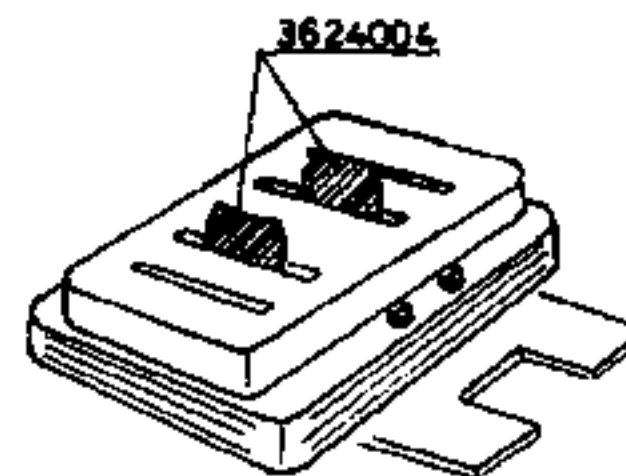

In case the motor has been disassembled it will be necessary to center the rotor. Centering is performed by means of two gauges, supplied together under No 3624004.

The gauges should be inserted from the bottom as shown by the sketch. Thereafter tighten the bolts.

Step-cone pulley

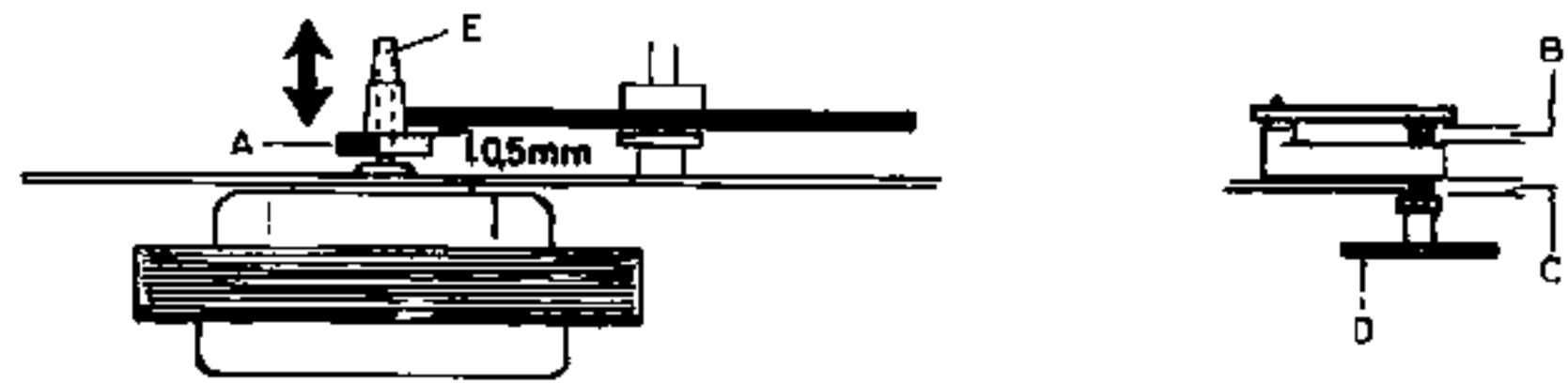

Set **record selector** at 17 (45 r.p.m.).
 Adjust **screw D** until distances **B** and **C** are equal.
 Slacken **screw A**.
 Set the **step-cone E** at the correct speed.
 Retighten **screw A**.

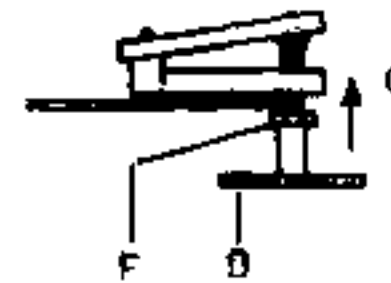

Turn **screw D** fully in the direction of **C** towards stop.
 If the **idler wheel** now rests against the collar of the step-cone pulley, slacken locknut **F**. It is now possible to adjust the position of screw **D** on the adjusting spindle and thus the position of the idler wheel on the step-cone pulley at maximum speed.
 Retighten locknut **F**.
 Check that turntable speed can be varied $\pm 3\%$ in relation to correct speed.

Centering the sub chassis

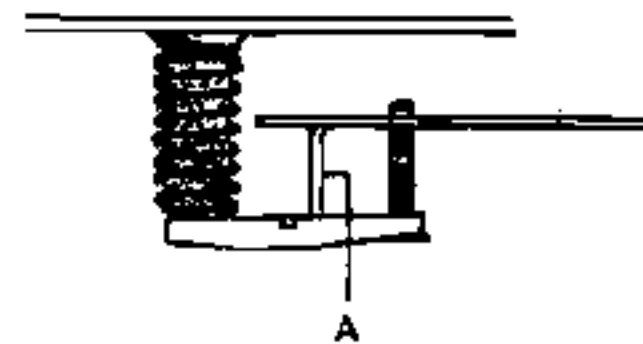

Turn the transport screws counter-clockwise towards stop. Bend leg **A** so that the distance between turntable and top panel is the same all the way round.

Height of sub chassis

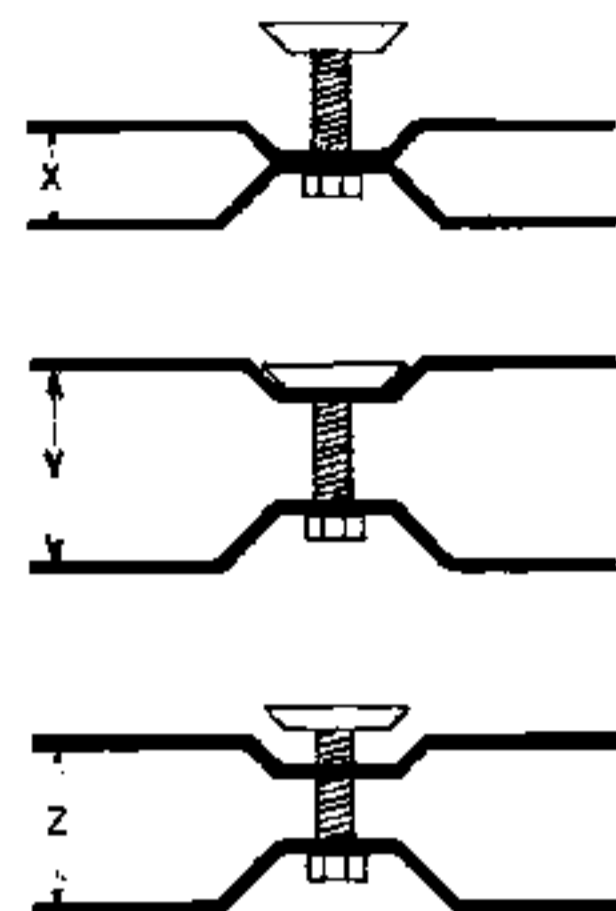
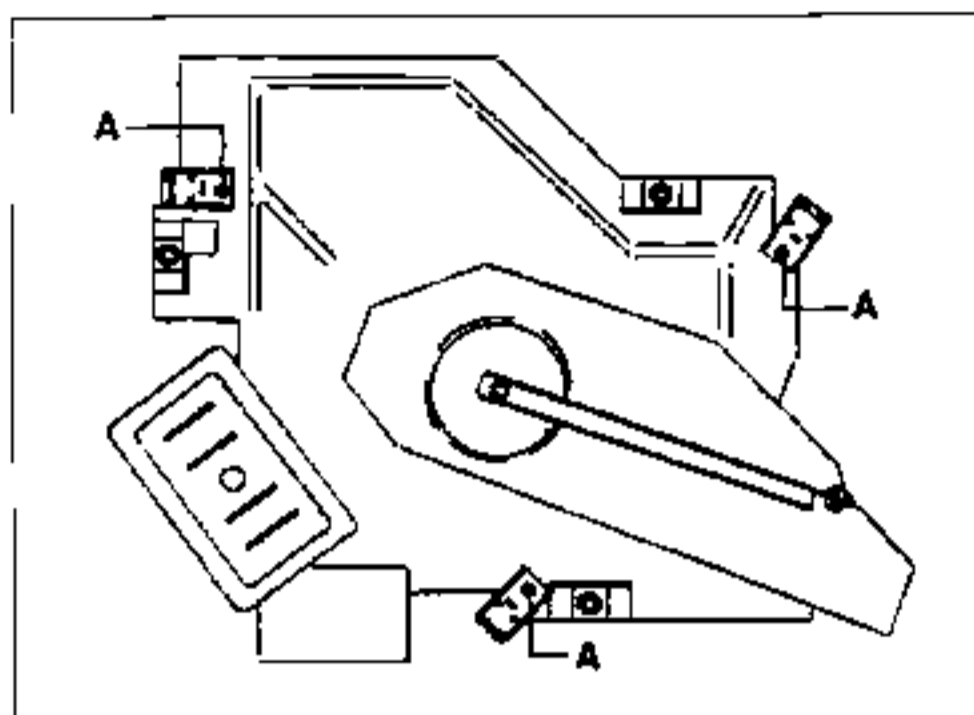

Turn the transport screws counter-clockwise towards stop.
 Push the sub chassis hard against the top cover and measure distance X (see drawing).
 Pull sub chassis as far away from top panel as possible and measure distance Y.
 Adjust the sub chassis by means of screws A (with a standard record weighing 75-100 g on the turntable) so that distance Z is equal to $(X + Y) : 2$.
 The height of the turntable in relation to the top cover should be uniform all the way around.
 Check that the subchassis moves freely.

Pickup, Height

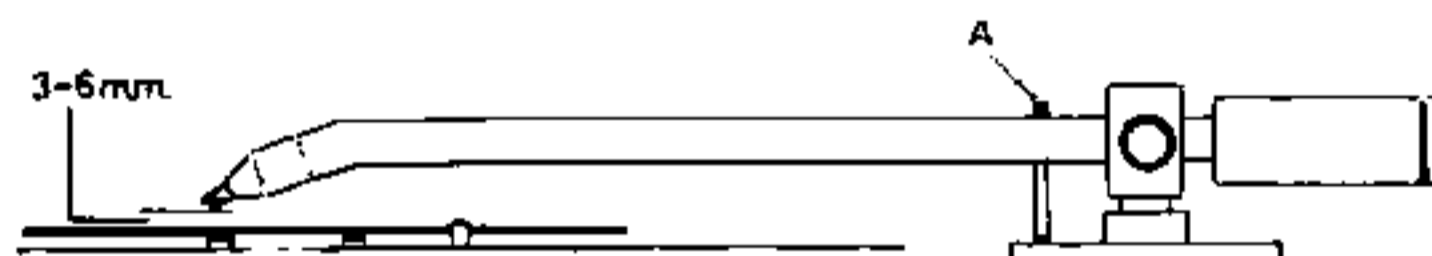

Lifting screw A is adjusted with the pickup arm raised and the pickup stylus floating between 3 and 6 mm above the turntable's outermost knobs (see sketch).

NOTE: When in the raised position, the pickup must not touch the record when slid in above the latter.

Pickup Arm, Balance

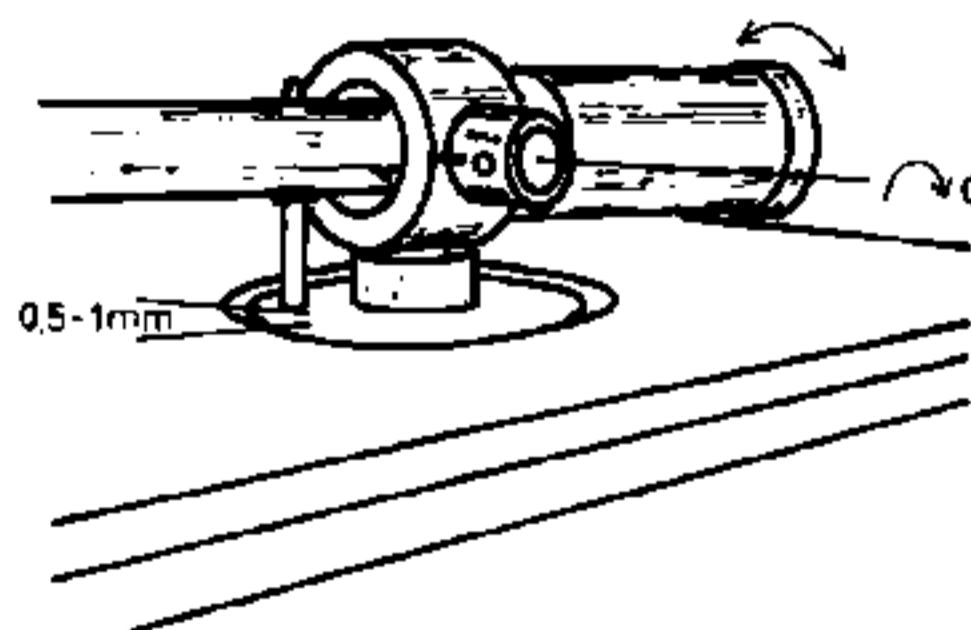

Turn the stylus-force adjustment screw to 0.

Adjust the counterbalance weight so that the pickup arm will be brought into balance with the lifting screw floating between 1/2 and 1 mm above the lifting ring.

Adjustment is performed by rotating the rear rim of the counterbalance weight.

Thereafter adjust stylus force.

Beogram 1203: 2 pond (SP 14 A)

Beogram 2000: 1,2 pond (SP 10 A).

Pickup Arm, Downstroke

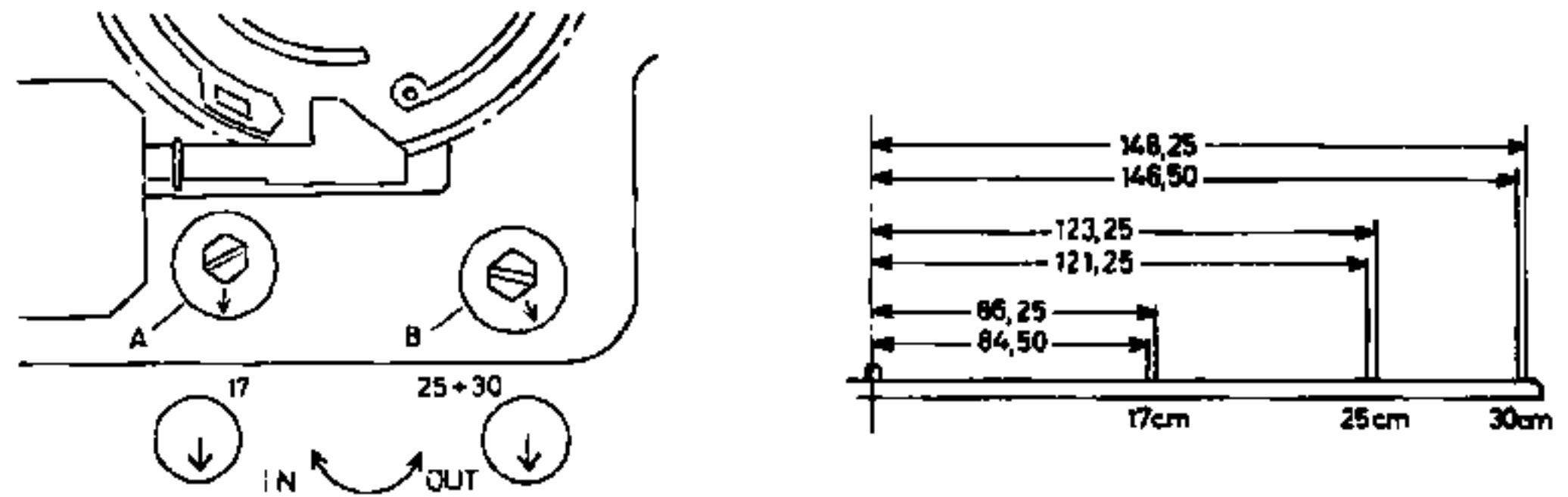

With the record selector at "17", adjust eccentric A so that the pickup when operated by the automatic cueing mechanism will lower into the field marked "17" on the sketch above.

Adjust eccentric B so that the pickup will lower in the field marked "30" with the record selector at "30" and in the field marked "25" with the record selector at "25".

NOTE: Dimensions are given from the centre of the record spindle.

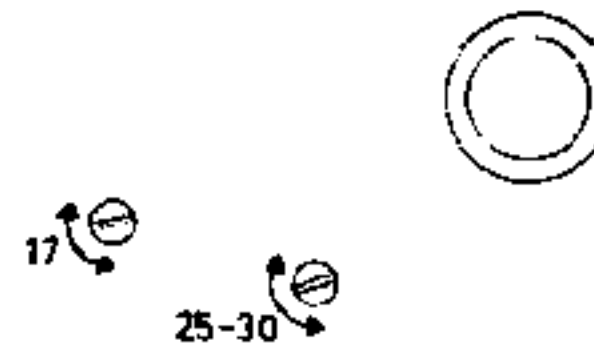

With the base-plate in position, lowering of the pick-up arm can be adjusted through the holes indicated in the base-plate.

Pickup, Parallelity



Loosen screw C.

Turn socket D so that the distances A and B are equal - in other words so that the plane portion of the pickup is parallel with the surface of the record.

Dust Cover, BEOGRAM 2000

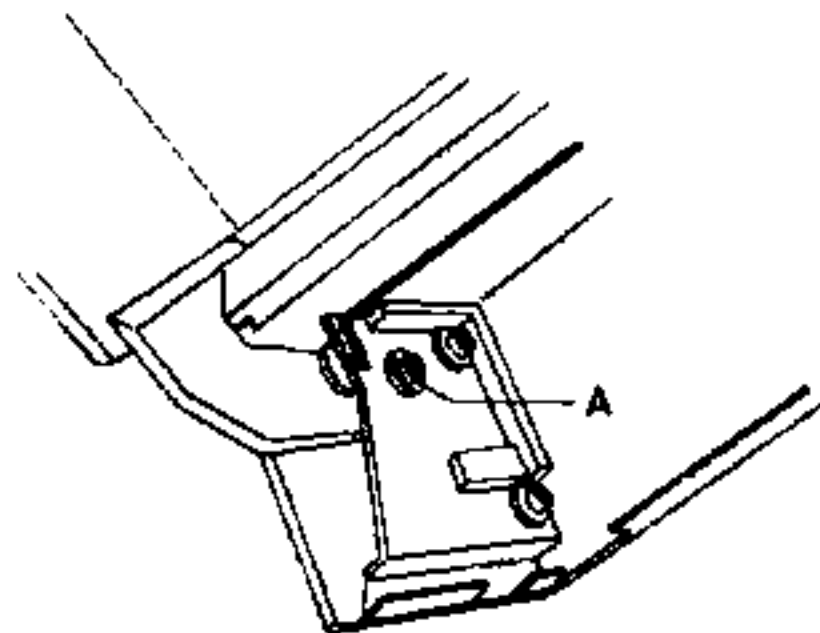

With the screw A in both sides of the cover housing adjust the friction so that the cover can hold itself in all positions within its travel.

**PARTS LIST FOR BEOGRAM 1203,
TYPE 5239**

1	3164076	Dust cover
2	3950283	Moulding
3	3411521	Cabinet, teak
	3411523	Cabinet, rosewood
	3411524	Cabinet, oak
	3411525	Cabinet, white
4	2628003	Spring
5	2576071	Spacer
6	2510067	Lead holder
7	2013208	Screw 2,84 x 9,52 mm ART 4261
8	3454156	Cabinetbottom
9	2042247	Screw AM 4 x 30 mm din 84, black

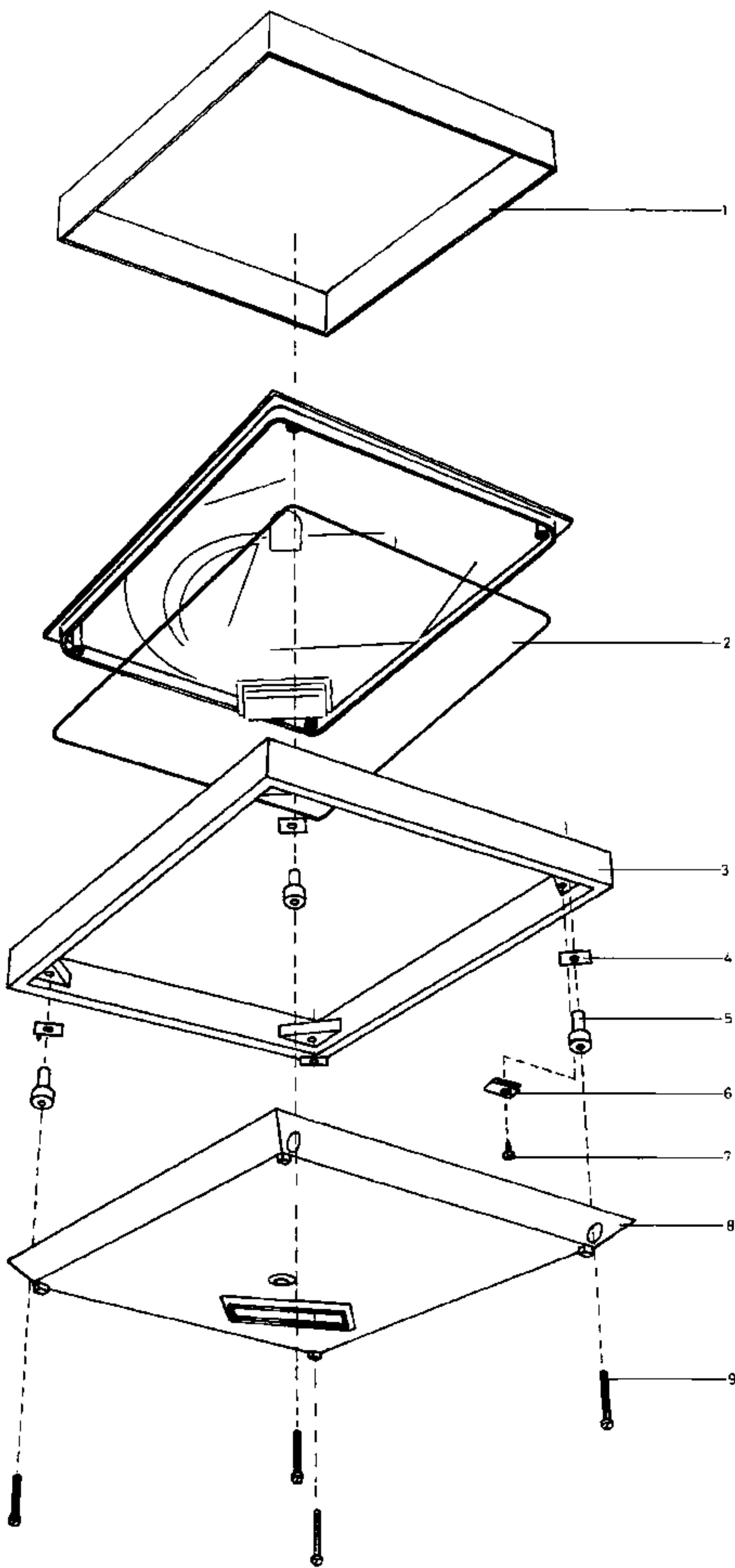

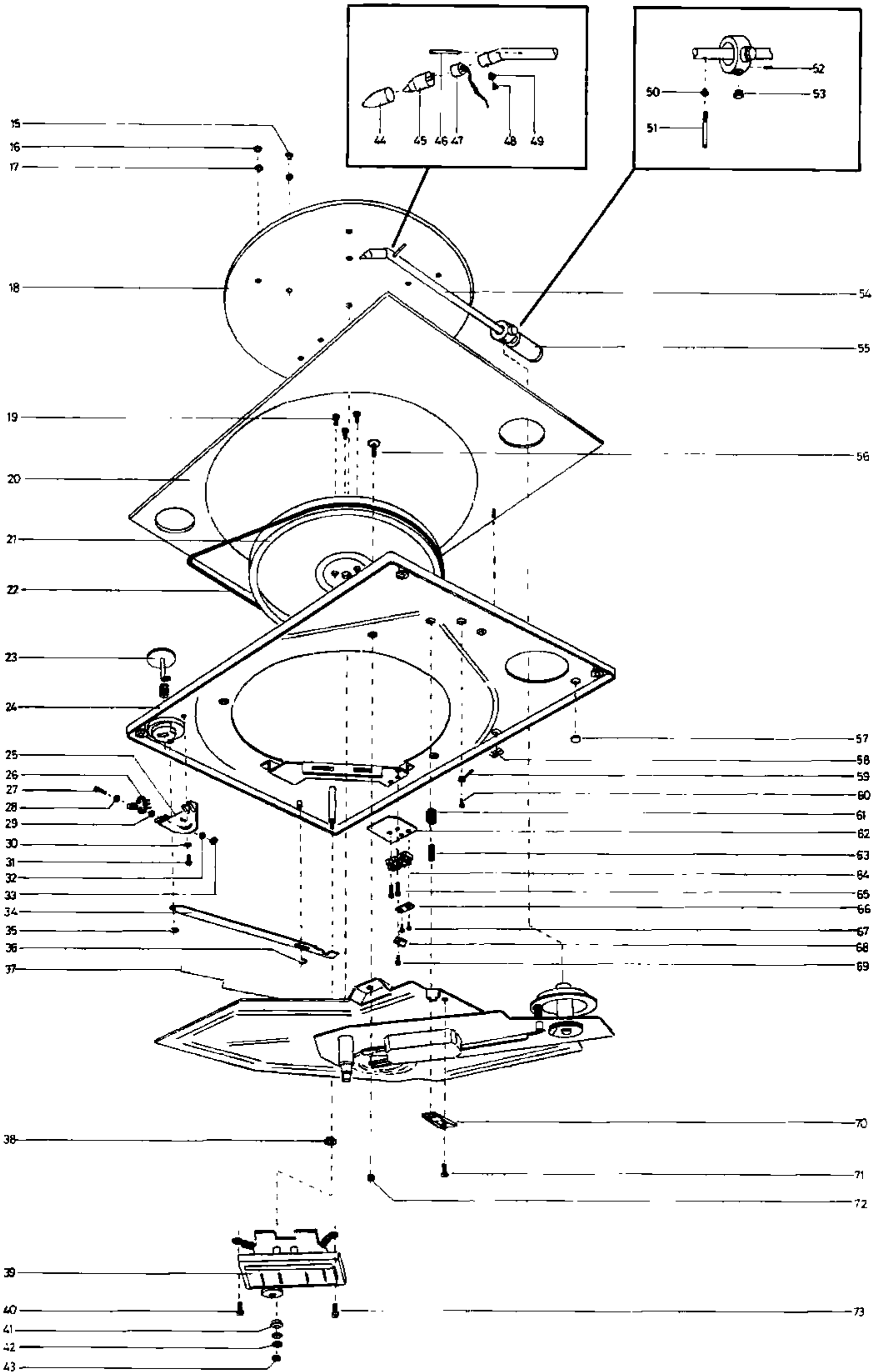

15	2574055	Support for plate, short
16	2574056	Support for plate, long
17	2622188	Washer
18	2726076	Turntable
	2620054	Felt
19	2042205	Screw AM 4 x 6 mm din 84
20	3458110	Top plate
21	2726062	Turntable
22	2732030	Belt
23	2775222	Knob
	2812035	Spring for knob
24	3112161	Chassis
	2390045	Locking ring
	2620044	Washer
	2770141	Knob
	2816073	Spring
	2917013	Ball
25	3152067	Holder
26	7402081	Microswitch
27	2038220	Screw AM 3 x 12 mm din 84
28	2622041	Washer
29	2622041	Washer
30	2622041	Washer
31	2038206	Screw AM 3 x 4 mm din 84
32	2622016	Washer
33	2380011	Nut M3
34	2570018	Arm
35	2390002	Locking ring
36	2390006	Seeger circlip
37	2570020	Arm
38	2938075	Transit protection device
39	8400050	Motor 50 Hz
	2755007	Gear
40	2042205	Screw AM 4 x 6 mm din 84
41	2938076	Transit protection device
42	2622024	Washer
43	2380016	Nut M4
44	3302086	Cap for pick-up
45	8905432	Pick-up cartridge SP 14 A
	8905435	Stylus assembly for SP 14 A
46	2992028	Finger grip
47	6270055	Socket
48	2085002	Screw
49	2938089	Bushing
50	2938072	Bushing
51	2574070	Lifting screw
52	2072916	Threaded pin
53	2365084	Bushing
54	2850061	Pick-up arm, complete
55	3342021	Counterweight
56	2044924	Transit protection device
57	2622221	Washer
58	2395019	Spire
59	7530023	Solder tag
60	2015909	Screw 3,5 x 6,35 mm
61	2812055	Spring, suspension 8 turns
	2812060	Spring, suspension 9 turns
	2812058	Spring, suspension 6 turns
62	3170128	Insulating piece
63	3333007	Foam rubber
64	7505005	Connection block
	4010050	Capacitor 10 nF/265 V
65	2038220	Screw AM 3 x 12 mm din 84
66	0287155	Clamp
67	2013208	Screw 2,84 x 9,52 mm ART 4261
68	2510067	Attachment for mains lead
69	2038005	Screw AM 3 x 5 mm din 84
70	2542282	Suspension bracket
71	2042004	Screw AM 4 x 15 mm din 963
72	2380021	Nut M4
73	2042205	Screw AM 4 x 6 mm din 84

80	2834011	Turntable hub
81	2038220	Screw AM 3 x 12 mm din 84
82	3150009	Bearing bushing
83	2380013	Nut M3
84	2700010	Gear-wheel
85	2361019	Locking pin
86	2854031	Arm
87	2819073	Spring
88	7600018	Relay
	4200279	Elko 1 μ F/250 V
	8300176	Diode
89	3131068	Cover
90	2854032	Arm
91	3131067	Cover
92	2819074	Spring
93	3014025	Friction plate
94	2819075	Spring
95	2395030	Lock disc
96	2938084	Washer 25-30 cm
	2938088	Washer 17 cm
97	3014024	Arm positioning guide
98*	3014026	Arm positioning guide
99	2390002	Circlip
100	2622200	Washer
101	2905052	Adjustment bearing
102	3035020	Plastic foot
103	2622198	Washer
104	2850057	Cueing arm
105	2803005	Eccentric
106	2992048	Pin
107	7600026	Relay
	3947469	High-voltage insulating tape
108	2819076	Holder
109	3017010	Cam-lifting wheel
110	2390050	Circlip
111	2510004	Cable clamp
112	2015200	Screw 3,5 x 6,35 mm ART 426 1
113	2012903	Screw
	2625002	Tooth-lock washer
114	2622198	Washer
115	2622198	Washer
116	7459004	Switch contacts
117	2854033	Arm
118	2389039	Nut
119	2812063	Spring
120	3130054	Lifting device
121	2038005	Screw AM 3 x 5 mm din 963
122	2802025	Lifting ring
123	2390052	Circlip
124	2622199	Washer
125	3152105	Ball holder
126	2917015	Ball
127	2938067	Ball guide
128	2938068	Cage
129	2938085	Pick-up bearing
130	2390032	Bearing lock
131	2390065	Circlip
132	3110002	Chassis
	3112149	Middle chassis
133	2390054	Circlip
134	2851067	Coupling
135	2819106	Spring
136	2750012	Clutch disc
137	2819107	Spring
138	2938086	Bearing column
139	2938103	Adjustment collar
140	2850076	Lifting bar
141	2852025	Lifting arm
142	2938087	Pick-up bearing, complete

* Pos. 98: After No. 195800, 3014031 is used

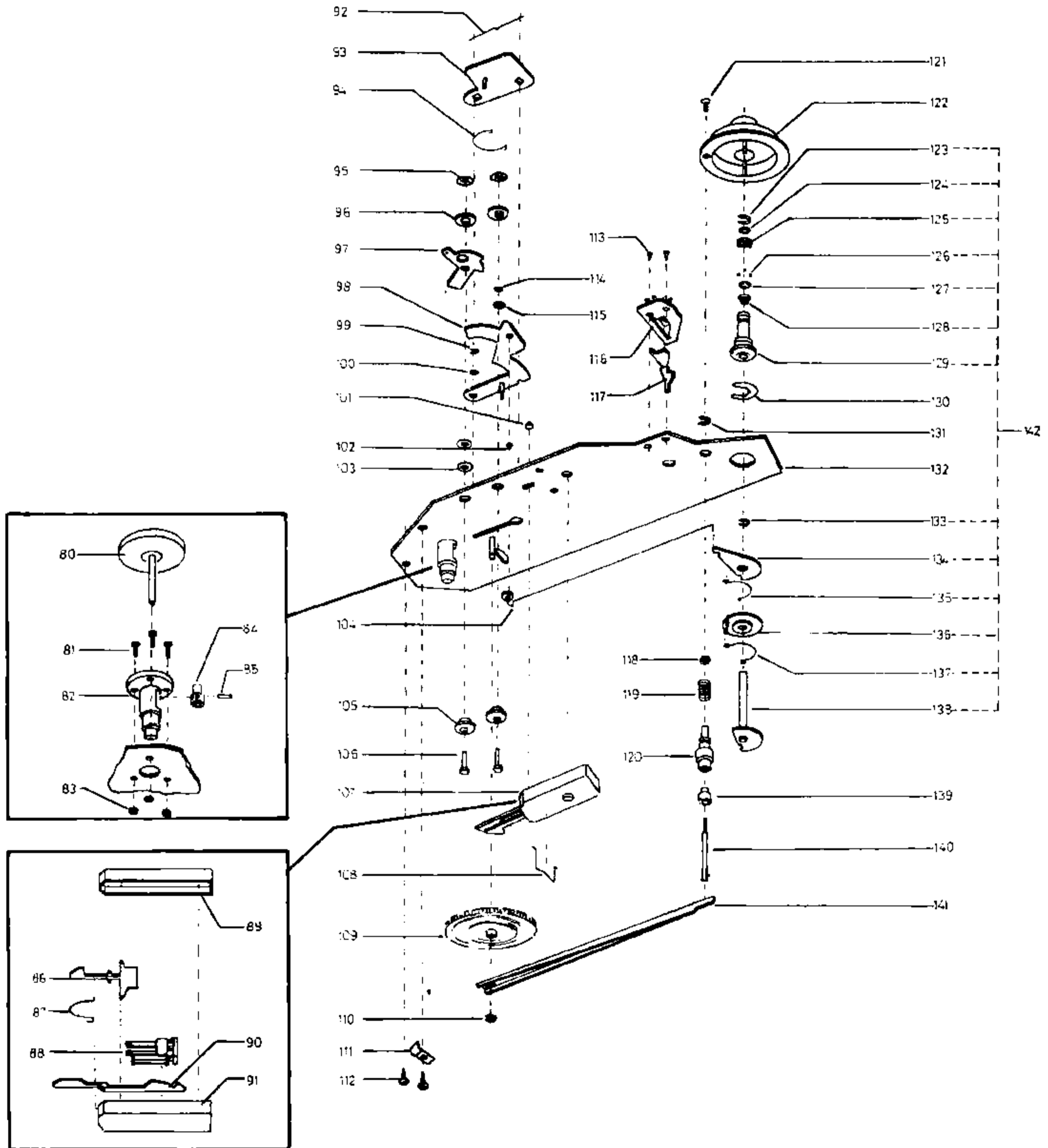

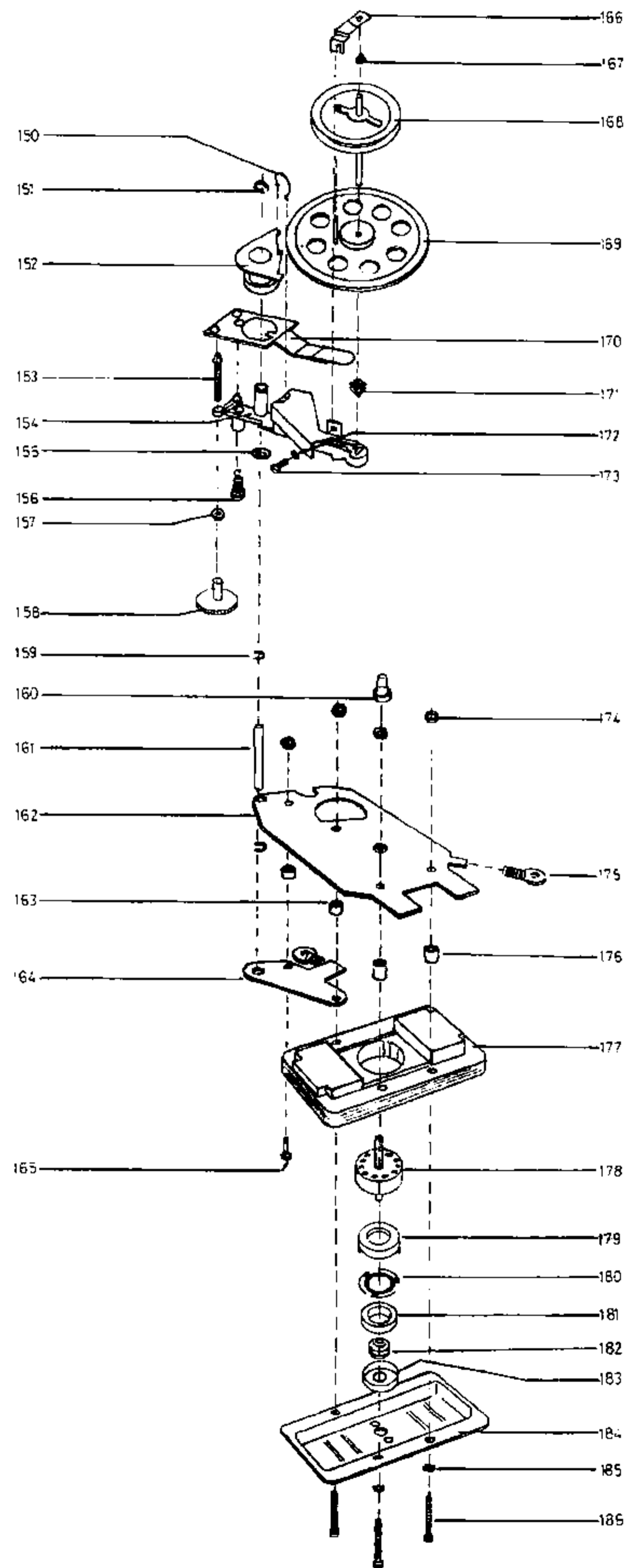

150	2816068	Spring
151	2390015	Circlip
152	3017006	Lifting arm
153	2076703	Vernier speed regulator screw
154	3112099	Gear chassis
155	2622198	Washer
156	2810034	Spring
157	2380012	Nut M3
158	2932040	Adjustment knob
159	2390050	Circlip
160	2804033	Stepped pulley
	2070001	Screw
161	2831020	Shaft
162	3110003	Chassis with bearing
163	2576054	Spacer
164	3110004	Motor bracket
165	2038222	Screw AM 3 x 14 mm din 84
166	3150011	Bearing holder
167	2905032	Bearing
168	2722004	Drive wheel
169	2804012	Idler wheel
170	2854019	Lifting arm
171	2905032	Bearing
172	2622159	Washer
173	2038205	Screw AM 3 x 4 mm din 84
174	2380012	Nut M3
175	2934060	Suspension
176	2576055	Spacer
177	3351002	Stator
178	2871001	Rotor
179	3150015	Race
180	2819055	Spring
181	3912033	Felt washer
182	2905036	Bearing
183	2905059	Bottom bearing
184	3164105	Cover
185	2625002	Tooth-lock washer
186	2038235	Screw AM 3 x 25 mm din 84

PARTS NOT SHOWN

3015002	Record spindle
6270138	Pick-up cable with plug
6271047	Mains lead with plug
3535035	Instruction diagram
33971371	Outer carton
3391319	Top/bottom inserts
3397148	Packing, bottom
3397149	Packing, lid
3397151	Packing, top
3917023	Foam rubber support for pick-up arm
3984208	Oil for bearings in Beogram motor

**PARTS LIST FOR BEOGRAM 2000,
TYPE 5240**

1	3164201	Tiltable dust cover, complete
8	3454163	Cabinet bottom, complete
20	3458120	Top plate
45	8905425	Pick-up unit SP 10 A
	8905429	Stylus unit SP 10 A
190	3164102	Dust cover
191	2623020	Friction disc
192	3031052	Mounting hardware, left
	3031053	Mounting hardware, right
193	2013008	Screw
194	2389032	Screw
195	2932049	Bushing
196	2389032	Screw
197	3152091	Spring retainer
198	2819053	Spring, left
	2819054	Spring, right
199	2568203	Trim strip

PARTS NOT SHOWN

3010007 Stop for cover

Other parts as in BEOGRAM 1203, type 5239

CABINET BEOGRAM 2000

The cabinet for Beogram 2000 is delivered without holes for stops. The holes are drilled as shown on the drawing which shows the right front corner from above. Corresponding hole is drilled in the opposite cabinet side.

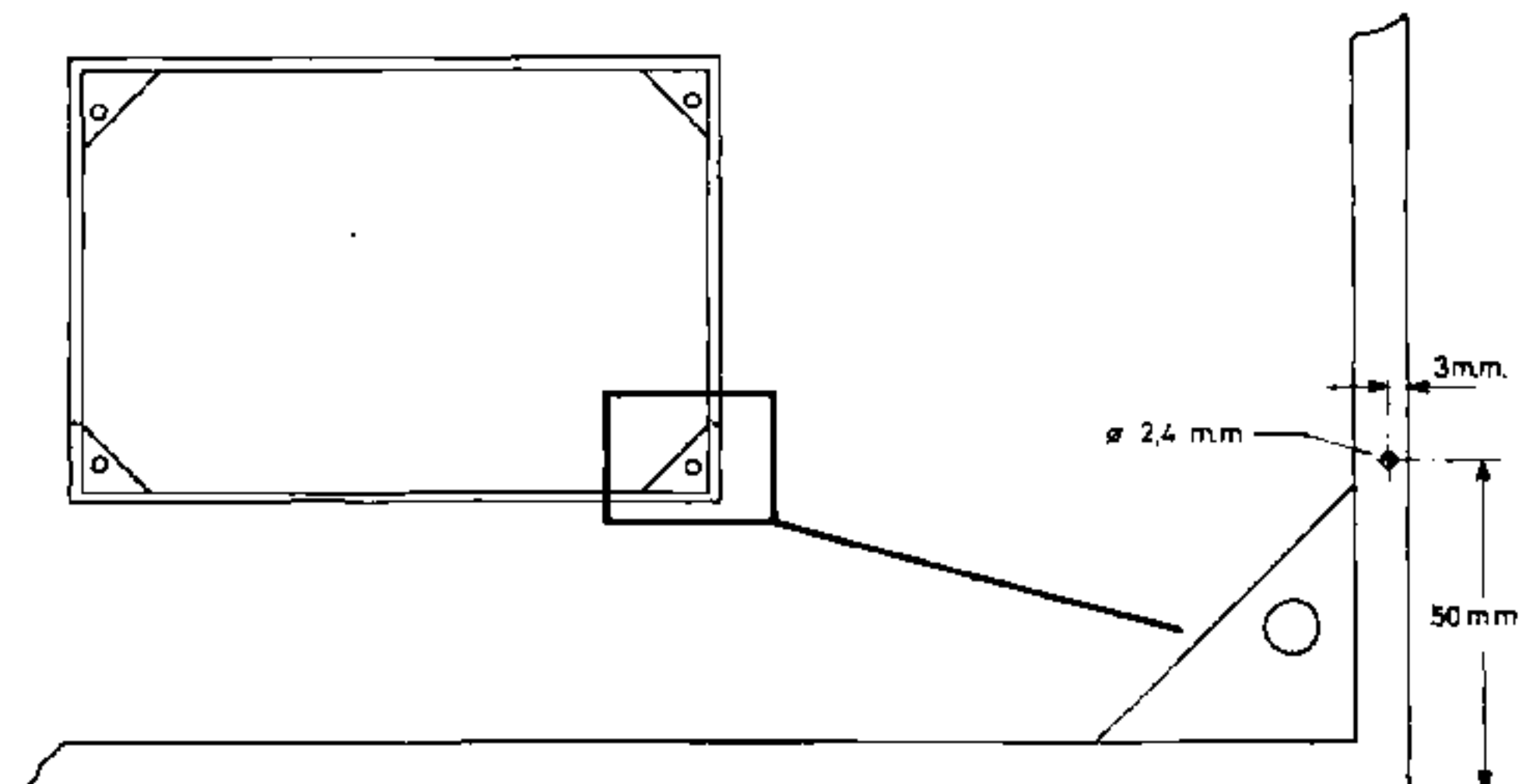

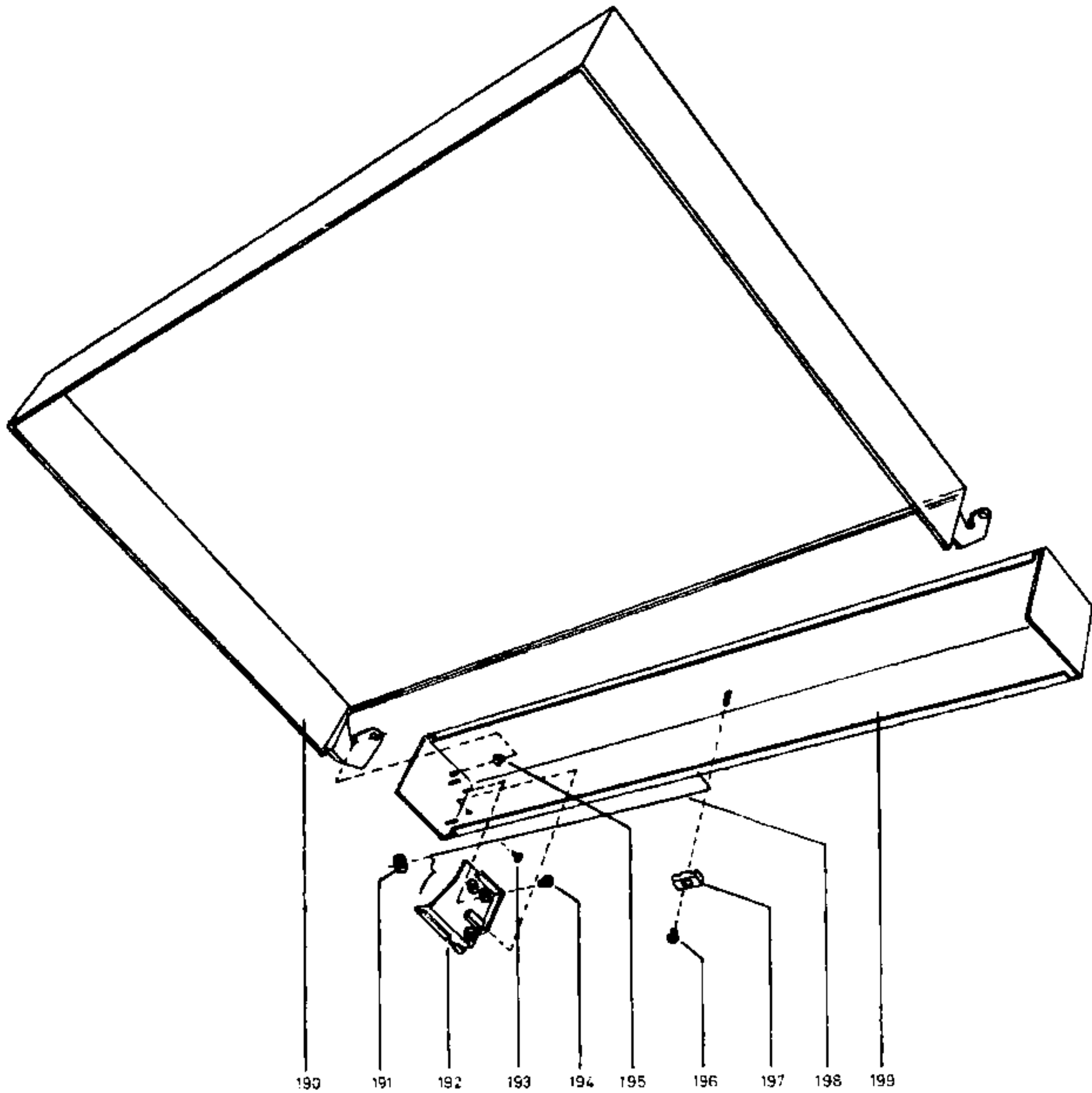

MODIFICATION

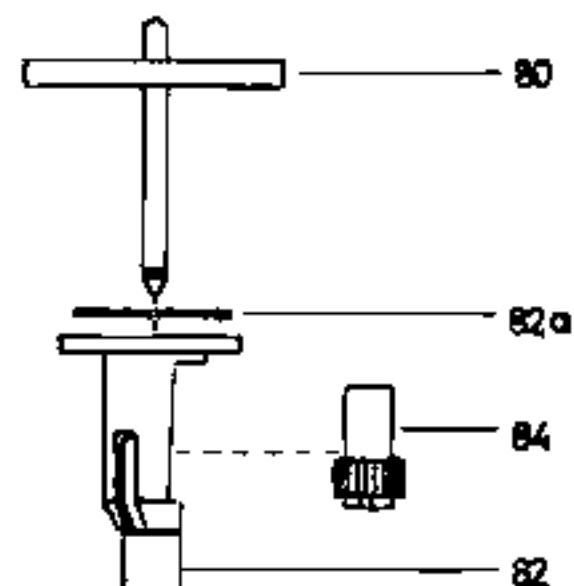

80	2834044	Turntable hub
82	3150037	Bearing bushing
82a	2905060	Bearing (top)
84	2700014	Gear-wheel

**BANG & OLUFSEN A/S
DK - 7800 STRUER
DENMARK**

**TELEPHONE 07 - 85 11 22 TELE X 66529
CABLE ADDRESS BANGOLUF**

3538224

d.kr. 7,50

**PRINTED IN DENMARK
I/S EKSPRES-TRYKKERIET STRUER 9074**

Form. 7184