

ALBA 90 THREE-BAND PRESTO-TUNE

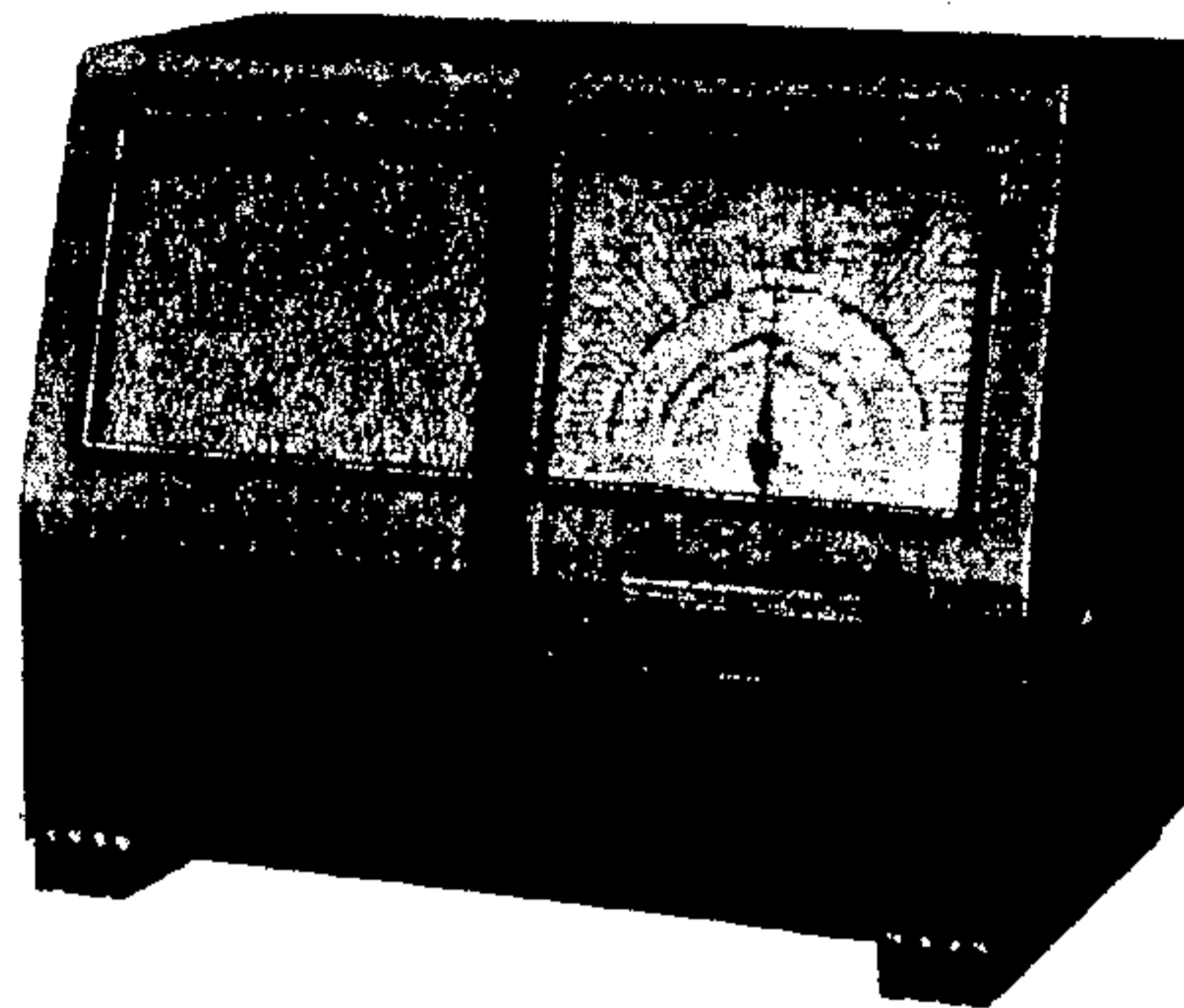

Push-button tuning of six stations by a mechanical system is a feature of the model 90 by A. J. Balcombe, Ltd.

CIRCUIT.—A triode hexode frequency changer, which may be either a Mullard TH4A or TH4B, is the first valve. On the short waves coupled circuits are used for the input, the tuned winding being returned to the earth line so that there is no A.V.C.

On the medium and long waves a single primary winding is coupled to the tuned circuits, and these have iron cores, A.V.C. being supplied in the normal manner. The oscillator section is arranged for tuned grid working.

Trimmer-tuned I.F. transformers are used, the first coupling the anode circuit of V1 to the input of V2, an H.F. pentode supplied with A.V.C. through a separate decoupling network. This valve also amplifies the gramophone pick-up output, for which purpose there is a resistance load in the anode circuit in addition to the primary winding of the second I.F. transformer.

V3 is a double diode pentode connected

in a perfectly standard manner to give delayed A.V.C. and demodulation. The grid input for the pentode section is taken from the volume control, which is fed either from the demodulator load or from the anode load of V2 when the latter valve is used as an L.F. amplifier with a pick-up.

Tone control is effected by a fixed condenser and variable resistance across the anode load of V3, which, of course, is the speaker transformer primary.

Power supply is by means of the usual mains transformer and full-wave rectifier valve, V4, utilising the field winding of the speaker for smoothing, in conjunction with two electrolytic condensers.

Chassis Removal.—Some care is necessary in removing the chassis from the

cabinet. The control knobs are released by grub-screws, and the push-buttons are pulled off their operating shafts where they are held by spring contacts.

The special press-button locking-shaft must also be removed, and this is done by completely unscrewing and withdrawing the locking-sleeve from the side of the cabinet. It will be noted that this operation immediately turns the condenser to minimum, after which some appreciable force is necessary to unscrew the locking-sleeve.

After releasing the four retaining bolts the chassis can be withdrawn quite easily. There is sufficient slack on the speaker

(Continued on page 18.)

RESISTANCES

R.	Purpose.	Ohms.
1	V1 A.V.C. decoupling ..	250,000
2	V1 screen decoupling ..	25,000
3	V1 cathode bias ..	100
4	V1 osc. grid leak ..	50,000
5	S.W. regeneration control ..	200
6	V1 osc. anode load ..	25,000
7	V2 A.V.C. decoupling ..	500,000
8	V2 cathode bias ..	150
9	H.F. filter ..	50,000
10	Demodulating diode load ..	500,000
11	Volume control ..	500,000
12	V3 cathode bias ..	150
13	A.V.C. diode load (part) ..	250,000
14	A.V.C. diode load (part) ..	500,000
15	V2 A.F. anode load ..	5,000
16	Tone control ..	50,000
17	Pick-up shunt ..	250,000

CONDENSERS

C.	Purpose.	Mfds.
1	M.W. and L.W. aerial coupling ..	.0002
2	M.W. and L.W. top coupling ..	.000005
3	V1 A.V.C. decoupling ..	.05
4	V1 screen decoupling ..	.1
5	V1 cathode bias shunt ..	.1
6	V1 osc. grid ..	.0001
7	S.W. fixed padder ..	.01
10	V1 osc. anode coupling ..	.1
11	V2 A.V.C. decoupling ..	.05
12	V2 cathode bias shunt ..	.1
18	H.F. filter ..	.0001
14	L.F. coupling ..	.005
15	H.F. filter ..	.0001
16	A.V.C. coupling ..	.0002
17	Pentode compensator ..	.005
18	V3 cathode bias shunt ..	25
19	H.T. smoothing ..	12
20	H.T. smoothing ..	8
21	V2 anode H.F. bypass ..	.002
22	V2 L.F. coupling ..	.005
23	Tone control ..	.05
24	Mains filter ..	.0001
25	H.T. shunt ..	.1

QUICK TESTS

Quick tests can be made on this receiver between the chassis and the tags on the speaker strip. The voltages are as follows:—
 Chassis and blue, 325 v., unsmoothed H.T.
 Chassis and red, 260 v., smoothed H.T.
 Chassis and black, 230 v., V3 anode.

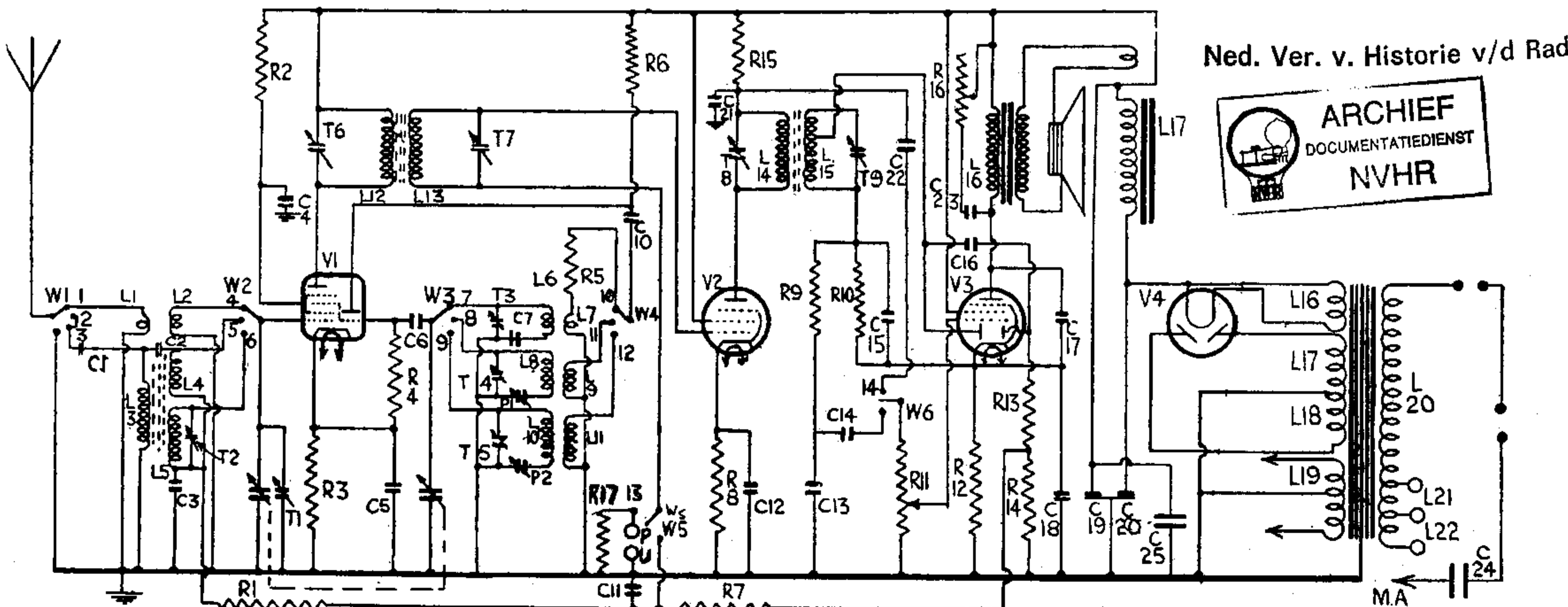

A conventional "short" superhet circuit is found in the model 90. The automatic tuning, being solely mechanical, does not involve any special circuit features.

How to Adjust the Push Buttons

THE push-buttons control the setting of the ganged condenser. The mechanical unit used consists of a pair of racks connected to each button. When a button is pressed, the racks cause two pinions to rotate in opposite directions. These control a third stop member. An explanation of this type of unit has already been published in *Service Engineer*.

The method of adjustment is as follows: First of all slacken the locking sleeve, which is controlled by a large screw in a recess at the side of the cabinet. The screw is tight, and on releasing it the gang automatically turns to the minimum position.

There is no need to release the locking sleeve fully, and its freedom can be determined simply by depressing the various

knobs and making sure that they have no effect on the rotor.

The set is then tuned accurately by hand to a desired station, and the button on which this is to appear is fully depressed. The process is repeated with the other stations. No attempt must be made to adjust the locking sleeve until all the stations have been tuned in and the buttons pressed.

When the sleeve has been screwed up tightly it will be found that subsequent operation of the press-buttons will turn the condenser to the points to which it was previously adjusted by hand.

In adjusting the buttons it is advisable to make sure that when a button is fully depressed the station is accurately tuned in.

WINDINGS (D.C. RESISTANCES)

L	Ohms.	Range.	Where measured.
1	Very low	S.W.	Aerial and chassis.
2	Very low	S.W.	V1 grid and chassis.
3	55	M.W.	C1+C2 and chassis.
4	1.75	M.W.	V1 grid and C3+R1.
5	14	L.W.	V1 grid and C3+R1.
6	Very low	S.W.	W3 and C7.
7	200	S.W.	L7 and chassis.
8	.3	M.W.	W3 and P1.
9	28	M.W.	W4 and chassis.
10	9	L.W.	W3 and P2.
11	50	L.W.	W4 and chassis.
12	3	—	V1 anode and positive H.T.
13	3	—	V2 grid and W5.
14	3	—	V2 anode and C21+R15.
15	—	—	Demodulating diode and C15+R10.
16	480	—	On speaker tags.
17	1,000	—	On speaker tags.
18	28	—	Mains plug.

VALVE READINGS

No signal. Volume maximum. M.W. band.
200 volt. A.C. mains.

V.	Type.	Electrode.	Volts.	Ma.
1	(All Mullard) TH4B ..	Anode ..	250	2.7
		Screen ..	180	4.7
		Osc.anode	100	6.5
2	VP4B ..	Anode ..	200	11
		Screen ..	260	3.8
3	Pen. 4 DD ..	Anode ..	230	32
		Screen ..	280	6
4	DW4/350 ..	Heater	—	—
Pilot	Osram			
Fm's	M.E.S.	Filament	6.2	300

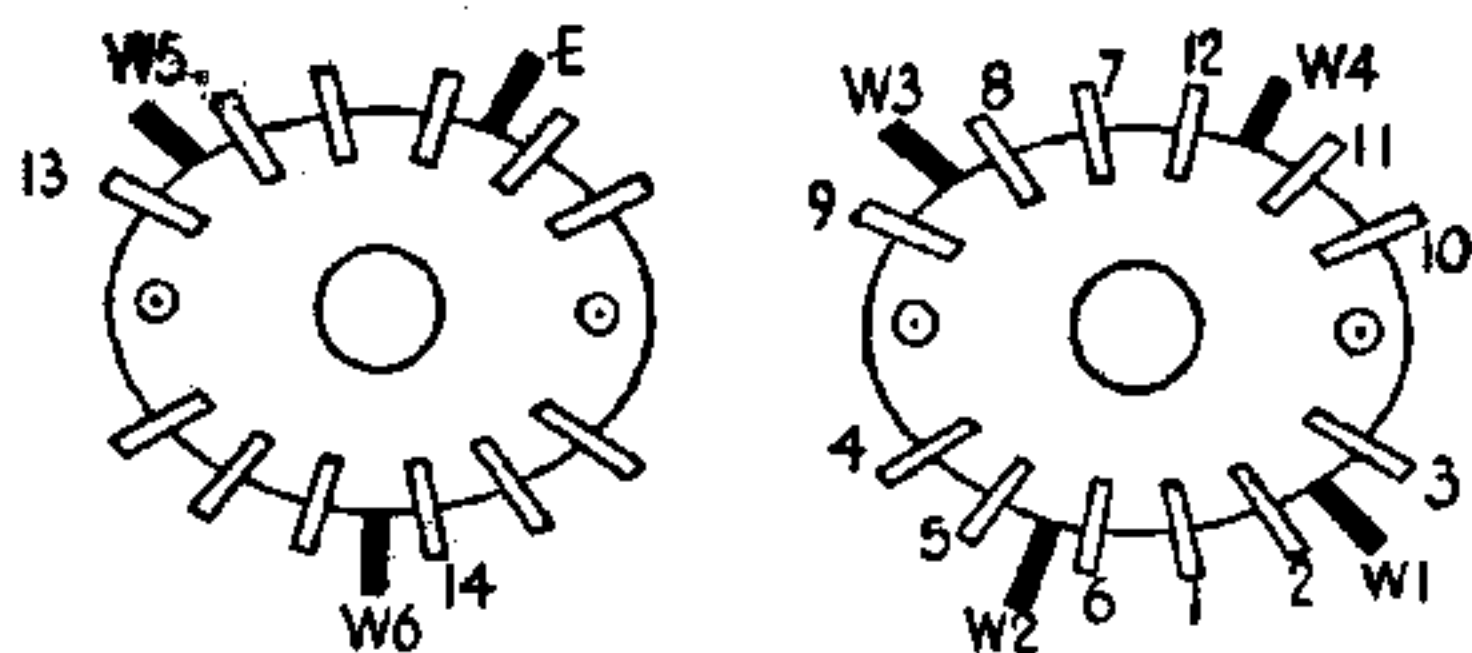

Left, the two switch banks with the one nearer the chassis on the left. See also "Switch Notes" on page 18.

Alba 90 on Test

MODEL 90.—For A.C. mains operation, 200-250 volts, 50-100 cycles. Price, 10 gns.

DESCRIPTION.—Three-valve, plus rectifier, three-band automatic and manual superhet.

FEATURES.—Large full-vision scale with concentric semi-circular calibrations in wavelengths and names on all bands, illuminated by pilot lamps. Mechanically adjusted tuning condenser for press-button working. Controls for manual tuning, volume, wave selection and tone. Sockets for aerial and earth, mains aerial and pick-up. Terminals on speaker for extension unit.

LOADING.—70 watts.

Sensitivity and Selectivity

SHORT WAVES (16.5-50 metres).—Very good gain and selectivity, with no drift trouble and easy handling.

MEDIUM WAVES (200-550 metres).—Excellent gain and adequate selectivity, with a reasonably quiet background and small local station spread.

LONG WAVES (900-2,000 metres).—Very good gain and selectivity, with only slight interference on Deutschlandsender.

Acoustic Output

Ample volume for an ordinary room, with crisp, clean attack and good high note radiation. Speech is very pleasing and orchestral music is well balanced on the medium and lower registers. Tone control is vigorous in action.

TWO exact replacement condensers are available from A. H. Hunt, Ltd., Garratt Lane, Wandsworth, London, S.W.18. For the block containing C's 19 and 20 there is unit 1,128, 7s. 6d., and for C18, 2,918. 1s. 9d.

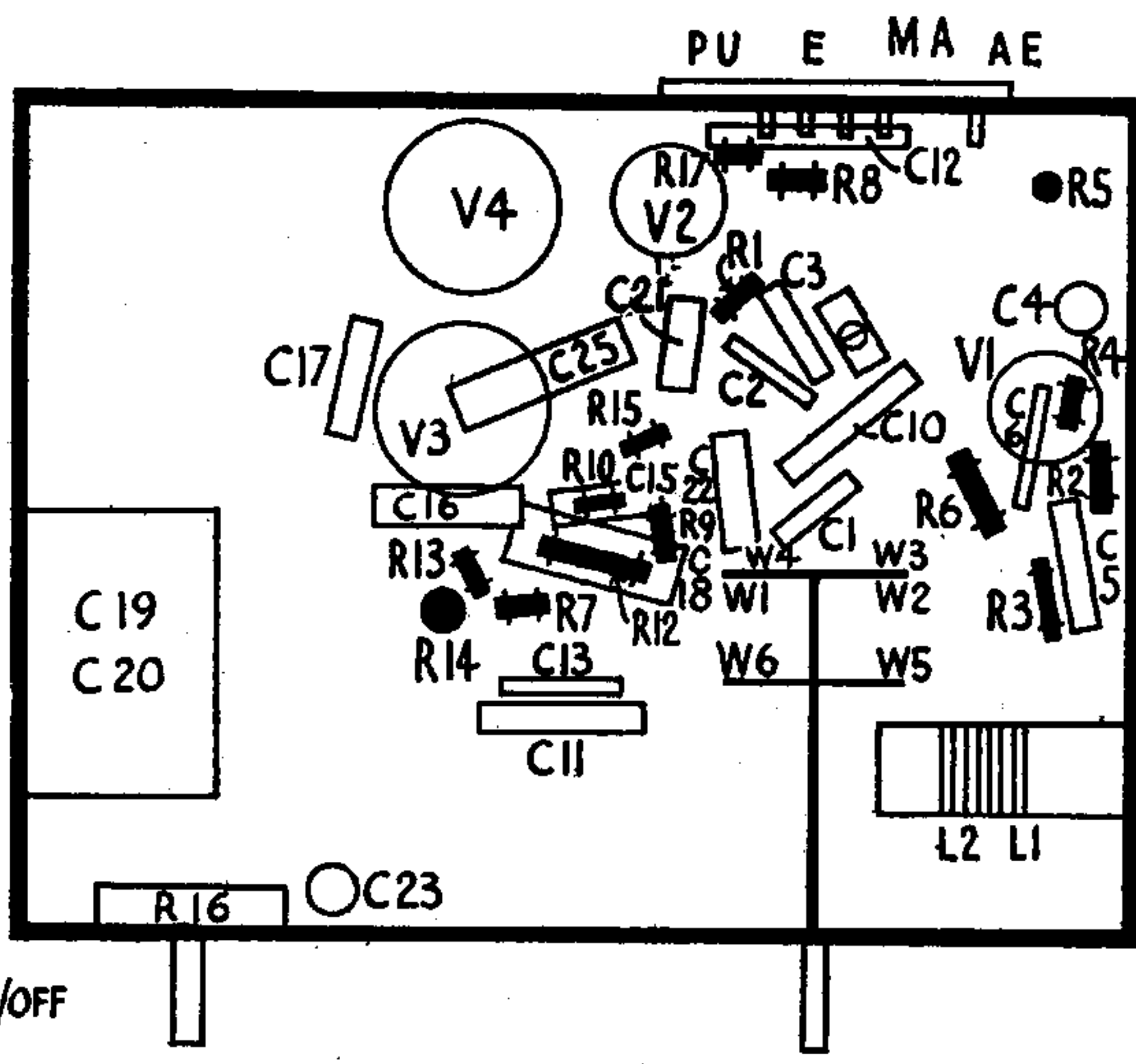
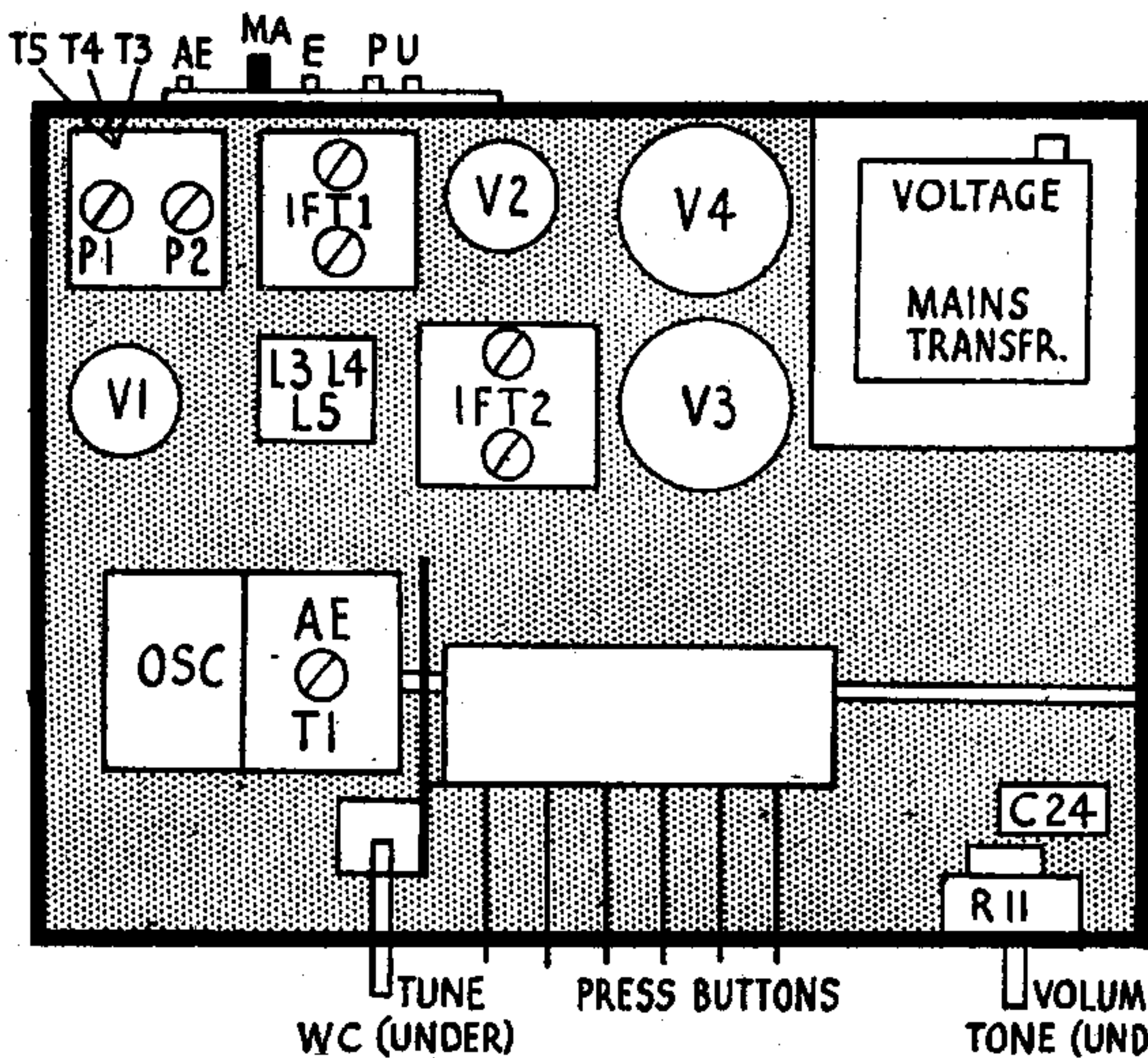

These two layout diagrams identify all the components on top (left) and underneath the Alba chassis.

Alba Model 90

(Continued from page 54.)

leads to enable most small adjustments to be carried out without removing the speaker. The speaker is, however, easily detached by releasing the four retaining nuts.

If the leads are unsoldered from the speaker strip the colours for reconnection are as follows: The frame of the speaker is white, unsmoothed H.T. blue, smoothed H.T. red, output anode black.

Special Notes.—In some chassis a .1 mfd. condenser is connected across the H.T. This is shown in the model we examined as C25, but it may be missing in certain receivers. In the model examined, R1 (V1 A.V.C. decoupling) has a value of 200,000 and not 250,000 ohms. Similarly R13 is likewise 200,000 ohms instead of the nominal value.

The somewhat unusual trimmer arrangement should be noted in which T1 is located on the condenser gang and is therefore in operation on all ranges. T2, the medium-wave input trimmer, will be found supported in the wiring beneath the chassis and is therefore not accessible without removing the chassis.

The three trimmers for the oscillator are acces-

sible from the side of the oscillator coil can. The correct position of these is as shown in the sketch, and not as in the makers' leaflet, which shows two long-wave trimmers.

Wave-change Switches.—The wave-change switch arrangement is a little confusing because, although one wafer has four wipes and provides for four different positions, there are only 12 contacts. Actually, in the gramophone position the various wipes move on to the contact belonging to the next set of contacts.

The change-over from gramophone to radio is provided by the second wafer, which is mounted nearest to the click plate. There are three wipes on this wafer, two of them going to the points shown in the diagram, and the third is connected to the chassis.

It will also be observed that the switch representations in the diagram do not show the various contacts which are actually linked together. For the sake of simplicity only the active contacts are marked on the switch diagrams in the main circuit, these markings showing all the relevant points which might be required for service work.

Alignment Notes

I.F. Circuits.—Connect the signal generator to the grid of V2 and adjust it to 465 kc. Adjust

T9 and T8 for maximum response on an output meter.

Then connect the signal generator to the control grid of V1 and adjust T7 and T6. Work with the smallest possible input and reduce this as the circuits come into line.

Medium Waves.—Connect oscillator to aerial and earth of receiver through a dummy aerial.

Tune the set and oscillator to 250 metres and adjust T4 and then T1 for maximum response.

Tune the set and oscillator to 500 metres and adjust P1 for maximum simultaneously rocking the gang. Repeat operations until no further improvement results.

Long Waves.—Tune the set and oscillator to 1,200 metres and adjust T5 and T2 for maximum output.

Then tune the set and oscillator to 1,900 metres and adjust P2 for maximum, simultaneously rocking the gang.

Repeat the operations until no further improvement results.

Short Waves.—Tune the set and oscillator to 20 metres and adjust T3 for maximum, using the peak obtained with the trimmer nearest its minimum position.

The aerial trimmer T1 should not be moved, and there is no padding operation as the padder is fixed.