

# 'TRADER' SERVICE SHEETS

## AERODYNE 'BLUEBIRD' MODEL A FOR A.C. MAINS

**A** DROITWICH filter is fitted in the Aerodyne "Bluebird" receiver, and provision is made for a gramophone pick-up and an extension speaker. The circuit consists of a variable-mu H.F. pentode, a triode detector and a pentode output valve. Volume and reaction controls are fitted.

Model A, with which we deal, is for A.C. mains of 200-250 V, 50 cycles. There is also an A.C./D.C. type (Model B).

### CIRCUIT DESCRIPTION

Two alternative aerial connections (A1 via series condenser C2 and Droitwich wave-trap L1, C3, C17, and A2 via series condenser C1) to coupling coils L2, L3. Single tuned circuit L4, L5, C18 precedes first valve which is a variable-mu pentode (V1, Mullard metallised VP4B) operating as H.F. amplifier. Gain control by variable resistance R3 which varies G.B. applied.

Tuned-anode coupling by L7, L8, C20 to triode detector (V2, Mullard metallised 354V) operating on grid leak system with C7 and R8.

Reaction is applied from anode by coil L6 and controlled by variable condenser C22. Provision for connection of gramophone pick-up in grid circuit. H.F. filtering in anode circuit by choke L9 and by-passes C9, C10.

Resistance-capacity coupling by R8, C11, and R10 to output pentode (V3, Mullard Pen4VB). Fixed tone correction in anode circuit by condenser C12. Provision for connection of low impedance external speaker across secondary of internal speaker transformer T1.

H.T. current is supplied by I.H.C. full-wave rectifying valve (V4, Micro-mesh or Brimar R2 or R3). Smoothing by speaker field winding L12 and electrolytic condensers C14, C15. Mains aerial connection by C16.

### COMPONENTS AND VALUES

Condensers		Values (μF)
C1	Aerial series condensers	0.0001
C2		0.0005
C3	Droitwich wave-trap tuning	0.003
C4	V1 S.G. by-pass	0.1
C5	V1 cathode by-pass	0.1
C6*	V1 anode decoupling	1.0
C7	V2 grid condenser	0.00005
C8	V2 anode decoupling	1.0
C9	V2 anode H.F. by-passes	0.0005
C10		0.0005
C11	L.F. coupling to V3	0.01
C12	Tone corrector	0.01
C13*	V3 cathode by-pass	25.0
C14*	H.T. smoothing	8.0
C15*		8.0
C16	Mains aerial coupling	0.0002
C17†	Droitwich wave-trap tuning	0.002
C18†	Aerial circuit tuning	0.0005
C19†	Aerial circuit trimmer	—
C20†	V1 anode circuit tuning	0.0005
C21†	V1 anode circuit trimmer	—
C22†	Reaction control	0.0003

\* Electrolytic † Variable ‡ Pre-set

Resistances		Values (ohms)
R1	V1 S.G. H.T. potential divider	15,000
R2		20,000
R3	V1 gain control	8,000
R4	V1 fixed G.B. resistance	100
R5	V1 anode decoupling	3,000
R6	V2 grid leak	1,000,000
R7	V2 anode decoupling	20,000
R8	V2 anode load	50,000
R9	V3 grid H.F. stopper	50,000
R10	V3 grid resistance	500,000
R11	V3 G.B. resistance	140

Other Components		Values (ohms)
L1	Droitwich wave-trap coil	2.2
L2	Aerial coupling coils	0.75
L3		14.25
L4	Aerial tuning coils	3.5
L5		13.0
L6	Reaction coil	6.5
L7	V1 anode tuning coils	3.5
L8		14.5
L9	V2 anode H.F. choke	200.0
L10	Speaker speech coil	1.75
L11	Hum neutralising coil	0.05
L12	Speaker field coil	1,500.0
T1	Speaker input trans.	Pri. 750.0
		Sec. 0.3
T2	Mains trans.	Pri. total 26.0
		Heater sec. 0.05
		Rect. heat. sec. 0.05
S1-S3	Waveband switches	440.0
S4	Mains switch, ganged R3	—

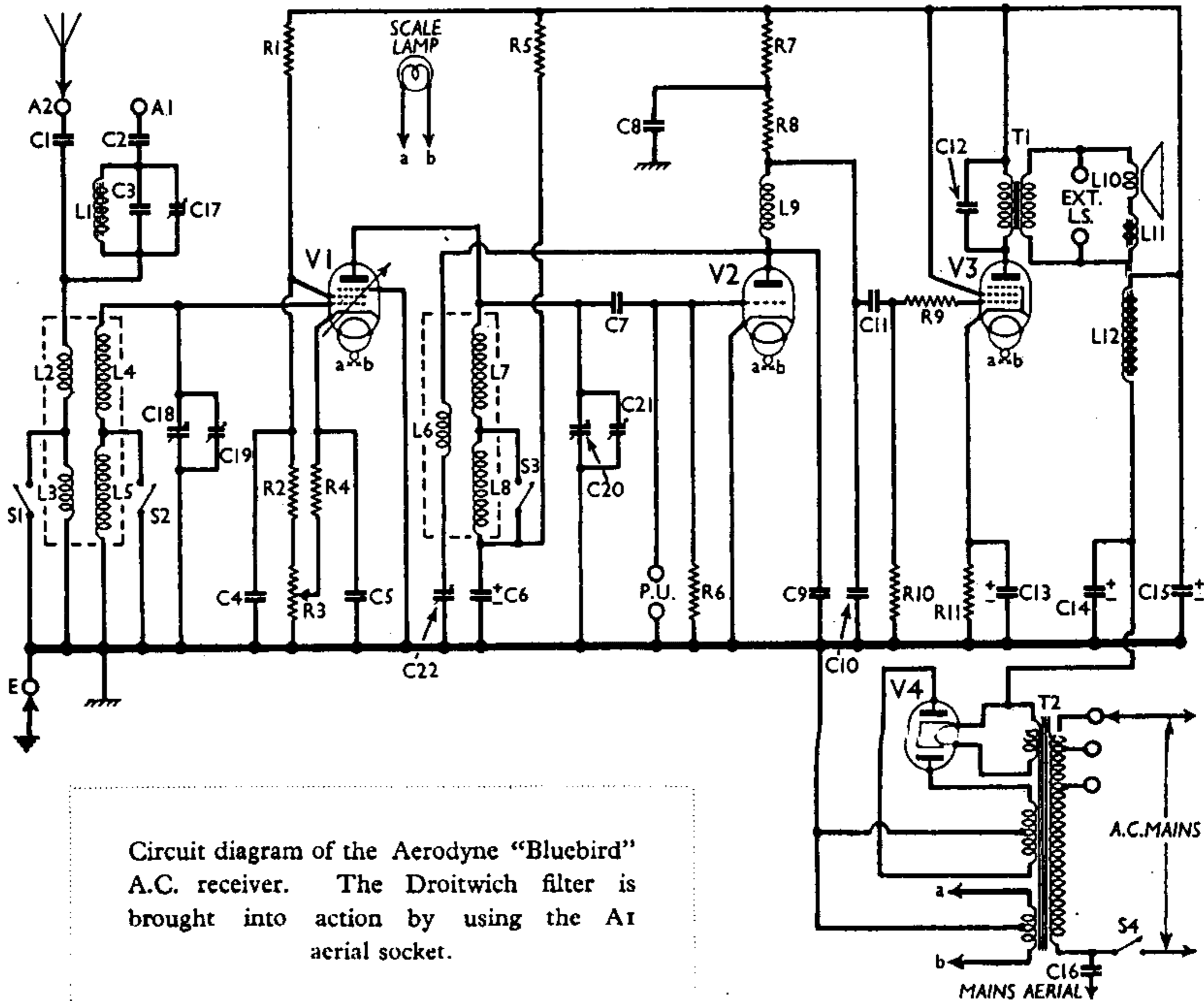

Circuit diagram of the Aerodyne "Bluebird" A.C. receiver. The Droitwich filter is brought into action by using the A1 aerial socket.



**DISMANTLING THE SET**

**Removing Chassis.**—To remove the chassis, remove the back (seven round-head wood screws), four control knobs (pull off), the two round-head wood screws holding the tuning scale to the cabinet front, and the three bolts (with washers) holding the chassis to the cabinet bottom. The chassis can now be withdrawn to the extent of the speaker leads, which is sufficient for normal purposes.

To remove the chassis entirely, unsolder the leads from the speaker terminal panel. When replacing, connect the leads as follows, numbering them from left to right, with the transformer pointing to the bottom right-hand corner of the cabinet: 1 and 2 joined together, red; 3, blue; 4, black.

**Removing Speaker.**—If it is necessary to remove the speaker, slacken the four clamps holding it to the sub-baffle and remove the round-head wood screw (with washer).

**VALVE ANALYSIS**

Readings of valve voltages and currents given in the table below were taken with the receiver operating on 220V A.C. mains, with the transformer on the 230 V tap. The volume control was at maximum, while reaction was at minimum, and there was no signal input. Voltages were measured on the 1,200 V scale of an Avometer, with chassis as negative.

Valve	Anode Volts	Anode Current (mA)	Screen Volts	Screen Current (mA)
V1 VP4B	210	7.4	135	2.7
V2 354V	85	2.8	—	—
V3 Pen4VB	210	30.0	230	3.4
V4 R3	265†	—	—	—

†Each anode, A.C.

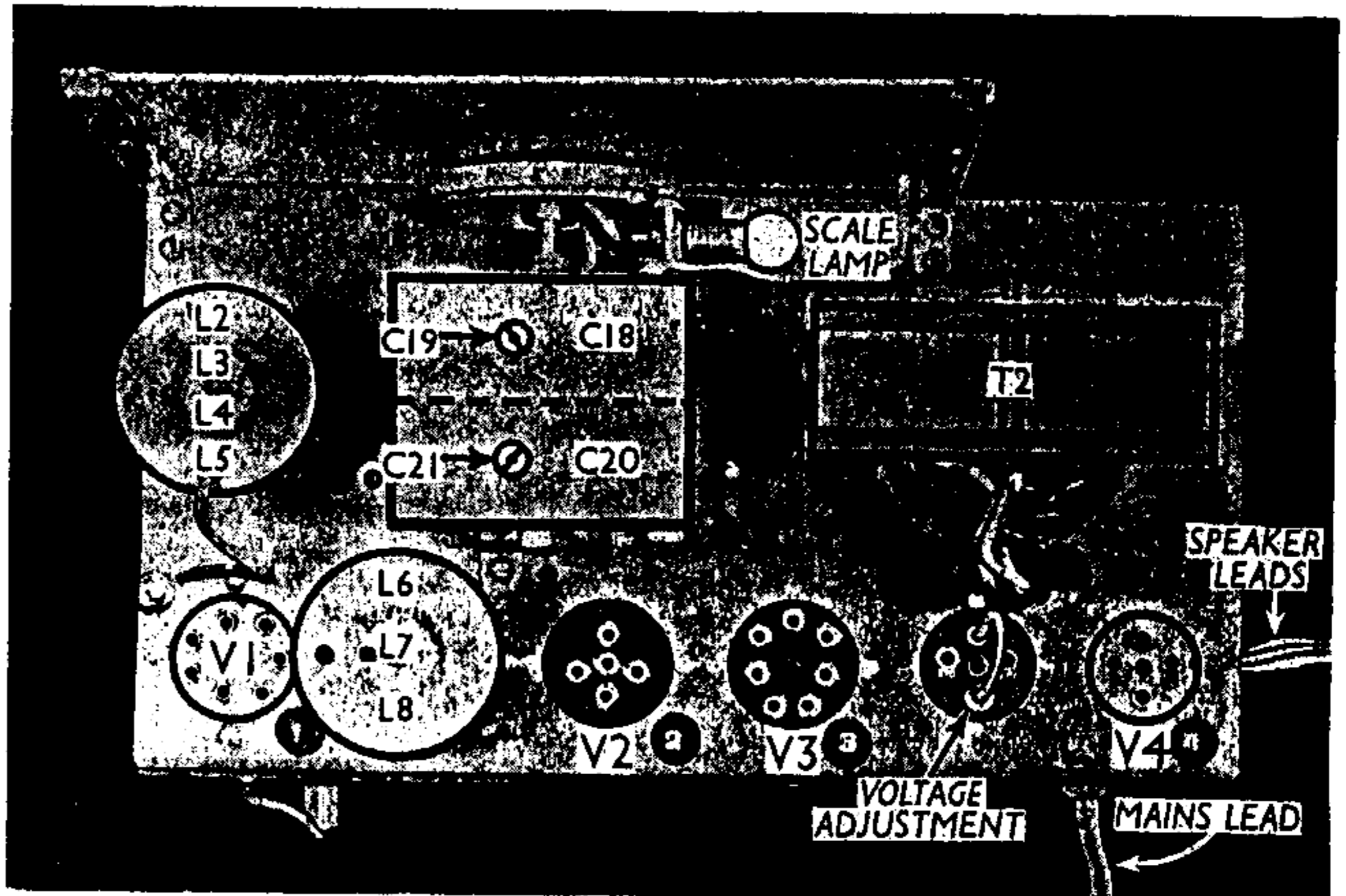

Plan view of the chassis. A valve-holder is used to provide sockets for mains voltage adjustment.

**GENERAL NOTES**

**Switches.**—S1-S3 are the waveband switches, in a single unit, and they are all closed on the M.W. band and open on the L.W. band. Note that S1 and S2 each have one common contact.

S4 is the Q.M.B. mains switch, ganged with the volume control R3.

**Coils.** L1 is the Droitwich wave-trap coil, mounted beneath the chassis. L2-L8 are in two screened units on the chassis deck, and L9 is an H.F. choke, beneath the chassis.

**Scale Lamp.**—This is an Osram M.E.S. type, rated at 6.2 V, 0.3 A.

**External Speaker.**—Two sockets for a low resistance external speaker are provided on a paxolin strip at the base of the speaker transformer. The resistance

of the speaker should be about 2 O.

**Condensers C4, C8, C10.**—These are all hidden beneath the paxolin component panel in the middle of the underside of the chassis. C4 is a tubular type, and C10 a flat mica type, mounted beneath the paxolin panel, while C8 is a 1μF paper type secured to the chassis itself. The positions of these condensers are indicated in our under-chassis view by dotted lines.

**Condensers C14, C15.**—These are two 8μF dry electrolytics in one unit beneath the chassis. There is a common negative (black) lead, and two positives (red). The red lead going to a heater socket of the V4 valve-holder is the positive of C14.

**Condenser C17.**—This tunes the Droitwich filter, and is adjustable through a hole in the side of the chassis.

Under-chassis view. C4, C8 and C10 are beneath the component panel in the centre. C17 is adjusted through a hole in the side of the chassis.

